

# Sustainability and ESG Data Analytics

## Generative AI for ESG Rating and Reporting Generation

1131ESGDA09

MBA, IM, NTPU (M5265) (Fall 2024)

Wed 2, 3, 4 (9:10-12:00) (B3F17)



<https://meet.google.com/miy-fbif-max>

aws  
educate | Cloud  
Ambassador  
2020 Cohort

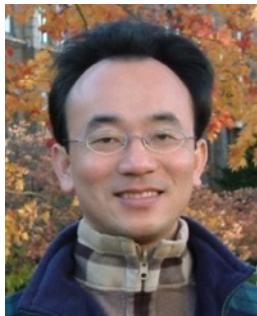

**Min-Yuh Day, Ph.D.**  
**Professor**

**Institute of Information Management, National Taipei University**

<https://web.ntpu.edu.tw/~myday>



# Syllabus

**Week Date Subject/Topics**

**1 2024/09/11 Introduction Sustainability and ESG Data Analytics**

**2 2024/09/18 Environmental, Social, and Governance (ESG) in  
Net-Zero Digital Transformation**

**3 2024/09/25 Data Science for Sustainability and ESG**

**4 2024/10/02 (Class Canceled due to Typhoon)**

**5 2024/10/09 (Self-Learning) Web 3.0 and Big Data Analysis in Fintech,  
Green and Sustainable Finance**

**6 2024/10/16 Case Study on Sustainability and ESG Data Analytics I**

# Syllabus

<b>Week</b>	<b>Date</b>	<b>Subject/Topics</b>
<b>7</b>	<b>2024/10/23</b>	<b>(Self-Learning) Task Force on Climate-Related Financial Disclosures (TCFD) and En-Roads Interactive; ESG Data Gathering, Analysis, and Visualization</b>
<b>8</b>	<b>2024/10/30</b>	<b>(Self-Learning)</b>
<b>9</b>	<b>2024/11/06</b>	<b>Self-Learning</b>
<b>10</b>	<b>2024/11/13</b>	<b>Midterm Project Report</b>
<b>11</b>	<b>2024/11/20</b>	<b>ESG Data Reporting; Corporate Sustainability Reports; ESG Data Verification</b>
<b>12</b>	<b>2024/11/27</b>	<b>Case Study on Sustainability and ESG Data Analytics II</b>

# Syllabus

**Week Date Subject/Topics**

**13 2024/12/04 Artificial Intelligence of things (AIoT) in  
ESG and Sustainability Applications**

**14 2024/12/11 Generative AI for ESG Rating and Reporting Generation**

**15 2024/12/18 Final Project Report I**

**16 2024/12/25 Final Project Report II**

# **Generative AI for ESG Rating and Reporting Generation**

# Outline

- **Generative AI**
- **ESG Rating**
- **ESG Reporting Generation**

**Sherry Madera (2024),  
Navigating Sustainability Data: How Organizations can use ESG  
Data to Secure Their Future, Kogan Page**

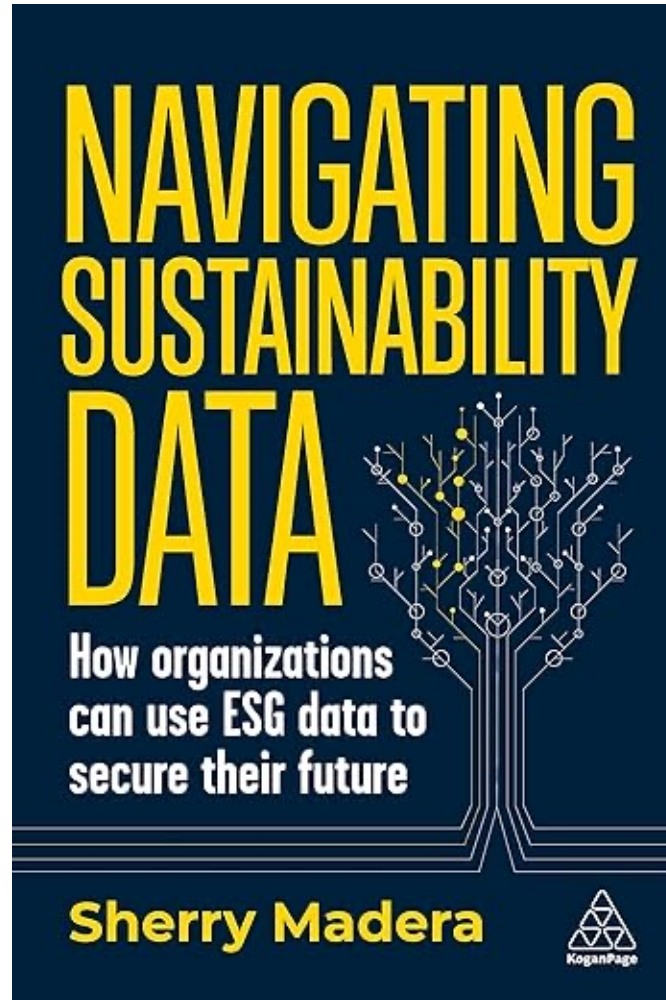

# Generative AI-Driven ESG Report Generation Technology

Industrial Technology Research Institute (ITRI),  
Fintech and Green Finance Center (FGFC, NTPU),  
NTPU-113A513E01, 2024/03/01~2024/12/31

# Generative AI

## Powering

# Digital Sustainability

## Transformation

# Generative AI (Gen AI) AI Generated Content (AIGC)

# Generative AI (Gen AI)

## AI Generated Content (AIGC)

### Unimodal

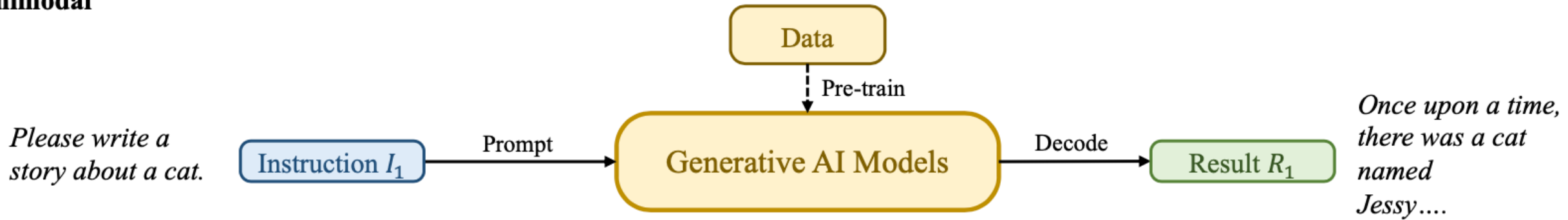

### Multimodal

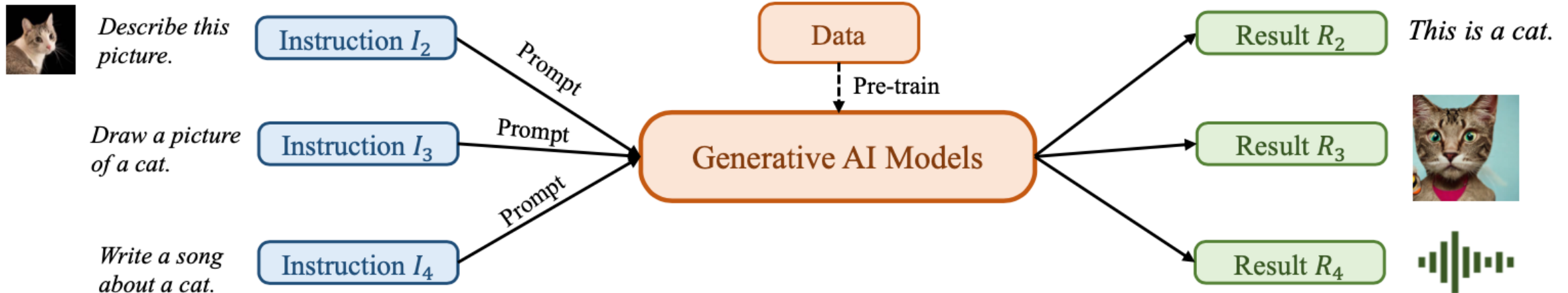

# AI, ML, DL, Generative AI

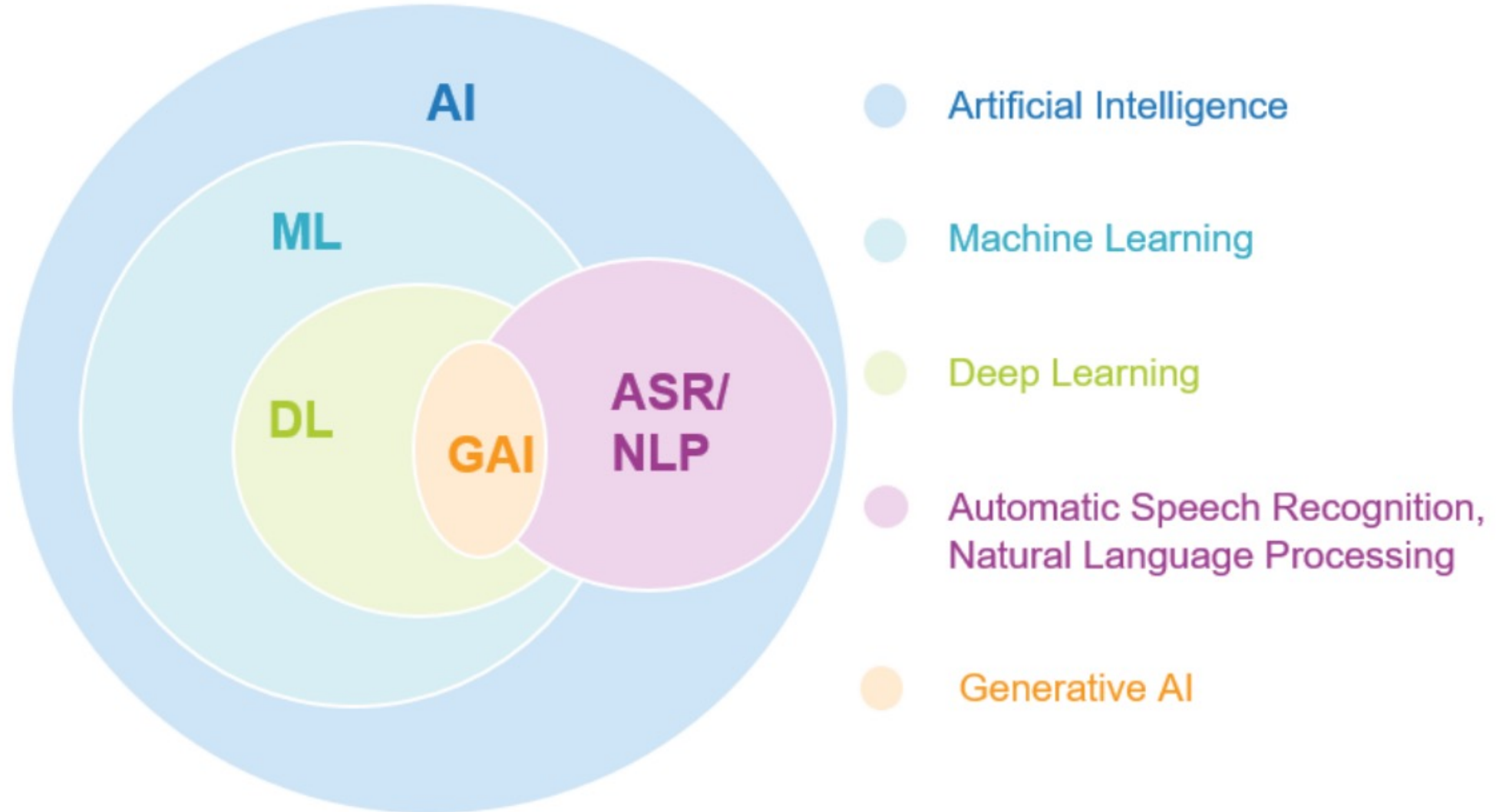

# Comparison of Generative AI and Traditional AI

Feature	Generative AI	Traditional AI
Output type	New content	Classification/Prediction
Creativity	High	Low
Interactivity	Usually more natural	Limited

# Generative AI

- **Generative AI: The Art of Creation**
- **Definition: AI systems capable of creating new content**
- **Characteristics: Creativity, interactivity**

# Generative AI and Large Language Models (LLMs): Popular Generative AI Applications

# Generative AI

# Large Language Models

# (LLMs)

# Foundation Models

# NVIDIA Developer Program

<https://developer.nvidia.com/join-nvidia-developer-program>

## NVIDIA

## Deep Learning Institute (DLI)

<https://learn.nvidia.com/>

# Join the NVIDIA Developer Program

take one of the  
complimentary  
technical self-  
paced courses  
(worth up to \$90)

8 hours

## Getting Started With Deep Learning

Explore the fundamentals of deep learning by training neural networks and using results to improve performance and capabilities.

2 hours

## Modeling Time-Series Data With Recurrent Neural Networks in Keras

Explore how to classify and forecast time-series data using recurrent neural networks (RNNs), such as modeling a patient's health over time.

4 hours

## Deploying a Model for Inference at Production Scale

Learn how to deploy your own machine learning models on a GPU server.

8 hours

## Building Real-Time Video AI Applications

Gain the knowledge and skills needed to enable the real-time transformation of raw video data from widely deployed camera sensors into deep learning-based insights.

2 hours

## Introduction to Graph Neural Networks

Learn the basic concepts, models, and applications of graph neural networks.

4 hours

## Introduction to Physics-Informed Machine Learning With Modulus

Learn the various building blocks of NVIDIA Modulus, which turbocharges use cases by building physics-based deep learning models that are 100,000X faster than traditional methods and offers high-fidelity simulation results.

2 hours

## Get Started With Highly Accurate Custom ASR for Speech AI

Learn to build, train, fine-tune, and deploy a GPU-accelerated automatic speech recognition (ASR) service with NVIDIA® Riva that includes customized features.

2 hours

## Integrating Sensors With NVIDIA DRIVE

Find out how to integrate automotive sensors into your applications using NVIDIA DRIVE®.

# NVIDIA Deep Learning Institute (DLI)

Self-Paced Course

**Generative AI Explained**

Free  
2 hours

Self-Paced Course

**Getting Started With Deep Learning**

Certificate available  
\$90  
8 hours

Instructor-Led Workshop

**Fundamentals of Deep Learning**

Certificate available  
\$500  
8 hours

Self-Paced Course

**Introduction to Transformer-Based Natural Language Processing**

Certificate available  
\$30  
6 hours

Self-Paced Course

**Building RAG Agents With LLMs**

Certificate available  
Free  
8 hours

Instructor-Led Workshop

**Building RAG Agents With LLMs**

Certificate available  
\$500  
8 hours

Self-Paced Course

**Generative AI with Diffusion Models**

Certificate available  
\$90  
8 hours

Instructor-Led Workshop

**Generative AI with Diffusion Models**

Certificate available  
\$500  
8 hours

## What do you want to learn today?

### Filters

Level +

Format +

Topics -

- Deep Learning
- Accelerated Computing
- Generative AI/LLM
- Graphics and Simulation
- OpenUSD
- Data Science
- NIMS
- NIM
- RAPIDS

Free / Paid +

Language +



Sort by: -- ▾

Showing 19 results

**Generative AI** x

# Generative AI

## All Courses

<p>Self-paced</p> <p><b>Generative AI Explained</b></p> <p>Free 02:00</p>	<p>Self-paced</p> <p><b>Generative AI with Diffusion Models</b></p> <p>\$90 08:00</p>	<p>Instructor-Led</p> <p><b>Generative AI with Diffusion Models</b></p> <p>08:00</p>
<p>Self-paced</p> <p><b>Augment your LLM Using</b></p>	<p>Self-paced</p> <p><b>Introduction to Transformer-</b></p>	<p>Instructor-Led</p> <p><b>Rapid Application</b></p>

# Generative AI Explained

Self-paced Course

## Generative AI Explained

In this no-coding course, learn Generative AI concepts and applications, as well as the challenges and opportunities in this exciting field.

[About Course](#)[Objectives](#)[Topics Covered](#)[Course Outline](#)[Stay Informed](#)[Contact Us](#)[Continue Learning](#)

## About this Course

Generative AI describes technologies that are used to generate new content based on a variety of inputs. In recent time, Generative AI involves the use of neural networks to identify patterns and structures within existing data to generate new content. In this course, you will learn Generative AI concepts, applications, as well as the challenges and opportunities in this exciting field.

## Learning Objectives

Upon completion, you will have a basic understanding of Generative AI and be able to more effectively use the various tools built on this

## Course Details

**Duration:** 02:00**Price:** Free**Level:** Technical - Beginner**Subject:** Generative AI/LLM**Language:** English

[https://learn.nvidia.com/courses/course-detail?course\\_id=course-v1:DLI+S-FX-15+V1](https://learn.nvidia.com/courses/course-detail?course_id=course-v1:DLI+S-FX-15+V1)

# Introduction to Transformer-Based Natural Language Processing

Self-paced Course

## Introduction to Transformer-Based Natural Language Processing

Learn how Transformers are used as the building blocks of modern large language models (LLMs). You'll then use these models for various NLP tasks, including text classification, named-entity recognition (NER), author attribution, and question answering.

[About Course](#)[Objectives](#)[Topics Covered](#)[Course Outline](#)[Stay Informed](#)[Contact Us](#)[Continue Learning](#)

### About this Course

Large Language Models (LLMs), or Transformers, have revolutionized the field of natural language processing (NLP). Driven by recent advancements, applications of NLP and generative AI have exploded in the past decade. With the proliferation of applications like chatbots and intelligent virtual assistants, organizations are infusing their businesses with more interactive human-machine experiences. Understanding how Transformer-based large language models (LLMs) can be used to manipulate, analyze, and generate text-based data is essential. Modern pre-trained LLMs can encapsulate the nuance, context, and sophistication of language, just as humans do. When fine-tuned and deployed correctly, developers can use these LLMs to build powerful NLP applications that provide natural and seamless human-computer interactions within chatbots, AI voice agents, and more. In this course, you'll learn how Transformers are used as the building blocks of modern large language models (LLMs). You'll then use these models for various NLP

### Course Details

**Duration:** 06:00**Price:** \$30**Level:** Technical - Beginner**Subject:** Generative AI/LLM**Language:** English

[https://learn.nvidia.com/courses/course-detail?course\\_id=course-v1:DLI+S-FX-08+V1](https://learn.nvidia.com/courses/course-detail?course_id=course-v1:DLI+S-FX-08+V1)

# Building RAG Agents with LLMs

Deep Learning Institute Find Training Self Paced Courses Instructor-Led Workshops Educator Programs Enterprise Solutions Certification Resources

Self-paced Course

## Building RAG Agents with LLMs

Agents powered by large language models (LLMs) have shown great retrieval capability for using tools, looking at documents, and plan their approaches. This course will show you how to deploy an agent system in practice with the flexibility to scale up your system to meet the demands of users and customers.



About Course Objectives Topics Covered Course Outline Stay Informed Contact Us

Continue Learning

## About this Course

This course is free for a limited time.

The evolution and adoption of large language models (LLMs) have been nothing short of revolutionary, with retrieval-based systems at the forefront of this technological leap. These models are not just tools for automation; they are partners in enhancing productivity, capable of holding informed conversations by interacting with a vast array of tools and documents. This course is designed for those eager to explore the potential of these systems, focusing on practical deployment and the efficient implementation required to manage the considerable demands of both users and deep learning models. As we delve into the intricacies of LLMs, participants will gain insights into advanced orchestration techniques that include internal reasoning, dialog management, and effective tooling strategies.

## Course Details

**Duration:** 08:00

**Price:** Free

**Level:** Technical - Intermediate

**Subject:** Generative AI/LLM

**Language:** English

**Course Prerequisites:**

Introductory deep learning knowledge, with comfort

[https://learn.nvidia.com/courses/course-detail?course\\_id=course-v1:DLI+S-FX-15+V1](https://learn.nvidia.com/courses/course-detail?course_id=course-v1:DLI+S-FX-15+V1)

# Generative AI with Diffusion Models

Self-paced Course

## Generative AI with Diffusion Models

Take a deeper dive into denoising diffusion models, which are a popular choice for text-to-image pipelines, with applications in creative content generation, data augmentation, simulation and planning, anomaly detection, drug discovery, personalized recommendations, and more.



[About Course](#)
[Objectives](#)
[Topics Covered](#)
[Course Outline](#)
[Stay Informed](#)
[Contact Us](#)

[Continue Learning](#)

### About this Course

Thanks to improvements in computing power and scientific theory, generative AI is more accessible than ever before. Generative AI plays a significant role across industries due to its numerous applications, such as creative content generation, data augmentation, simulation and planning, anomaly detection, drug discovery, personalized recommendations, and more. In this course, learners will take a deeper dive into denoising diffusion models, which are a popular choice for text-to-image pipelines.

### Learning Objectives

[https://learn.nvidia.com/courses/course-detail?course\\_id=course-v1:DLI+S-FX-14+V1](https://learn.nvidia.com/courses/course-detail?course_id=course-v1:DLI+S-FX-14+V1)

### Course Details

**Duration:** 08:00

**Price:** \$90

**Subject:** Generative AI/LLM

**Language:** English

**Course Prerequisites:**

A basic understanding of [Deep Learning Concepts](#).

# Join the NVIDIA Developer Program

take one of the complimentary technical self-paced courses (worth up to \$90)

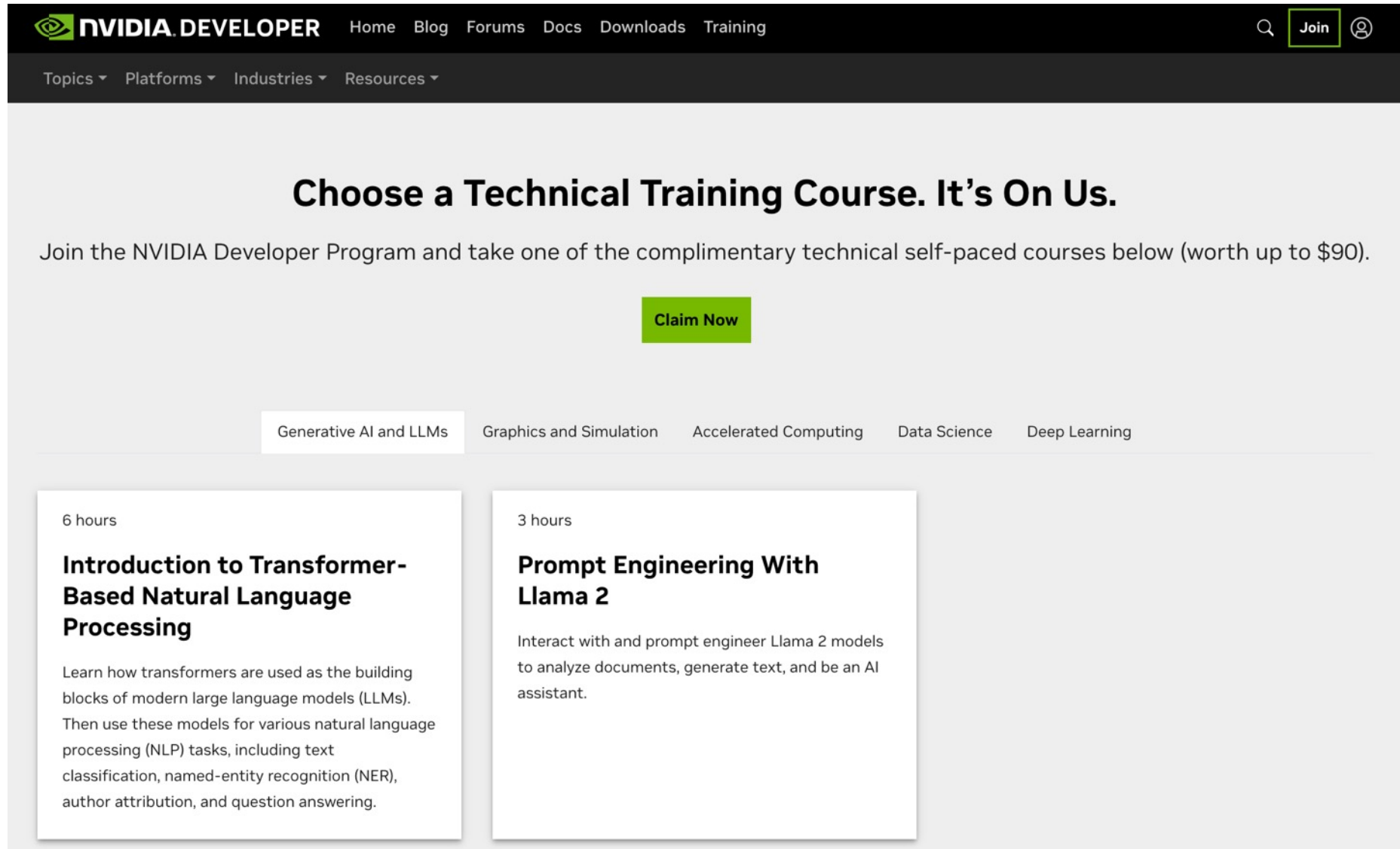

The screenshot shows the NVIDIA Developer Program website. At the top, there is a navigation bar with the NVIDIA logo, the text "NVIDIA DEVELOPER", and links for Home, Blog, Forums, Docs, Downloads, and Training. A search icon and a "Join" button are also present. Below the navigation bar, there are dropdown menus for Topics, Platforms, Industries, and Resources. The main content area features a large heading "Choose a Technical Training Course. It's On Us." followed by a sub-heading "Join the NVIDIA Developer Program and take one of the complimentary technical self-paced courses below (worth up to \$90)." and a prominent green "Claim Now" button. Below this, there are five category tabs: "Generative AI and LLMs" (which is selected), "Graphics and Simulation", "Accelerated Computing", "Data Science", and "Deep Learning". Two course cards are displayed under the "Generative AI and LLMs" category. The first card is titled "Introduction to Transformer-Based Natural Language Processing" and is 6 hours long. The second card is titled "Prompt Engineering With Llama 2" and is 3 hours long. The description for the second course reads: "Interact with and prompt engineer Llama 2 models to analyze documents, generate text, and be an AI assistant."

<https://developer.nvidia.com/join-nvidia-developer-program>

# Transformer Models

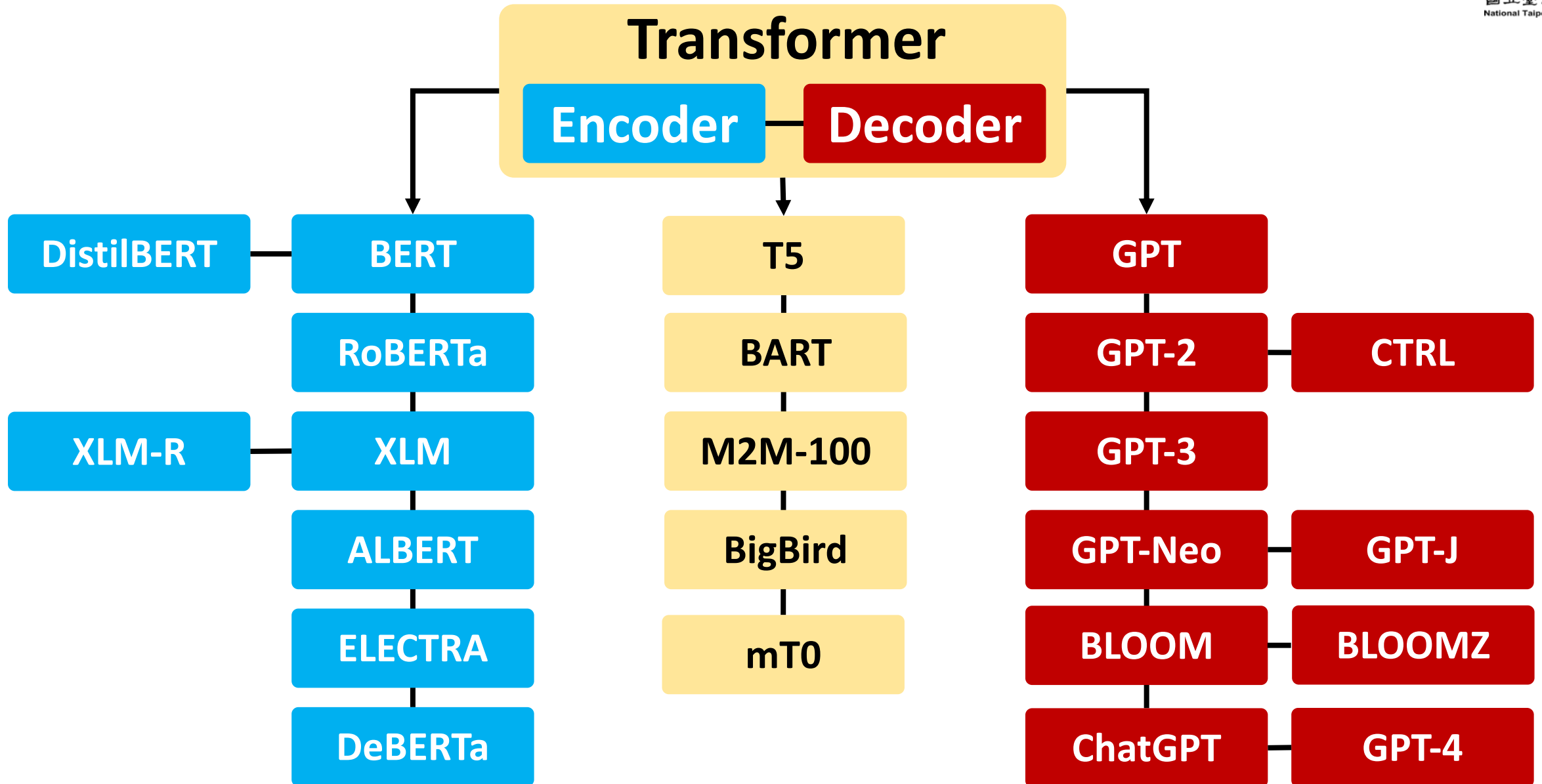

# The Development of LM-based Dialogue Systems

- 1) Early Stage (1966 - 2015)
- 2) The Independent Development of TOD and ODD (2015 - 2019)
- 3) Fusions of Dialogue Systems (2019 - 2022)
- 4) LLM-based DS (2022 - Now)

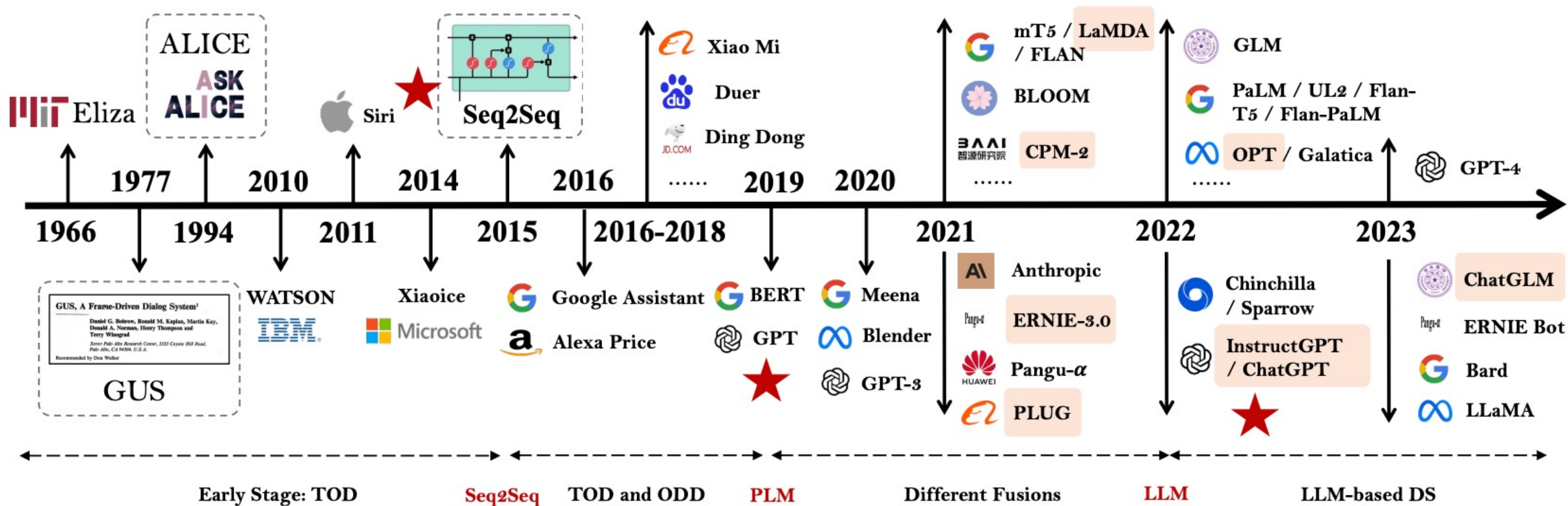

Task-oriented DS (TOD), Open-domain DS (ODD)

# Major GenAI LLMs Research Milestones (2017-2024)

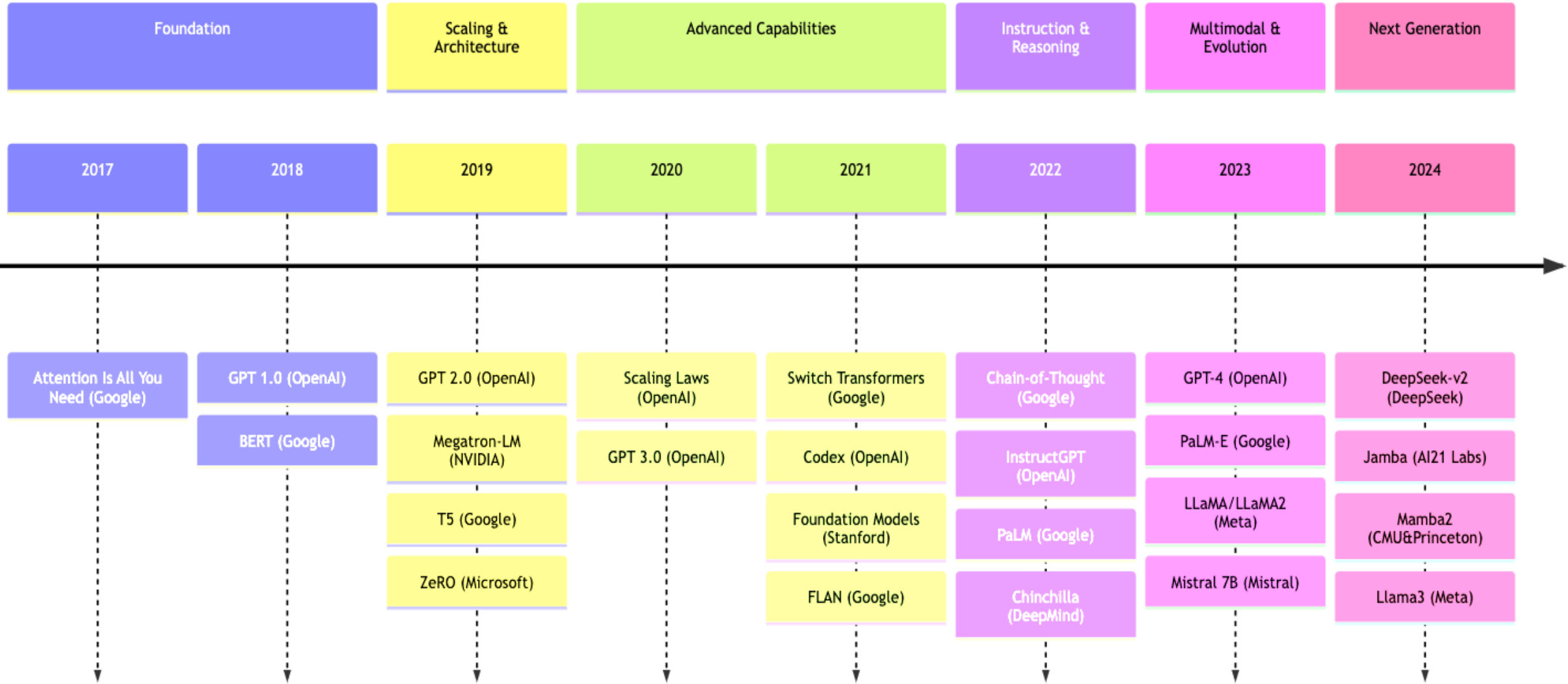

# Multimodal Large Language Models (MLLM)

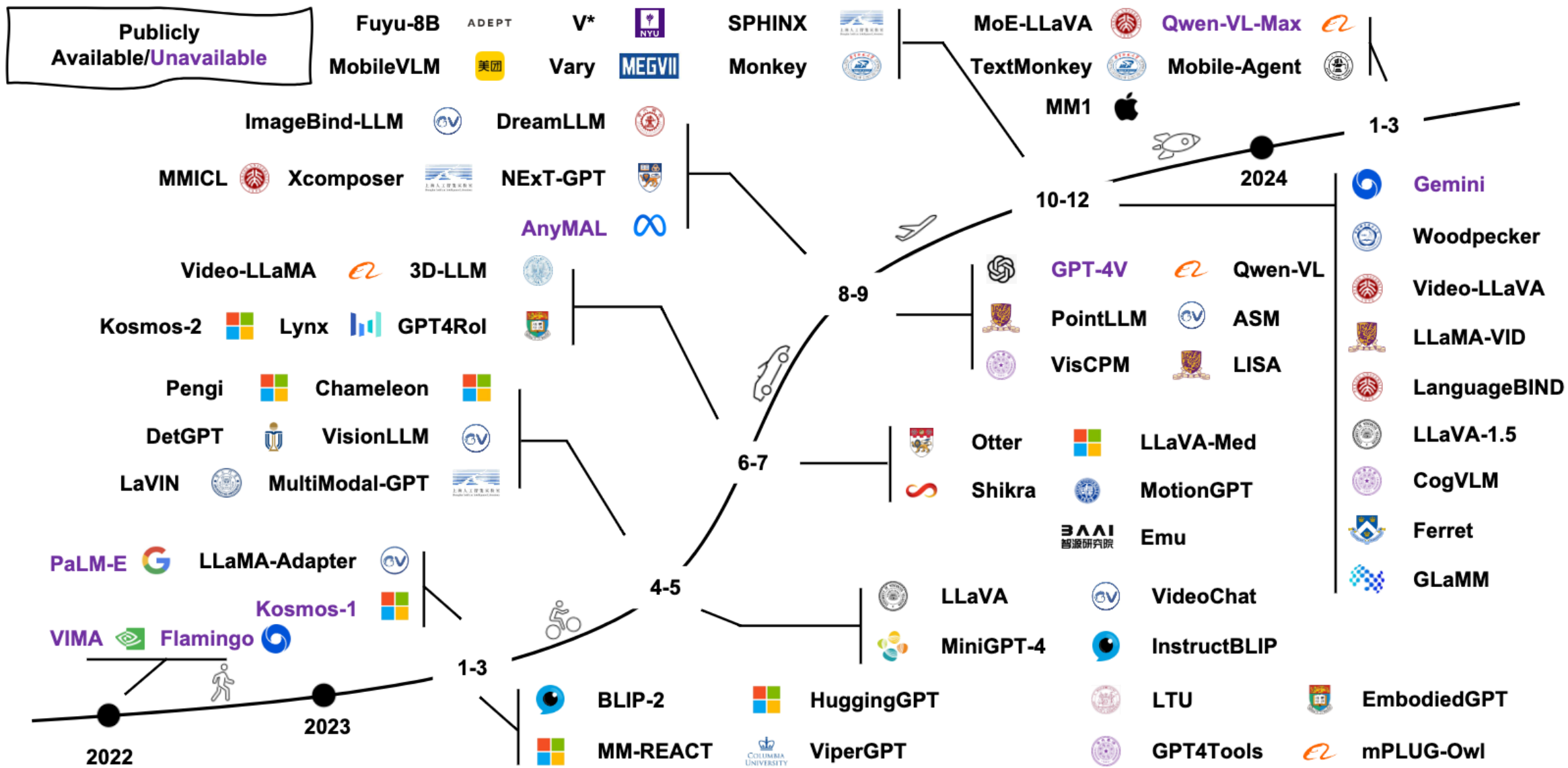

# Multimodal Large Language Models (MLLM)

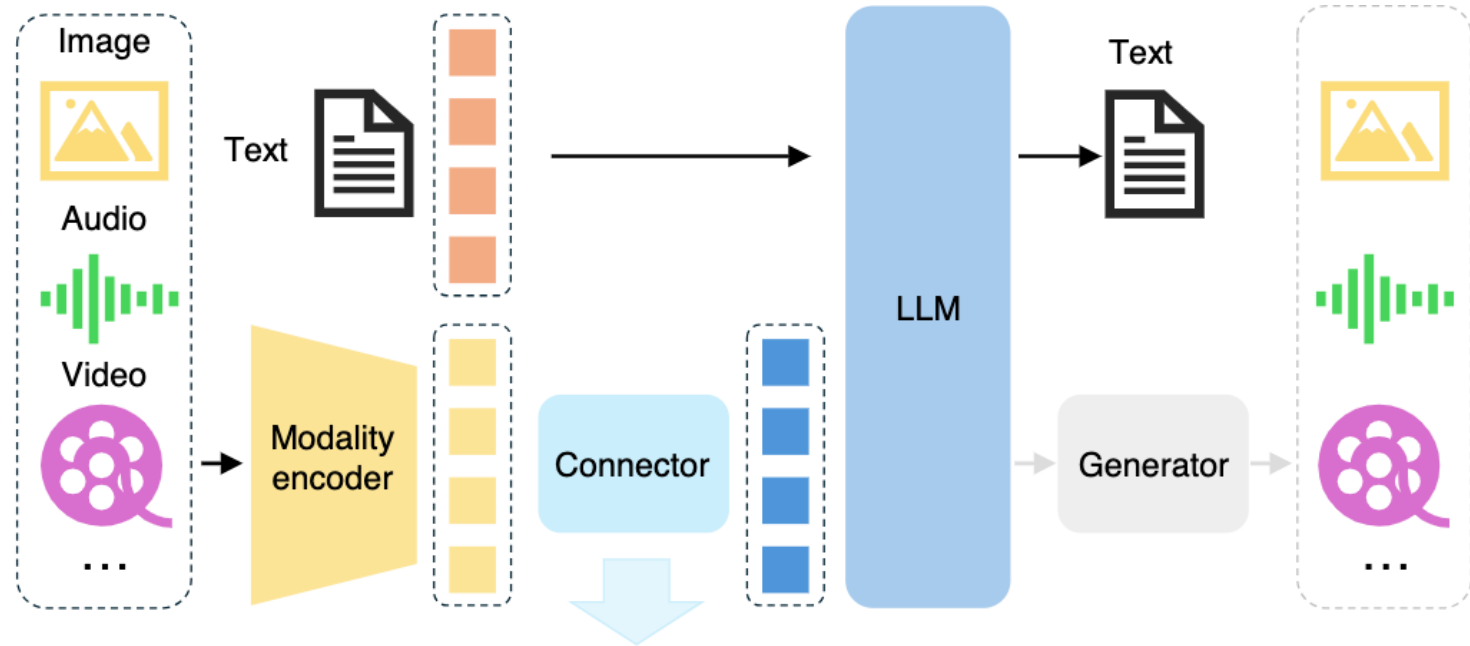

## Multimodal LLM

Three types of connectors:

1. projection-based
2. query-based
3. fusion-based connectors

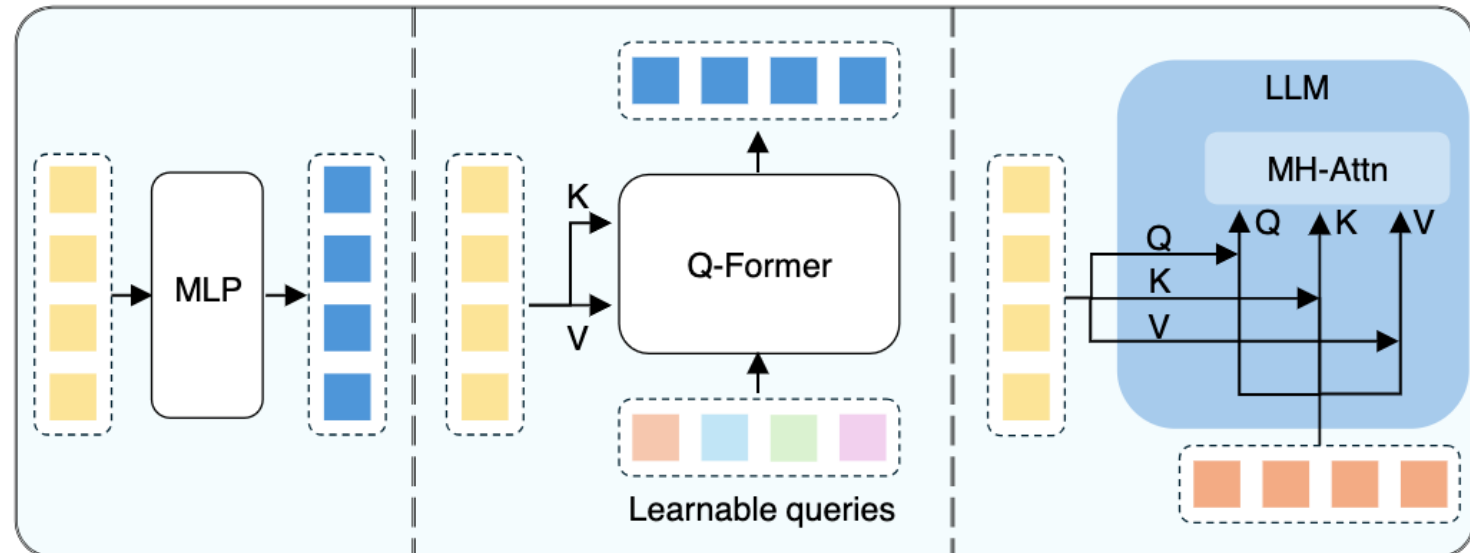

# Multimodal Large Language Model (MLLM) for Vision Question Answering

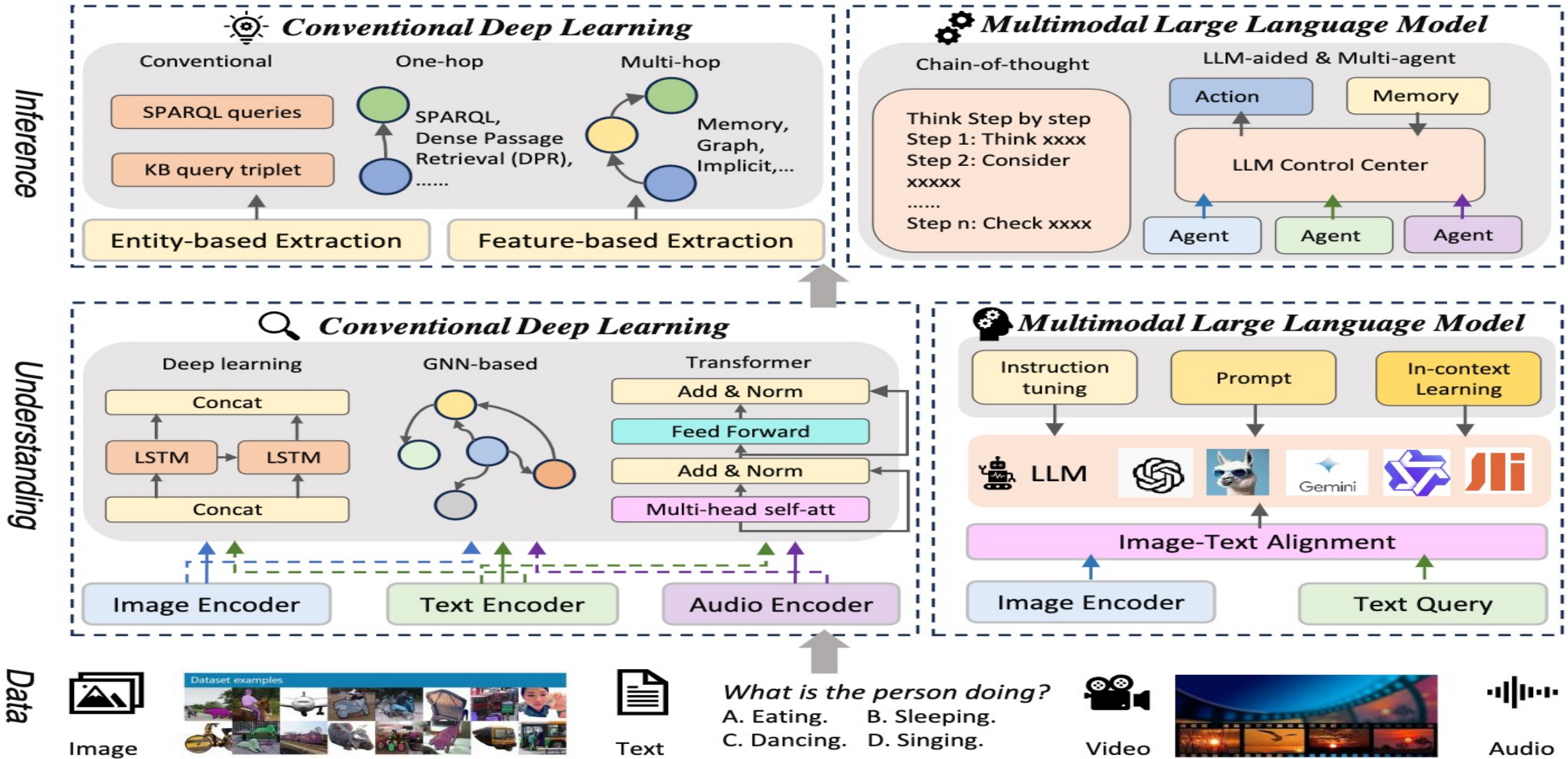

# Multi-task Language Understanding on MMLU

## GPT-4, Claude 3.5 Sonnet

### Massive Multitask Language Understanding (MMLU)

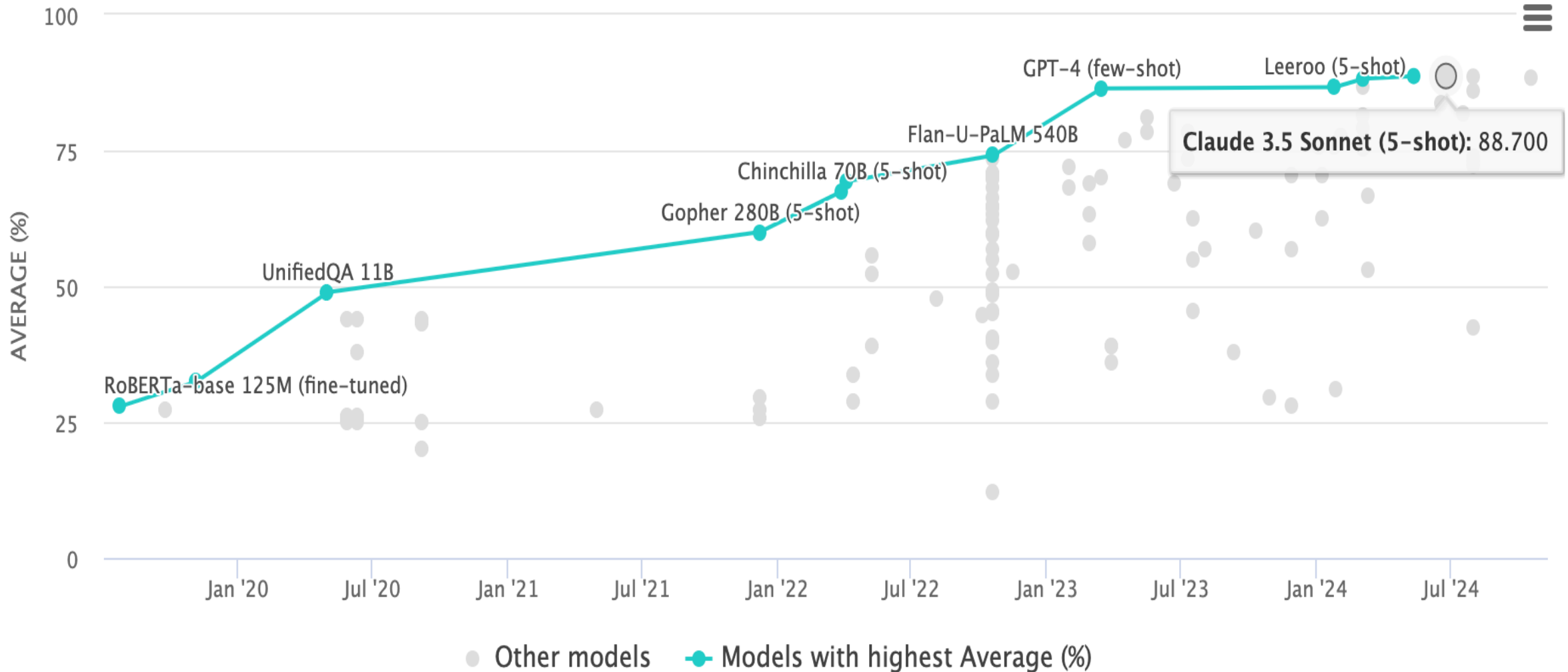

# LLM Capabilities

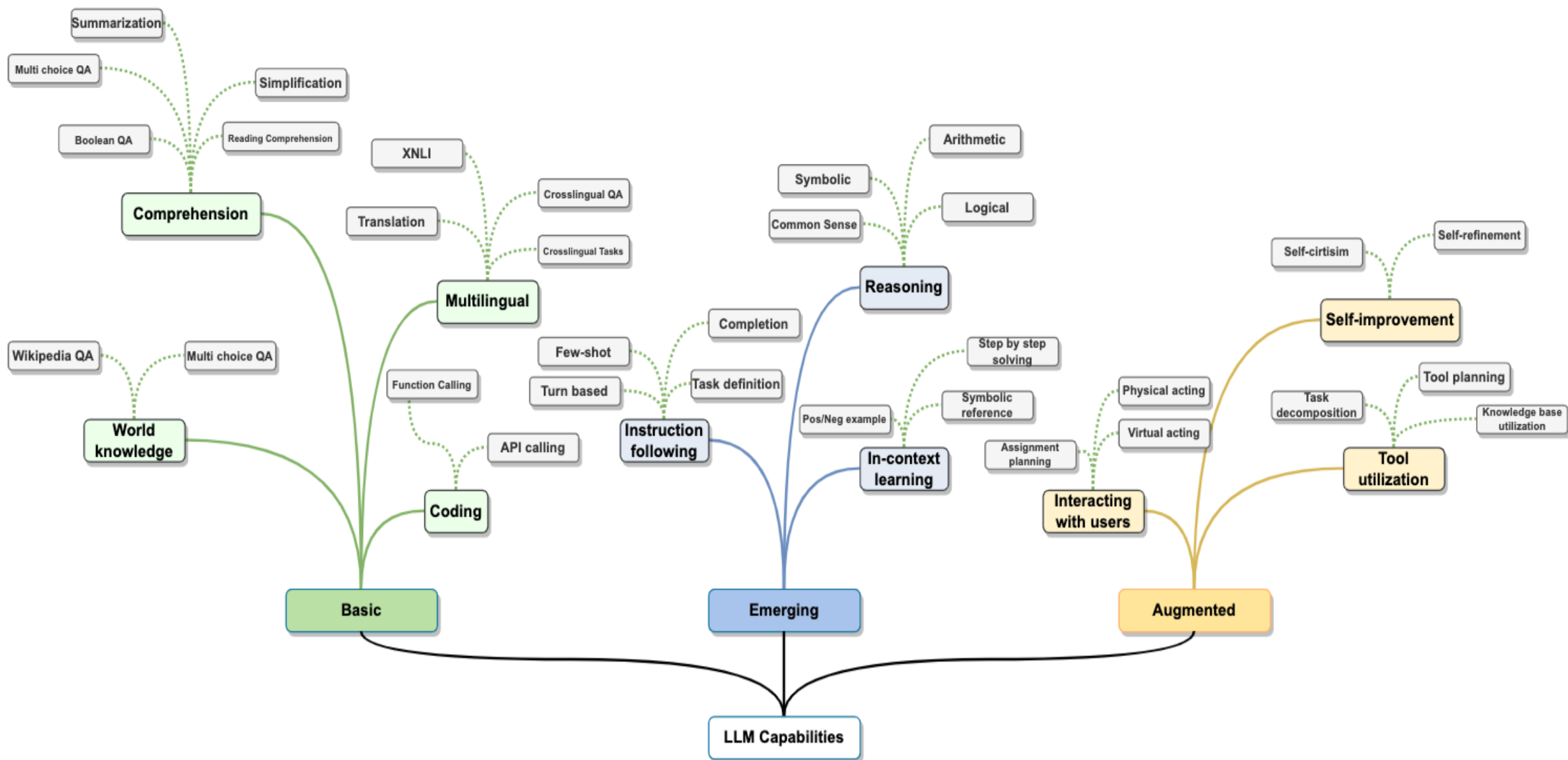

# LLM-powered Multimodal Agents

## Large Multimodal Agents (LMAs)

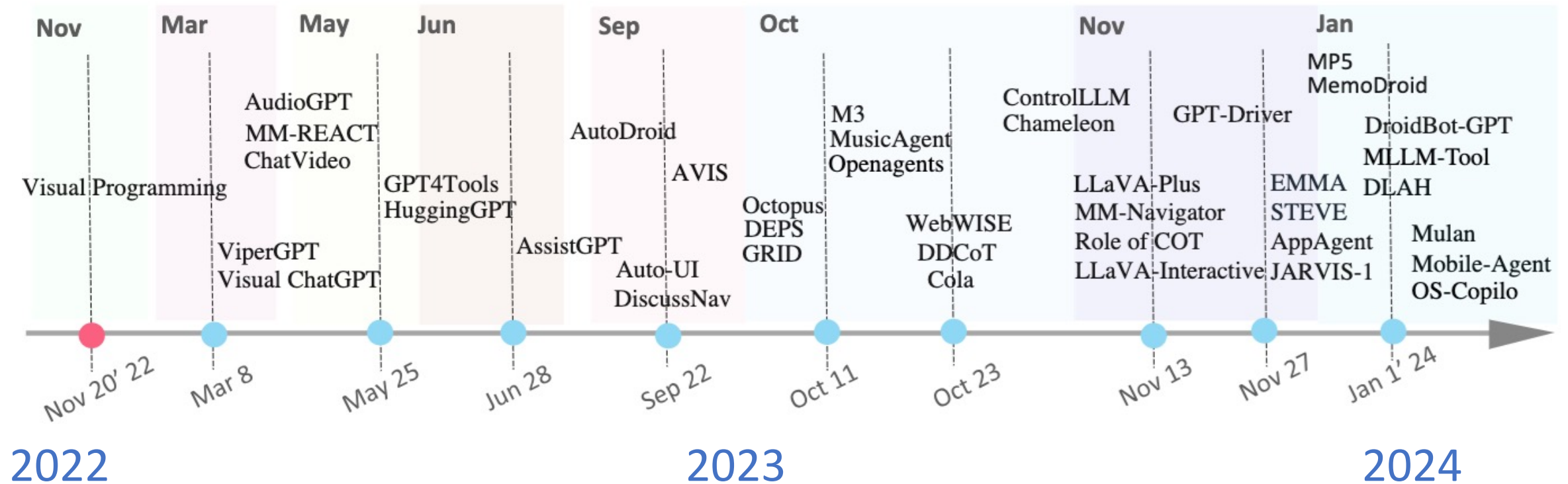

# Four Paradigms in NLP (LM)

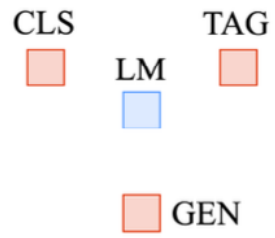
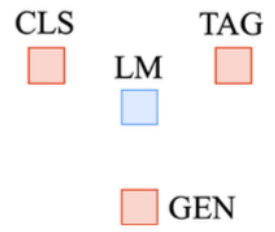
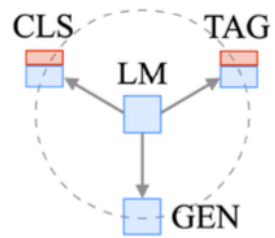
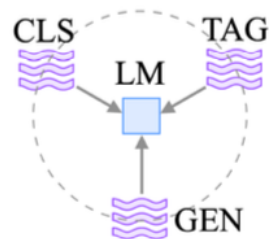
Paradigm	Engineering	Task Relation
a. Fully Supervised Learning (Non-Neural Network)	Feature (e.g. word identity, part-of-speech, sentence length)	
b. Fully Supervised Learning (Neural Network)	Architecture (e.g. convolutional, recurrent, self-attentional)	
<b>Transfer Learning: Pre-training, Fine-Tuning (FT)</b>		
c. Pre-train, Fine-tune	Objective (e.g. masked language modeling, next sentence prediction)	
<b>GAI: Pre-train, Prompt, and Predict (Prompting)</b>		
d. Pre-train, Prompt, Predict	Prompt (e.g. cloze, prefix)	

# Large Language Models (LLM)

## Three typical learning paradigms

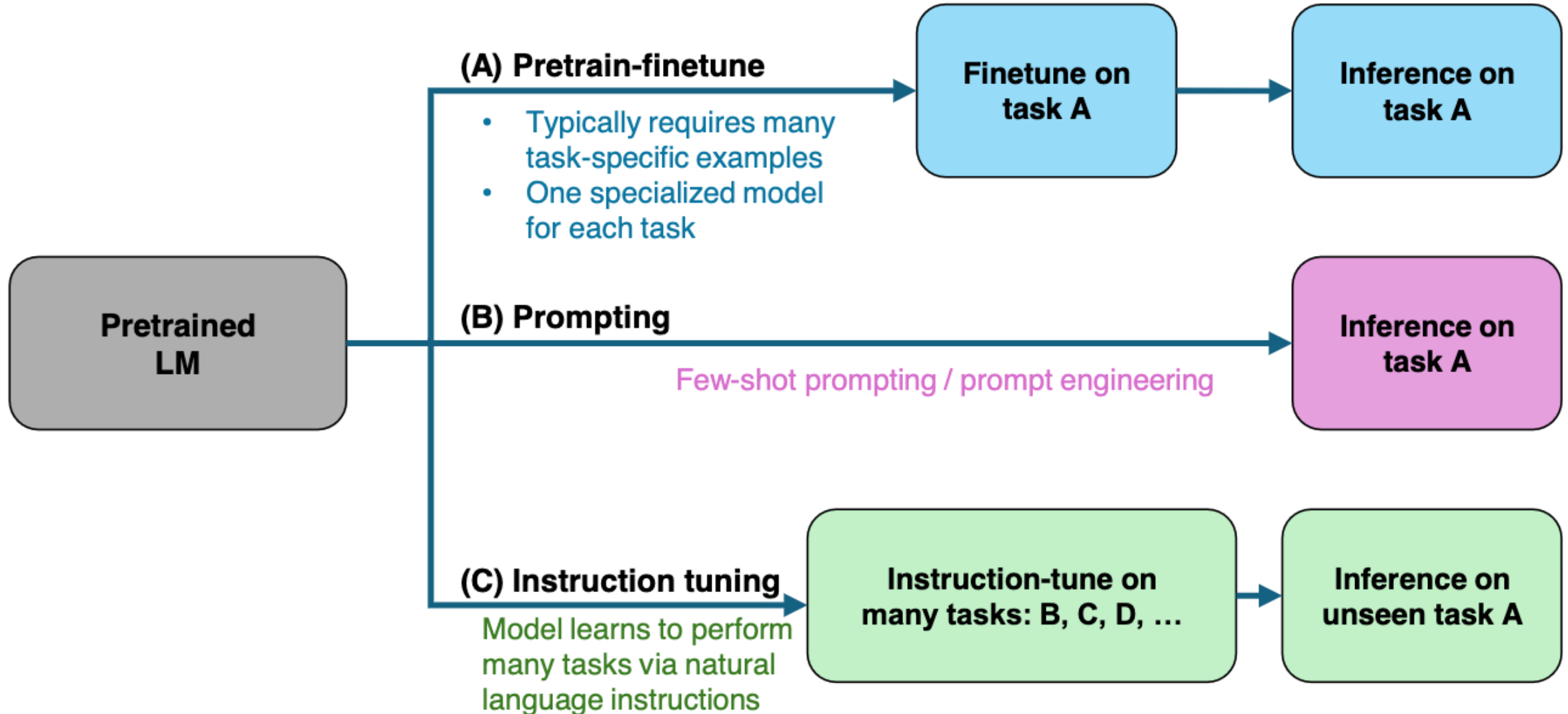

# Popular Generative AI

- **OpenAI ChatGPT (GPT-o1, GPT-4o, GPT-4)**
- **Claude.ai (Claude 3.5)**
- **Google Gemini**
- **Meta Llama 3.3, Llama 3.2 Vision**
- **Mixtral Pixtral (mistral.ai)**
- **Chat.LMSys.org (lmarena.ai)**
- **Perplexity.ai**
- **Stable Diffusion**
- **Video: D-ID, Synthesia**
- **Audio: Speechify**

# LMSYS Chatbot Arena Leaderboard

Rank* (UB)	Rank (StyleCtrl)	Model	Arena Score	95% CI	Votes	Organization	License
1	1	<a href="#">Gemini-Exp-1206</a>	1379	+10/-5	5052	Google	Proprietary
2	1	<a href="#">ChatGPT-4o-latest (2024-11-20)</a>	1366	+4/-5	21929	OpenAI	Proprietary
2	4	<a href="#">Gemini-Exp-1121</a>	1364	+4/-5	15004	Google	Proprietary
4	3	<a href="#">o1-preview</a>	1334	+5/-4	30448	OpenAI	Proprietary
5	7	<a href="#">o1-mini</a>	1307	+4/-3	37176	OpenAI	Proprietary
5	6	<a href="#">Gemini-1.5-Pro-002</a>	1302	+5/-3	32758	Google	Proprietary
7	10	<a href="#">Grok-2-08-13</a>	1289	+3/-3	55616	xAI	Proprietary
7	11	<a href="#">Yi-Lightning</a>	1287	+4/-4	29193	01 AI	Proprietary
7	6	<a href="#">GPT-4o-2024-05-13</a>	1285	+3/-3	116858	OpenAI	Proprietary
7	4	<a href="#">Claude 3.5 Sonnet (20241022)</a>	1283	+3/-3	34846	Anthropic	Proprietary
8	17	<a href="#">Athene-v2-Chat-72B</a>	1278	+6/-6	8700	NexusFlow	NexusFlow
11	16	<a href="#">GLM-4-Plus</a>	1274	+4/-5	28006	Zhipu AI	Proprietary
11	18	<a href="#">GPT-4o-mini-2024-07-18</a>	1273	+3/-3	54539	OpenAI	Proprietary
11	21	<a href="#">Gemini-1.5-Flash-002</a>	1271	+4/-4	26276	Google	Proprietary
11	28	<a href="#">Llama-3.1-Nemotron-70B-Instruct</a>	1269	+6/-6	7676	Nvidia	Llama 3.1

GPT-4o

Claude 3.5

# Claude 3.5 Sonnet state-of-the-art vision

	Claude 3.5 Sonnet (new)	Claude 3.5 Haiku	Claude 3.5 Sonnet	GPT-4o*	GPT-4o mini*	Gemini 1.5 Pro	Gemini 1.5 Flash
Graduate level reasoning <i>GPQA (Diamond)</i>	<b>65.0%</b> 0-shot CoT	<b>41.6%</b> 0-shot CoT	<b>59.4%</b> 0-shot CoT	<b>53.6%</b> 0-shot CoT	<b>40.2%</b> 0-shot CoT	<b>59.1%</b> 0-shot CoT	<b>51.0%</b> 0-shot CoT
Undergraduate level knowledge <i>MMLU Pro</i>	<b>78.0%</b> 0-shot CoT	<b>65.0%</b> 0-shot CoT	<b>75.1%</b> 0-shot CoT	—	—	<b>75.8%</b> 0-shot CoT	<b>67.3%</b> 0-shot CoT
Code <i>HumanEval</i>	<b>93.7%</b> 0-shot	<b>88.1%</b> 0-shot	<b>92.0%</b> 0-shot	<b>90.2%</b> 0-shot	<b>87.2%</b> 0-shot	—	—
Math problem-solving <i>MATH</i>	<b>78.3%</b> 0-shot CoT	<b>69.2%</b> 0-shot CoT	<b>71.1%</b> 0-shot CoT	<b>76.6%</b> 0-shot CoT	<b>70.2%</b> 0-shot CoT	<b>86.5%</b> 4-shot CoT	<b>77.9%</b> 4-shot CoT
High school math competition <i>AIME 2024</i>	<b>16.0%</b> 0-shot CoT	<b>5.3%</b> 0-shot CoT	<b>9.6%</b> 0-shot CoT	<b>9.3%</b> 0-shot CoT	—	—	—
Visual Q/A <i>MMMU</i>	<b>70.4%</b> 0-shot CoT	—	<b>68.3%</b> 0-shot CoT	<b>69.1%</b> 0-shot CoT	<b>59.4%</b> 0-shot CoT	<b>65.9%</b> 0-shot CoT	<b>62.3%</b> 0-shot CoT
Agentic coding <i>SWE-bench Verified</i>	<b>49.0%</b>	<b>40.6%</b>	<b>33.4%</b>	—	—	—	—
Agentic tool use <i>TAU-bench</i>	Retail <b>69.2%</b> Airline <b>46.0%</b>	Retail <b>51.0%</b> Airline <b>22.8%</b>	Retail <b>62.6%</b> Airline <b>36.0%</b>	—	—	—	—

\* Our evaluation tables exclude OpenAI's o1 model family as they depend on extensive pre-response computation time, unlike typical models. This fundamental difference makes performance comparisons difficult.

# Llama 3.2 90B vision LLMs

Modality	Category Benchmark	Llama 3.2 11B	Llama 3.2 90B	Claude 3 – Haiku	GPT-4o-mini
Image	College-level Problems and Mathematical Reasoning MMMU (val, 0-shot CoT, micro avg accuracy)	50.7	60.3	50.2	59.4
	MMMU-Pro, Standard (10 opts, test)	33.0	45.2	27.3	42.3
	MMMU-Pro, Vision (test)	23.7	33.8	20.1	36.5
	MathVista (testmini)	51.5	57.3	46.4	56.7
	Charts and Diagram Understanding ChartQA (test, 0-shot CoT relaxed accuracy)*	83.4	85.5	81.7	—
	AI2 Diagram (test)*	91.1	92.3	86.7	—
	DocVQA (test, ANLS)*	88.4	90.1	88.8	—
	General Visual Question Answering VQAv2 (test)	75.2	78.1	—	—
Text	General MMLU (0-shot, CoT)	73.0	86.0	75.2 (5-shot)	82.0
	Math MATH (0-shot, CoT)	51.9	68.0	38.9	70.2
	Reasoning GPQA (0-shot, CoT)	32.8	46.7	33.3	40.2
	Multilingual MGSM (0-shot, CoT)	68.9	86.9	75.1	87.0

# Llama 3.3 70B instruction-tuned

Category Benchmark	Llama 3.1 70B	Llama 3.3 70B	Amazon Nova Pro	Llama 3.1 405B	Gemini Pro 1.5	GPT-4o	Claude 3.5 Sonnet
General							
MMLU Chat (0-shot, CoT)	86.0	<b>86.0</b>	85.9	<b>88.6</b>	87.1	87.5	<b>88.9</b>
MMLU PRO (5-shot, CoT)	66.4	<b>68.9</b>	-	<b>73.4</b>	76.1	73.8	<b>77.8</b>
Instruction Following							
IFEval	87.5	<b>92.1</b>	<b>92.1</b>	<b>88.6</b>	81.9	84.6	<b>89.3</b>
Code							
HumanEval (0-shot)	80.5	<b>88.4</b>	<b>89.0</b>	<b>89.0</b>	89.0	86.0	<b>93.7</b>
MBPP EvalPlus (base) (0-shot)	86.0	<b>87.6</b>	-	<b>88.6</b>	87.8	83.9	86.8
Math							
MATH (0-shot, CoT)	67.8	<b>77.0</b>	76.6	<b>73.9</b>	<b>82.9</b>	76.9	78.3
Reasoning							
GPQA Diamond (0-shot, CoT)	48.0	<b>50.5</b>	-	<b>49.0</b>	53.5	47.5	<b>65.0</b>
Tool use							
BFCL v2 (0-shot)	77.5	<b>77.3</b>	-	<b>81.1</b>	80.3	74.0	79.3
Long context							
NIH/Multi-needle	97.5	<b>97.5</b>	-	<b>98.1</b>	94.7	-	<b>99.4</b>
Multilingual							
Multilingual MGSM (0-shot)	86.9	<b>91.1</b>	-	<b>91.6</b>	89.6	90.6	<b>92.8</b>
Pricing*							
1M Input tokens (Cheapest among providers)*	\$0.1	<b>\$0.1</b>	\$0.80	<b>\$1.0</b>	\$1.30	2.5\$	\$3.0
1M Output tokens (Cheapest among providers)*	\$0.4	<b>\$0.4</b>	\$3.20	<b>\$1.8</b>	\$5.0	10.0\$	\$15.0

<https://www.llama.com/>

# Mistral Pixtral Large (124B)

## Frontier-class multimodal performance

Model	Mathvista (CoT)	MMMU (CoT)	ChartQA (CoT)	DocVQA (ANLS)	VQAv2 (VQA Match)	AI2D (BBox)	MM MT-Bench	
Open Weights	Pixtral Large (124B)	<b>69.4</b>	64.0	88.1	<b>93.3</b>	<b>80.9</b>	93.8	<b>7.4</b>
	Llama-3.2 90B (measured)	49.1	53.7	70.8	85.7	67.0	-	5.5
	Llama-3.2 90B (reported)	57.3	60.3	85.8	90.1	80.2	92.3	-
Closed	Gemini-1.5 Pro (measured)	<b>67.8</b>	<b>66.3</b>	<b>83.8</b>	<b>92.3</b>	<b>70.6</b>	<b>94.6</b>	<b>6.8</b>
	Gemini-1.5 Pro (reported)	68.1	65.9	-	-	-	-	-
	GPT-4o (measured)	<b>65.4</b>	<b>68.6</b>	<b>85.2</b>	<b>88.5</b>	<b>76.4</b>	<b>93.2</b>	<b>6.7</b>
	GPT-4o (reported)	63.8	69.1	85.7	92.8	-	-	-
	Claude-3.5 Sonnet (measured)	<b>67.1</b>	<b>68.4</b>	<b>89.1</b>	<b>88.6</b>	<b>69.5</b>	<b>76.9</b>	<b>7.3</b>
	Claude-3.5 Sonnet (reported)	70.7	70.4	90.8	94.2	-	95.3	-
Unreleased	Llama-3.1 505B (reported)	-	64.5	85.8	92.6	80.2	94.1	-
	Grok-2 (reported)	69.0	66.1	-	93.6	-	-	-

Specific model versions evaluated: Claude-3.5 Sonnet (new) [Oct 24], Gemini-1.5 Pro (002) [Sep 24], GPT-4o (2024-08-06) [Aug 24]

Source: <https://mistral.ai/news/pixtral-large/>

# Mistral Pixtral 12B

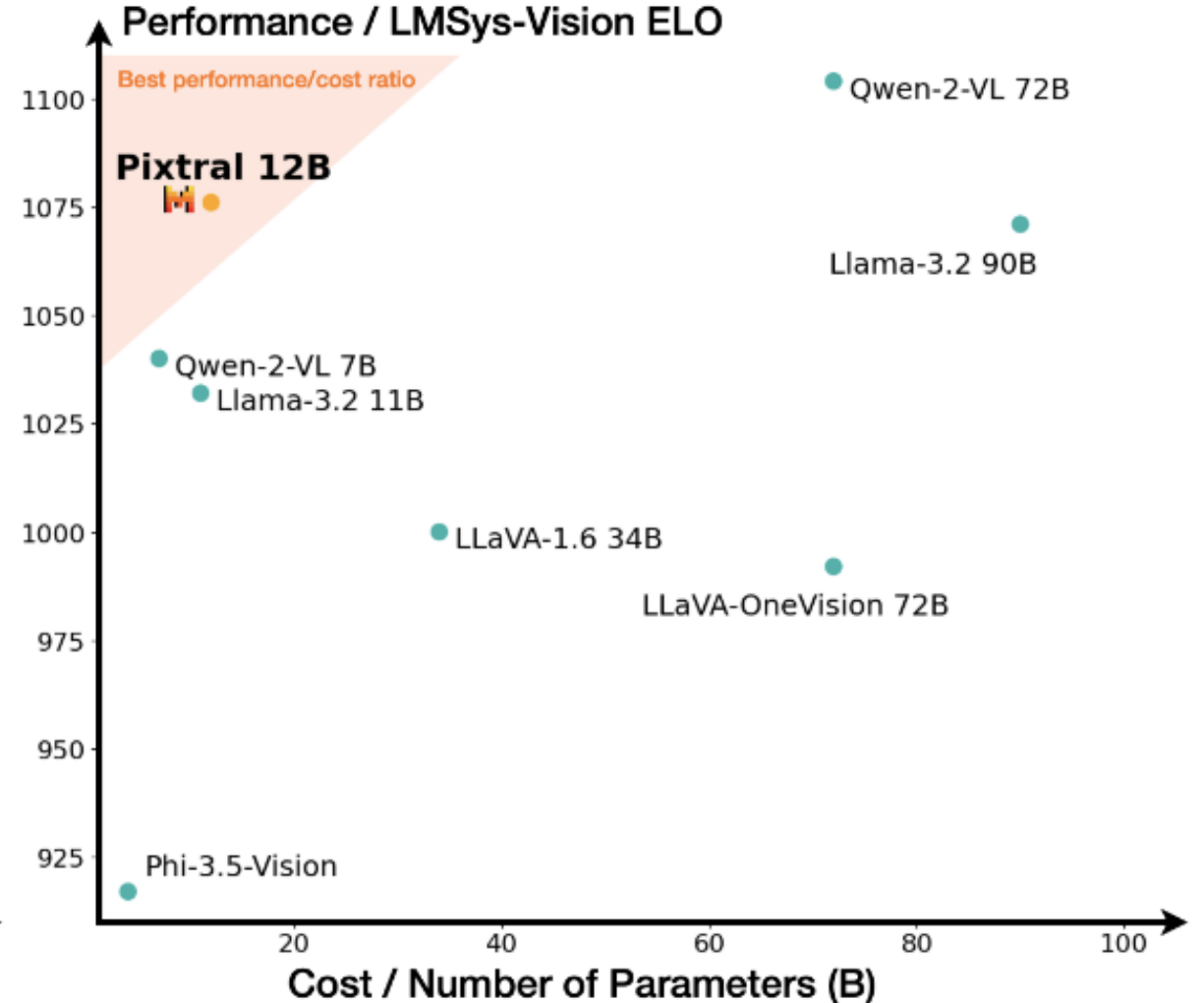
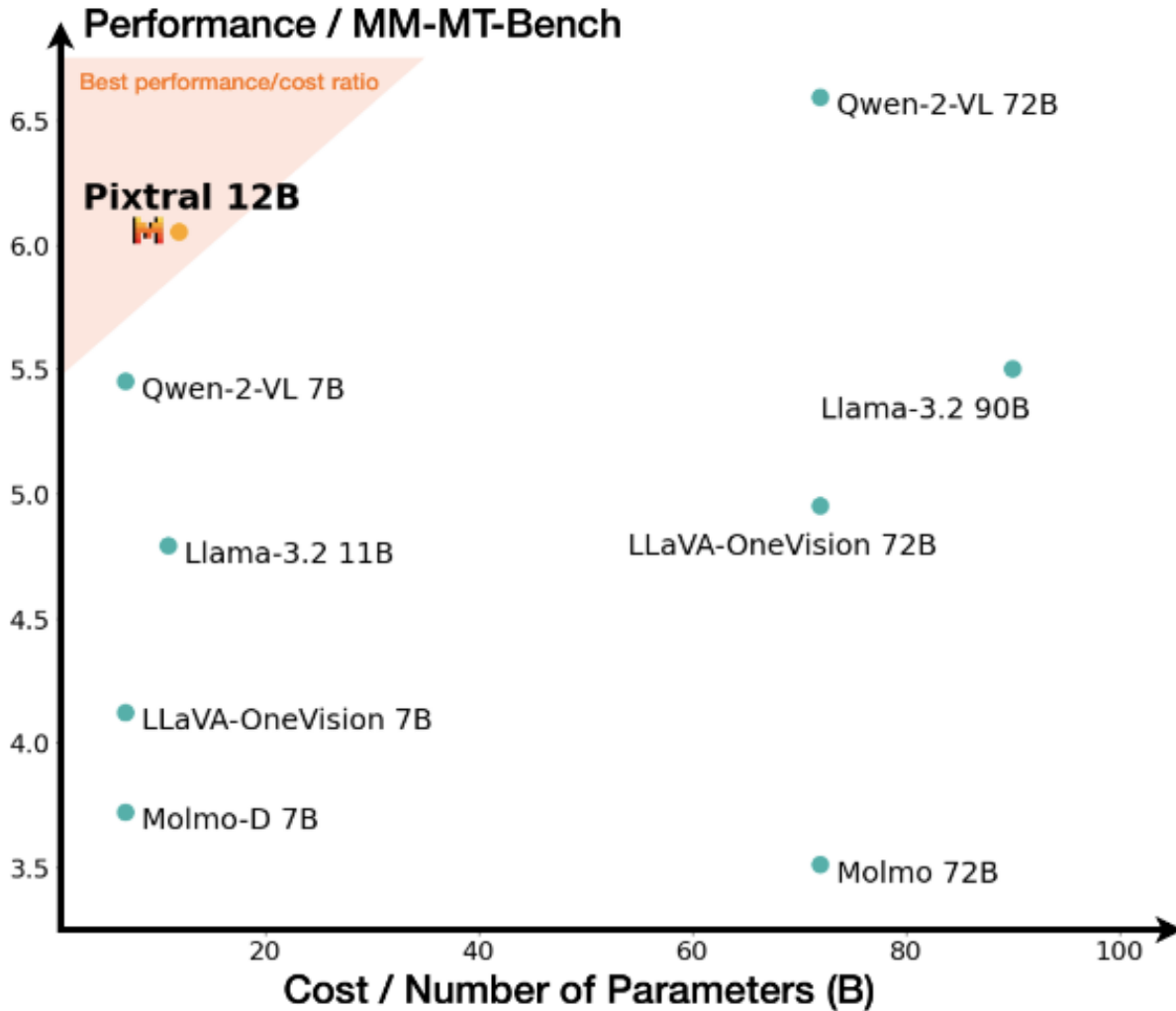

# Large Language Models (LLMs) Artificial Analysis Quality Index

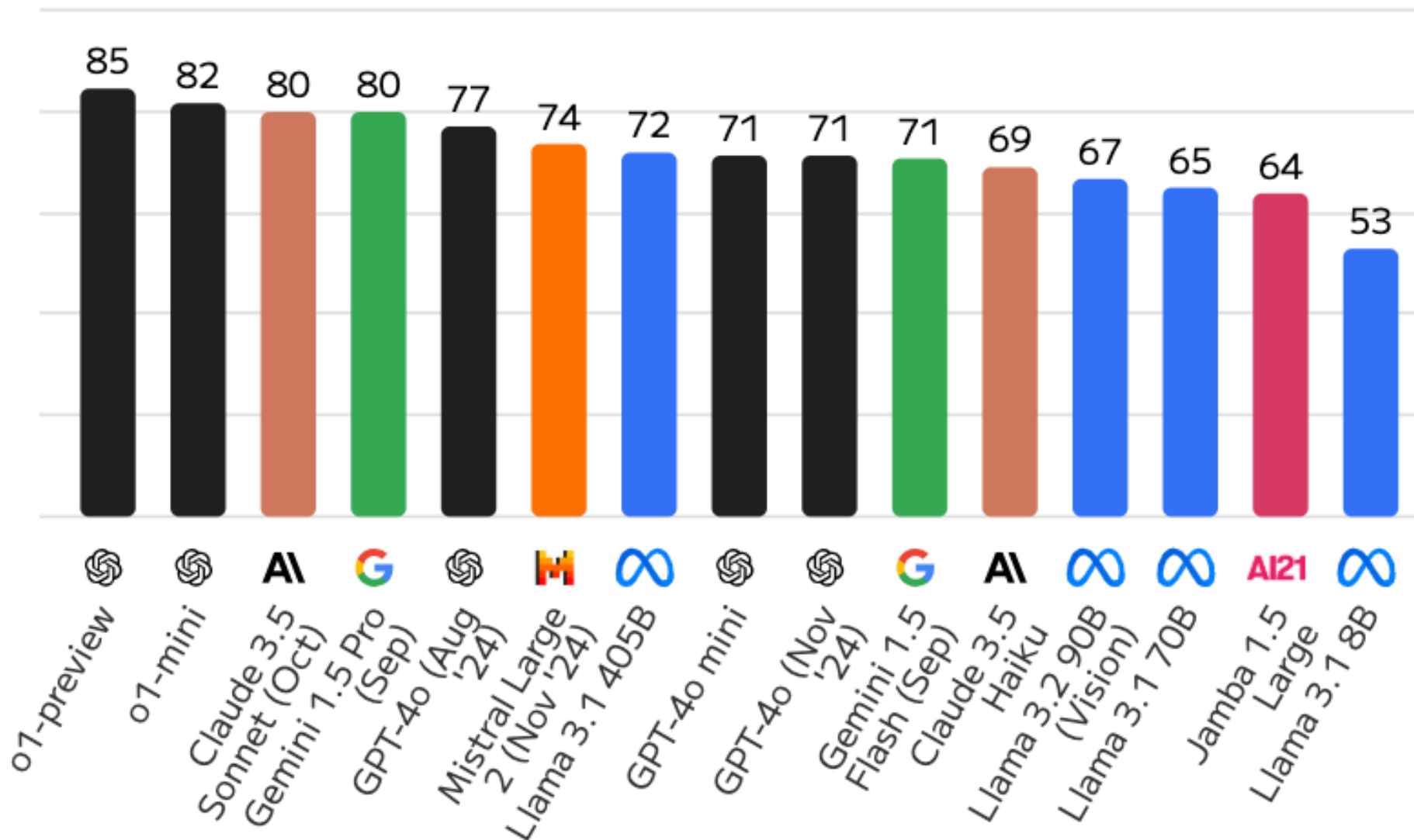

# Large Language Models (LLMs)

## Quality vs. Price

Artificial Analysis Quality Index, Price: USD per 1M Tokens

Most attractive quadrant

- o1-preview
- o1-mini
- GPT-4o (Aug '24)
- GPT-4o mini
- GPT-4o (Nov '24)
- Llama 3.1 405B
- Llama 3.2 90B (Vision)
- Llama 3.1 70B
- Llama 3.1 8B
- Gemini 1.5 Pro (Sep)
- Gemini 1.5 Flash (Sep)
- Claude 3.5 Sonnet (Oct)
- Claude 3.5 Haiku
- Mistral Large 2 (Nov '24)
- Jamba 1.5 Large



# Chat with Open Large Language Models: Chatbot Arena

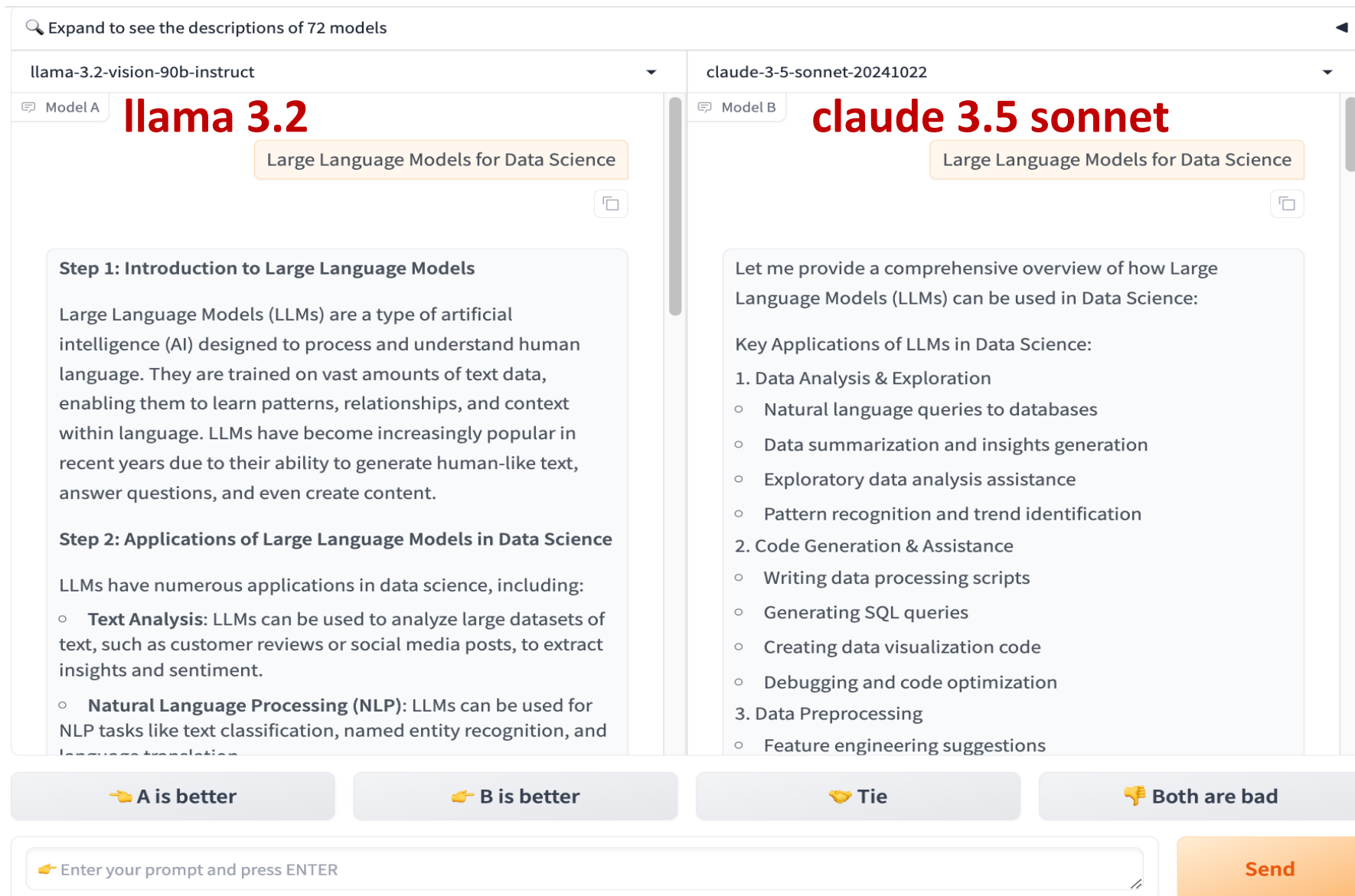

The screenshot shows the Chatbot Arena interface with two models being compared. The prompt is "Large Language Models for Data Science".

**Model A: llama 3.2**

**Step 1: Introduction to Large Language Models**

Large Language Models (LLMs) are a type of artificial intelligence (AI) designed to process and understand human language. They are trained on vast amounts of text data, enabling them to learn patterns, relationships, and context within language. LLMs have become increasingly popular in recent years due to their ability to generate human-like text, answer questions, and even create content.

**Step 2: Applications of Large Language Models in Data Science**

LLMs have numerous applications in data science, including:

- **Text Analysis:** LLMs can be used to analyze large datasets of text, such as customer reviews or social media posts, to extract insights and sentiment.
- **Natural Language Processing (NLP):** LLMs can be used for NLP tasks like text classification, named entity recognition, and language translation.

**Model B: claude 3.5 sonnet**

Let me provide a comprehensive overview of how Large Language Models (LLMs) can be used in Data Science:

**Key Applications of LLMs in Data Science:**

1. Data Analysis & Exploration
  - Natural language queries to databases
  - Data summarization and insights generation
  - Exploratory data analysis assistance
  - Pattern recognition and trend identification
2. Code Generation & Assistance
  - Writing data processing scripts
  - Generating SQL queries
  - Creating data visualization code
  - Debugging and code optimization
3. Data Preprocessing
  - Feature engineering suggestions

<https://lmarena.ai/>

# Perplexity.ai



Anonymous Like

Share

New Thread

Home

Discover

Library

Login

Sign Up

Try Pro  
Upgrade to Claude-2 or GPT-4, boost Copilot uses, and upload more files.  
Learn More

Download

## Large Language Models for Data Science

### Sources

- What Is a Large Language Model and What Can... snowflake · 1
- What are Large Language Models? | NVIDIA nvidia · 2
- Catch Up On Large Language Models | by... towardsdatascien... · 3
- View 3 more

### Answer

Large Language Models (LLMs) are advanced AI systems designed to understand human language intricacies and generate intelligent, creative responses to queries <sup>1</sup>. They are deep learning algorithms that can recognize, summarize, translate, predict, and generate content using very large datasets <sup>2</sup>. LLMs are trained on enormous data sets typically measured in petabytes, sourced from books, articles, websites, and other text-based sources <sup>1</sup>. They are dynamic tools that are continuously updated and refined as new data becomes available <sup>1</sup>.

In the field of data science, LLMs can potentially transform how teams source, manage, and analyze data <sup>1</sup>. They are used in numerous data science applications, and their ability to process and interpret vast amounts of text data has made them an indispensable part of

Ask follow-up... Copilot

social media posts or customer reviews, to determine whether the overall sentiment is

<https://www.perplexity.ai/>

# Generative AI (Gen AI)

## AI Generated Content (AIGC)

### Image Generation

**Instruction 1:**

*An astronaut riding a horse in a photorealistic style.*

**Instruction 2:**

*Teddy bears working on new AI research on the moon in the 1980s.*

Figure 1



Figure 2



 **OpenAI DALL·E 2**

# Generative AI (Gen AI)

## AI Generated Content (AIGC)

### Unimodal

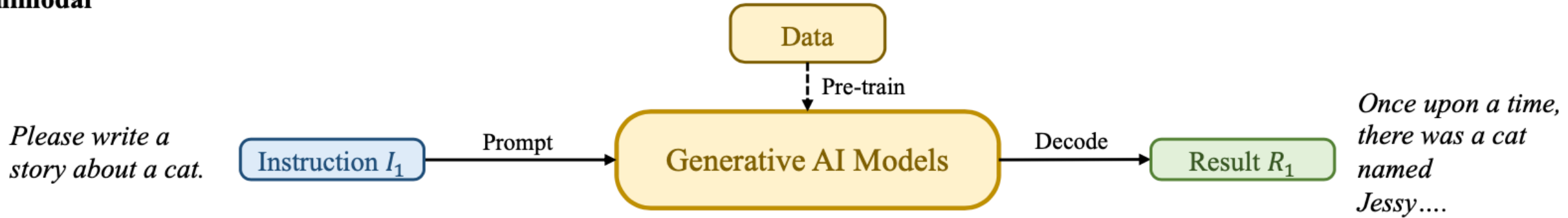

### Multimodal

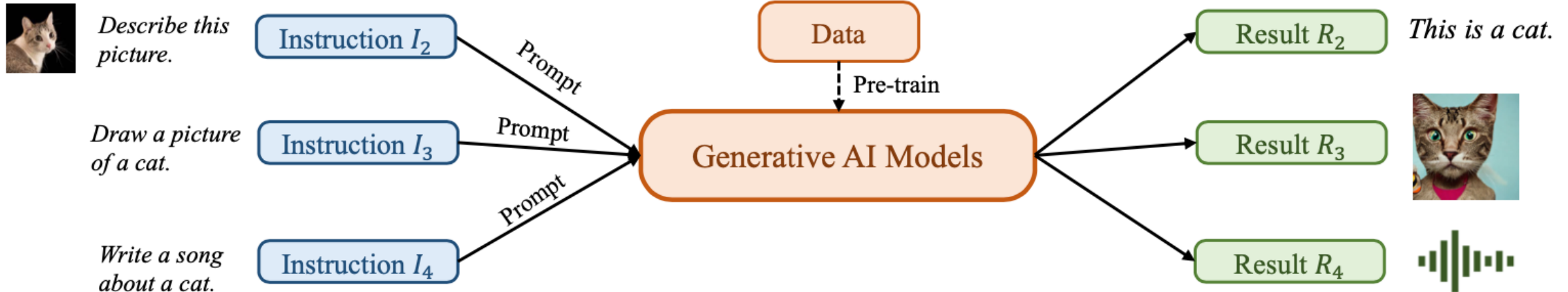

# The history of Generative AI in CV, NLP and VL

## Unimodal- CV & NLP

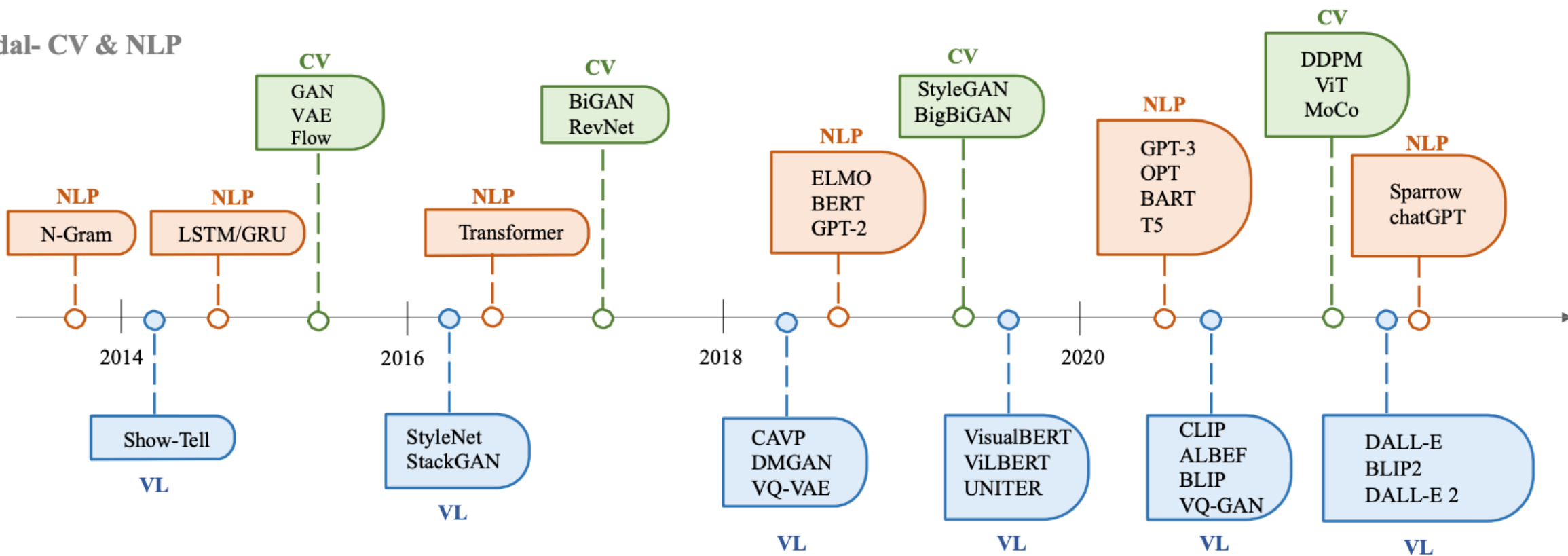

## Multimodal – Vision Language

# Generative AI Foundation Models

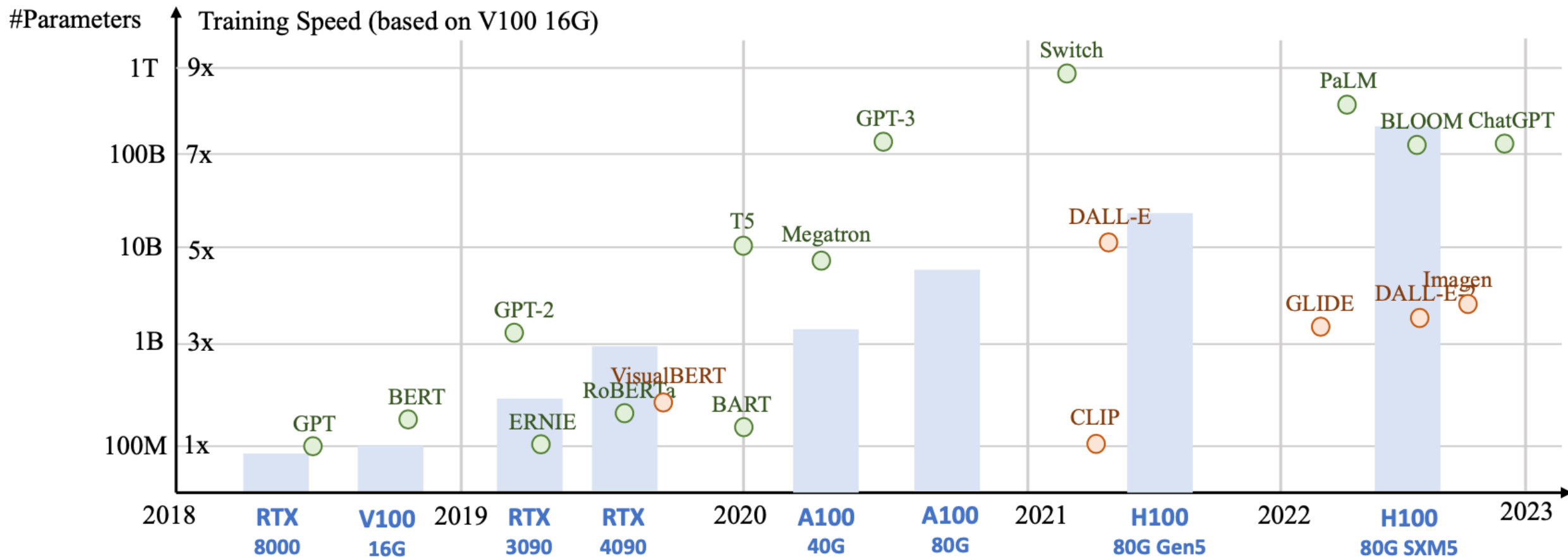

# Categories of Vision Generative Models

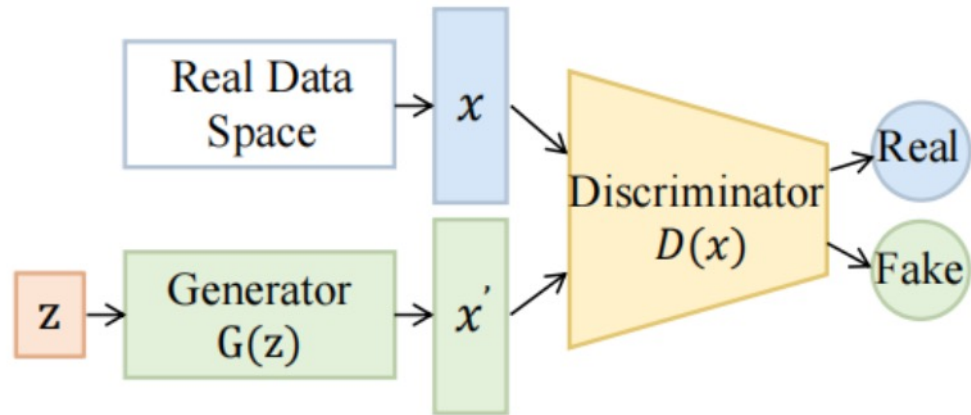

(1) Generative adversarial networks

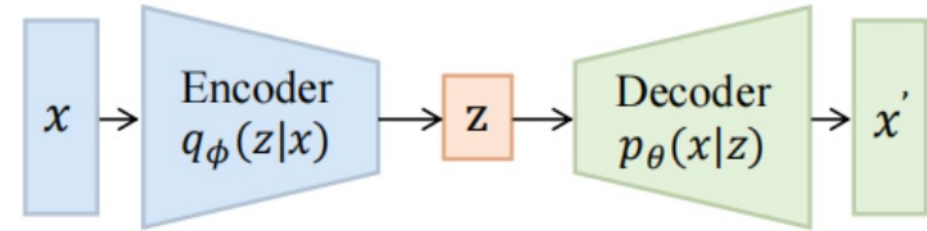

(2) Variational autoencoders

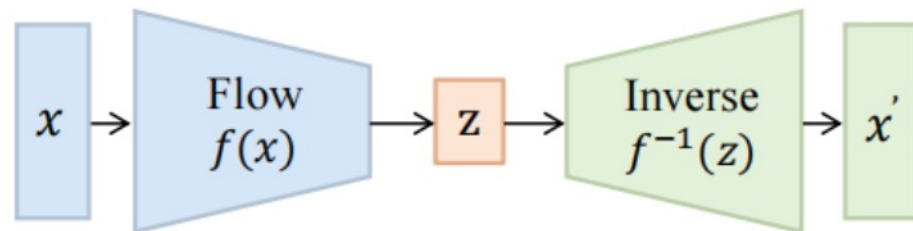

(3) Normalizing flows

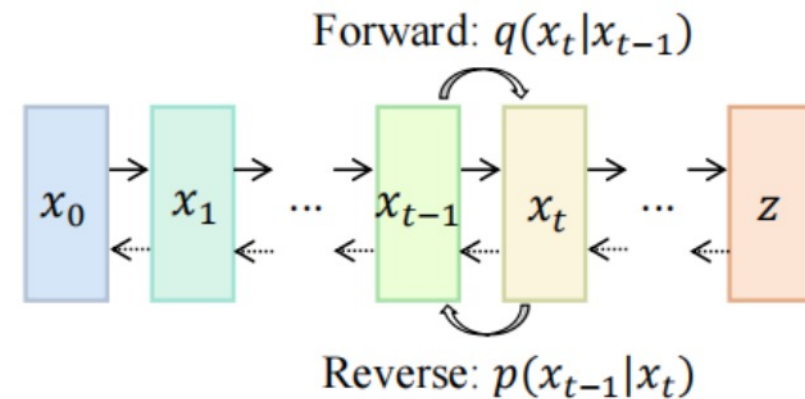

(4) Diffusion models

# The General Structure of Generative Vision Language

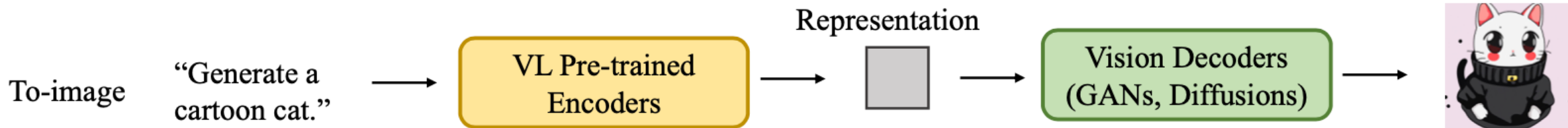
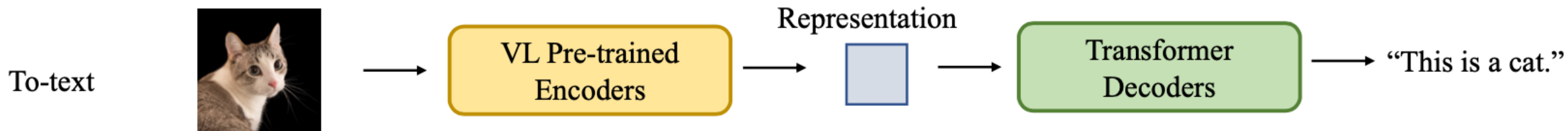
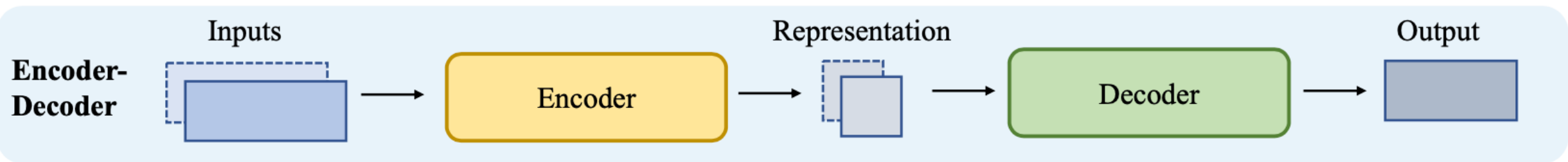

# Framework for Implementing Generative AI Services using RAG Model

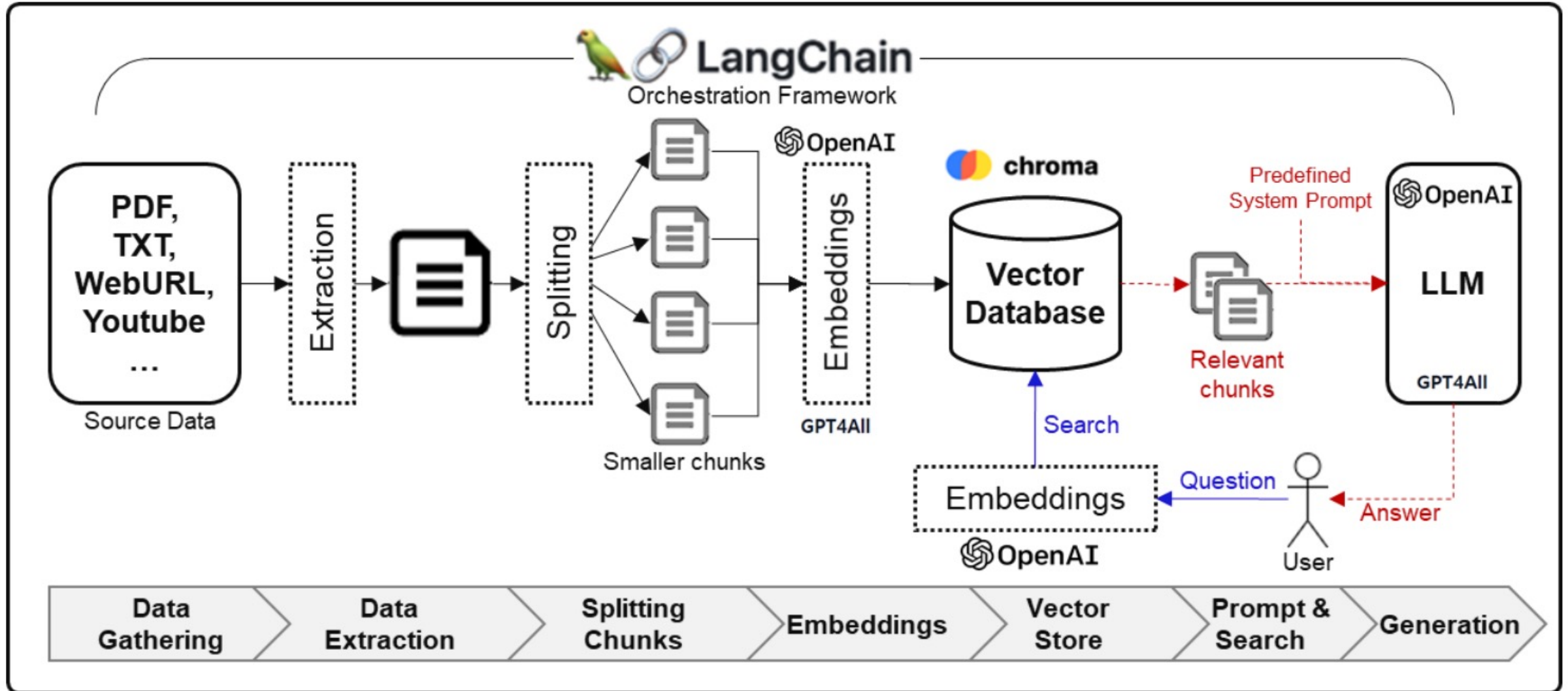

# Native RAG, Advanced RAG, Agentic RAG

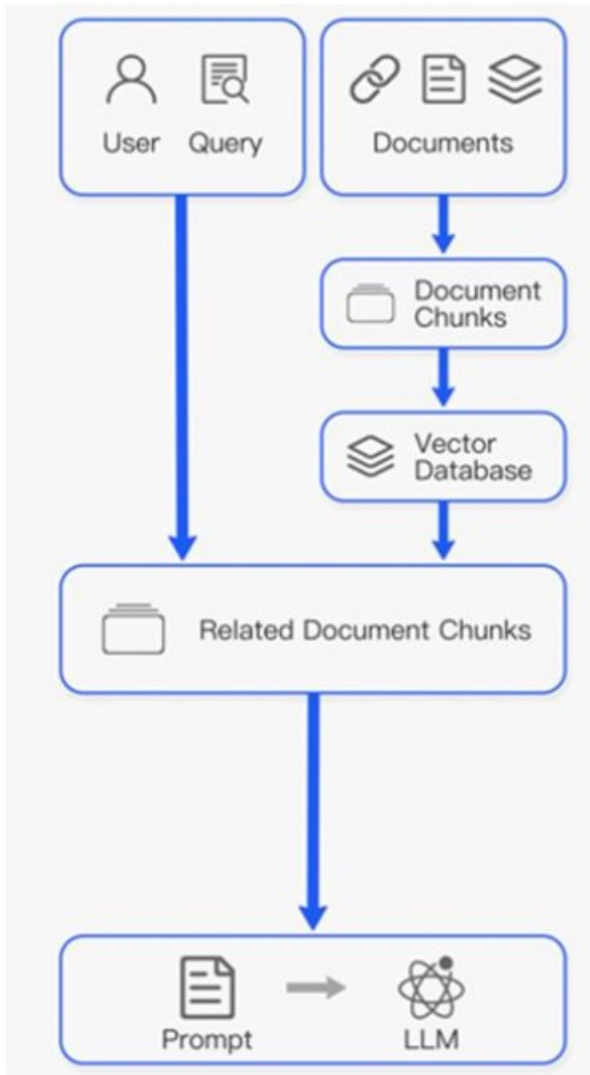

Native RAG

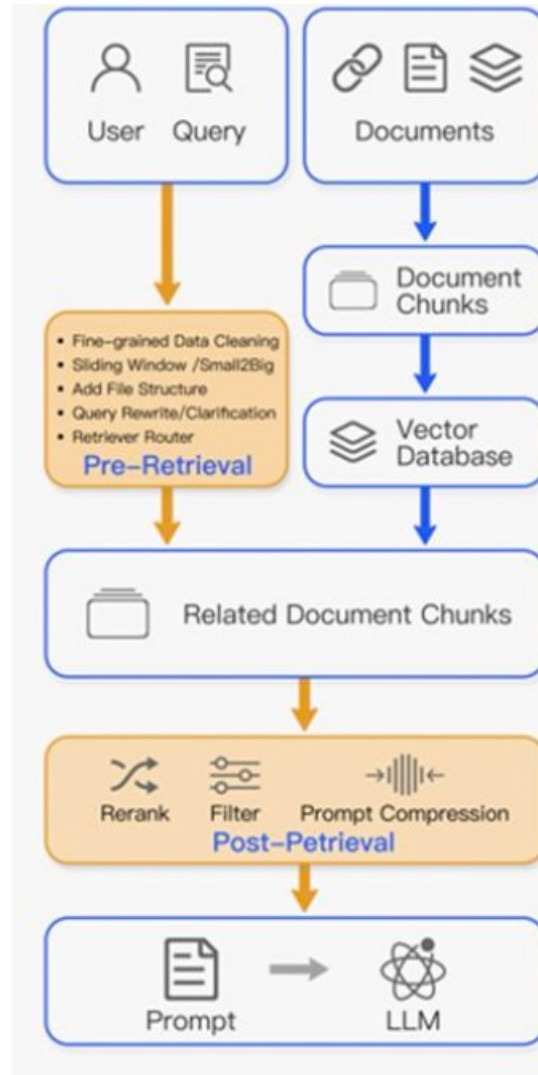

Advanced RAG

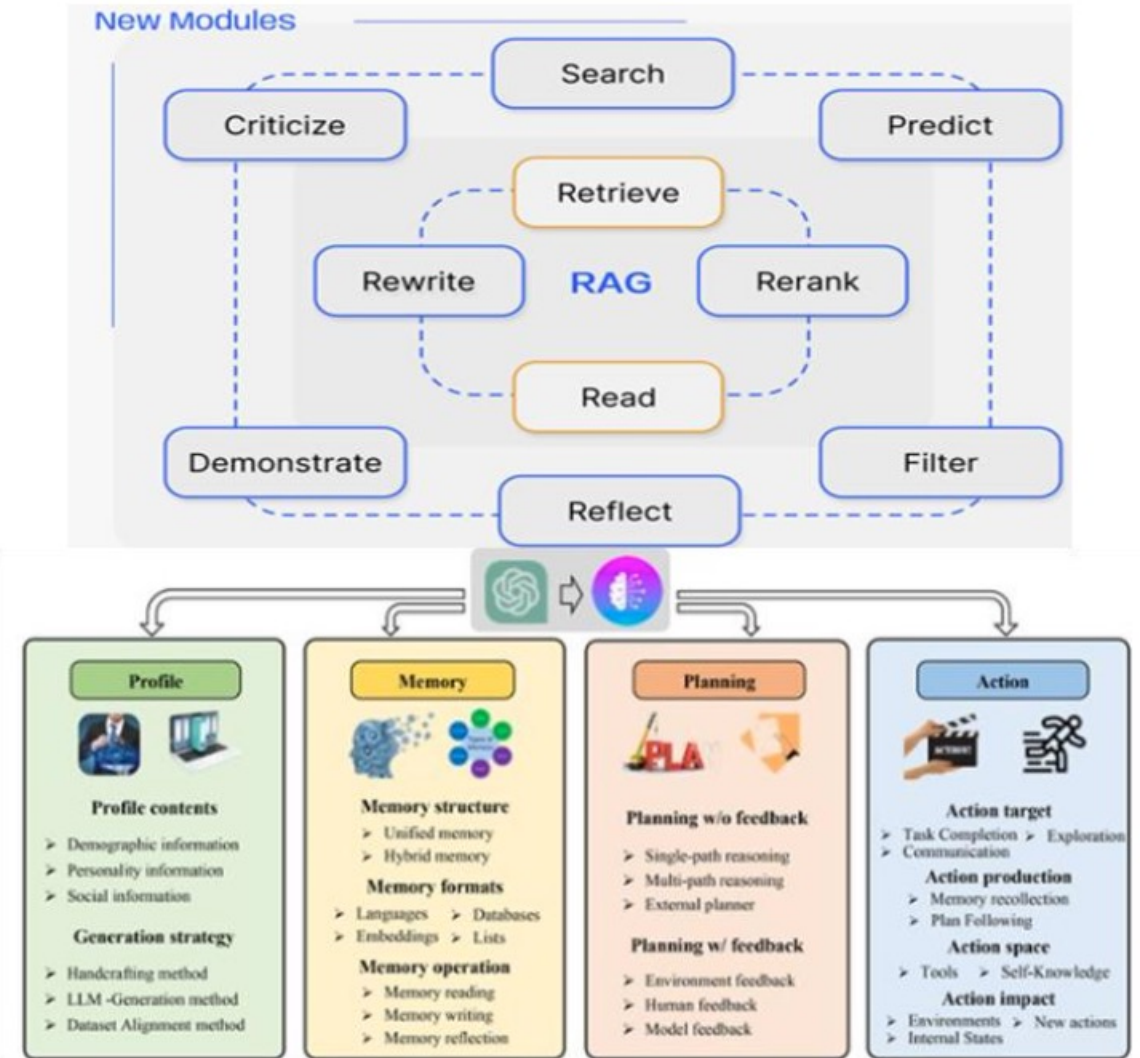

Modular + Agentic RAG

# Modular + Agentic RAG

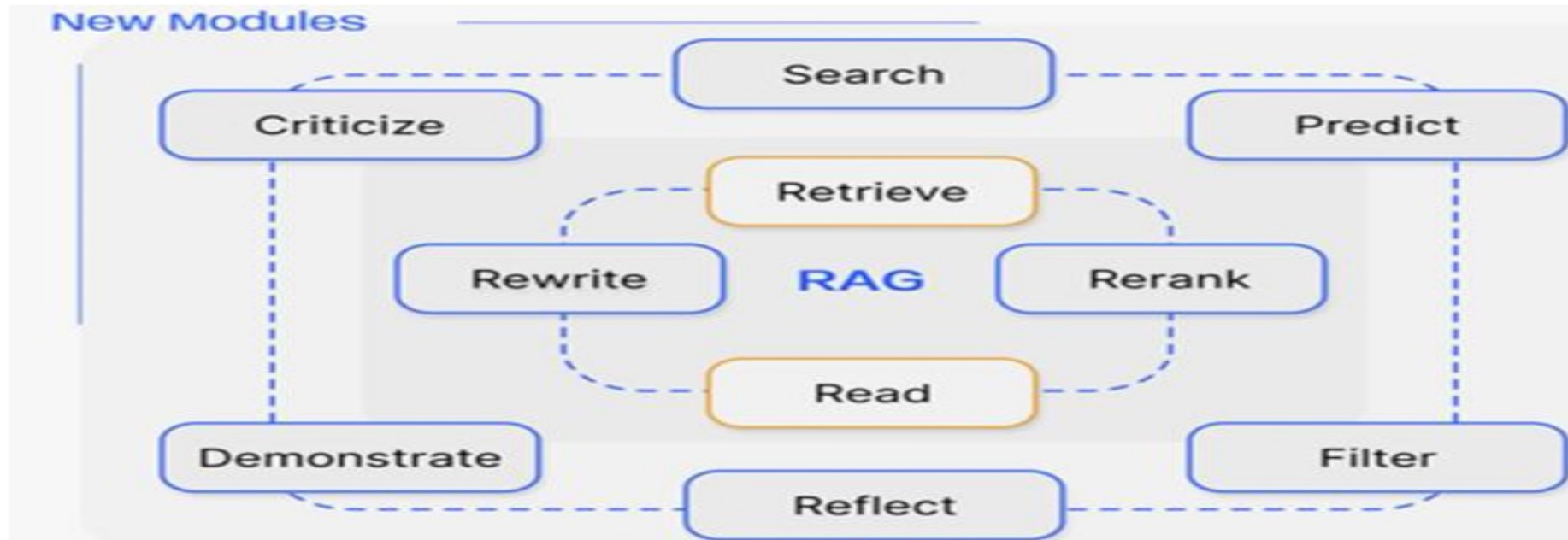

# LLM Prompt, RAG, Agent, Fine tuning

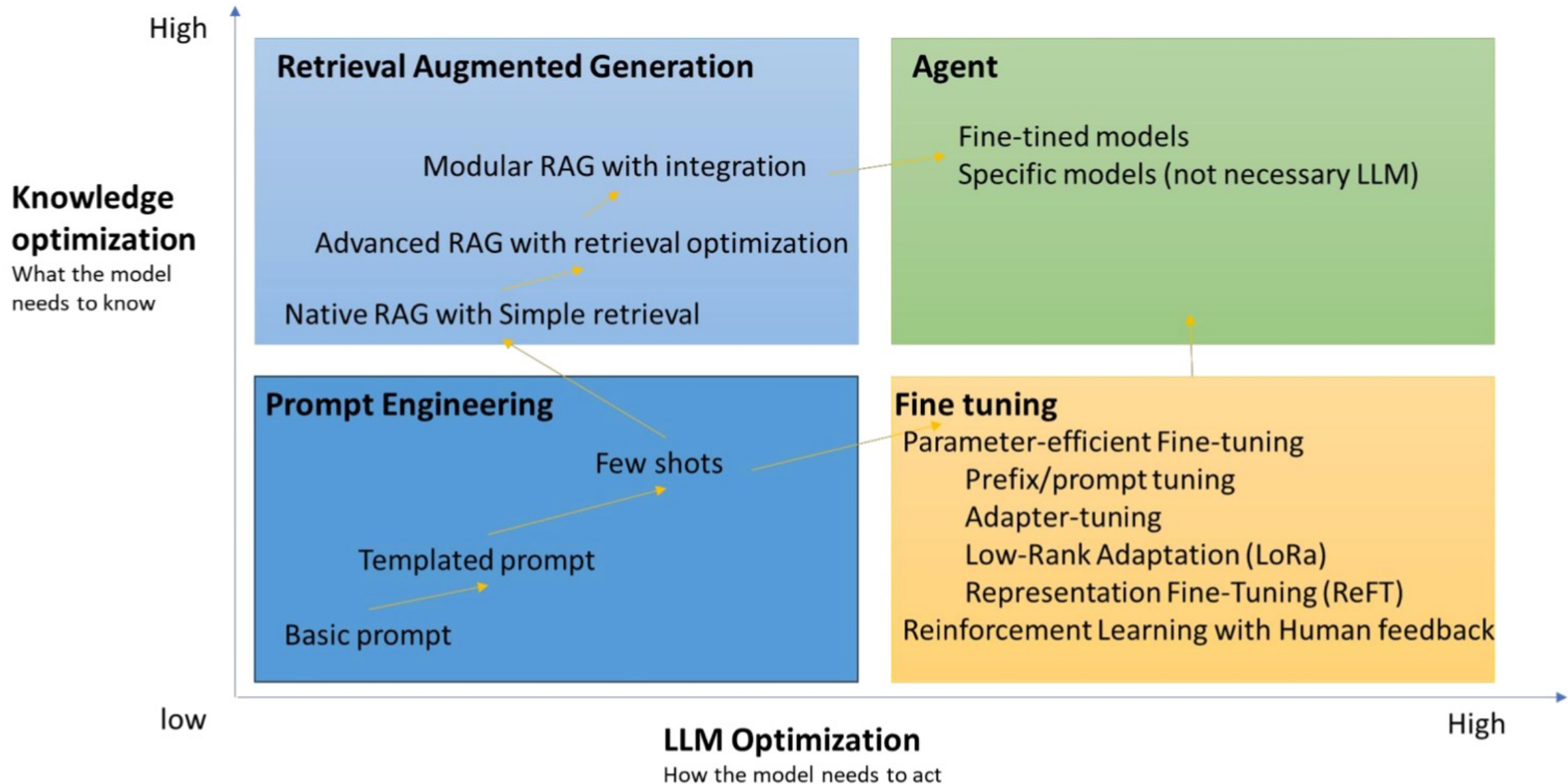

# LLM Decision Path for Suitable Techniques

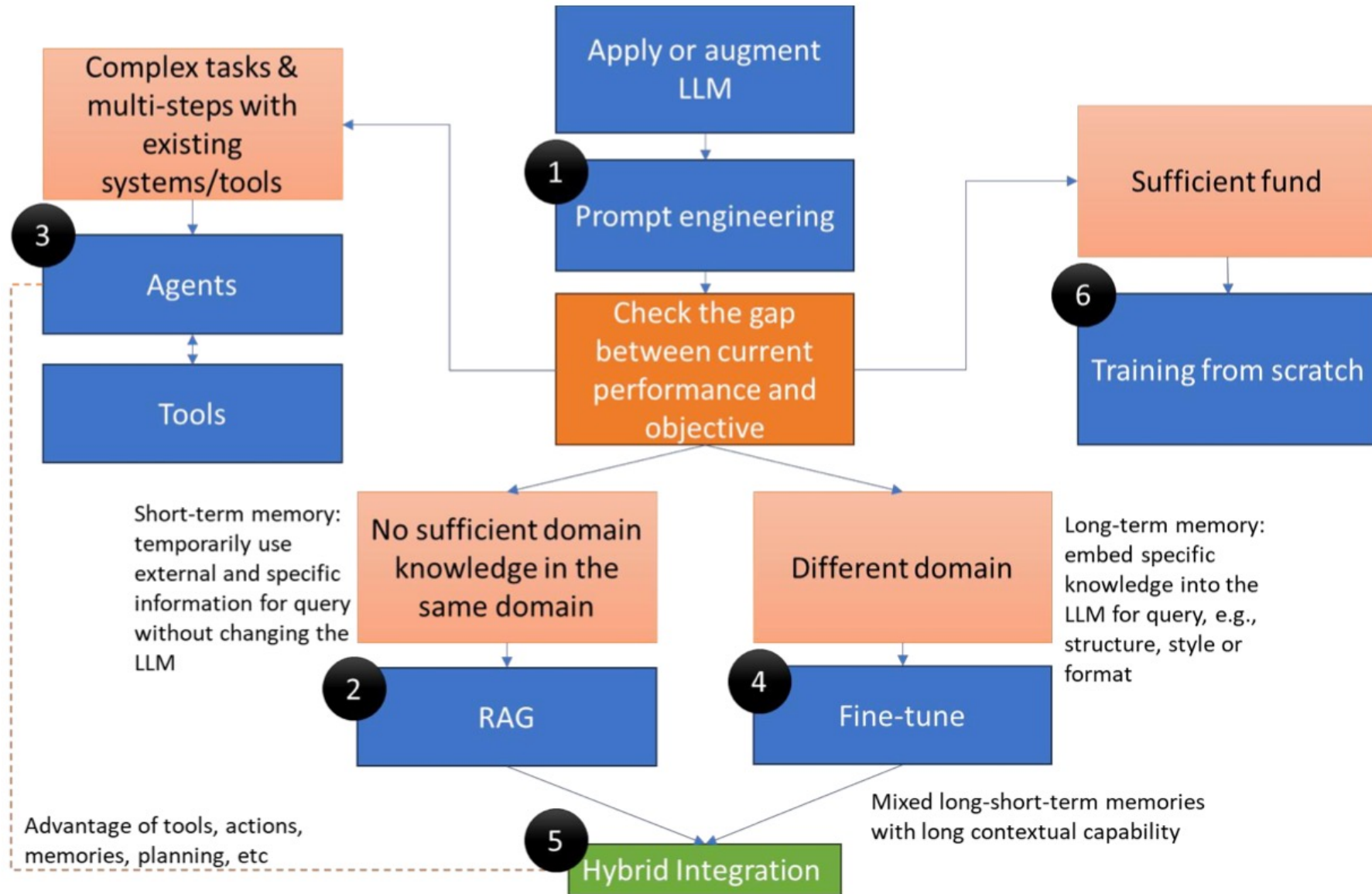

# LLM Stack

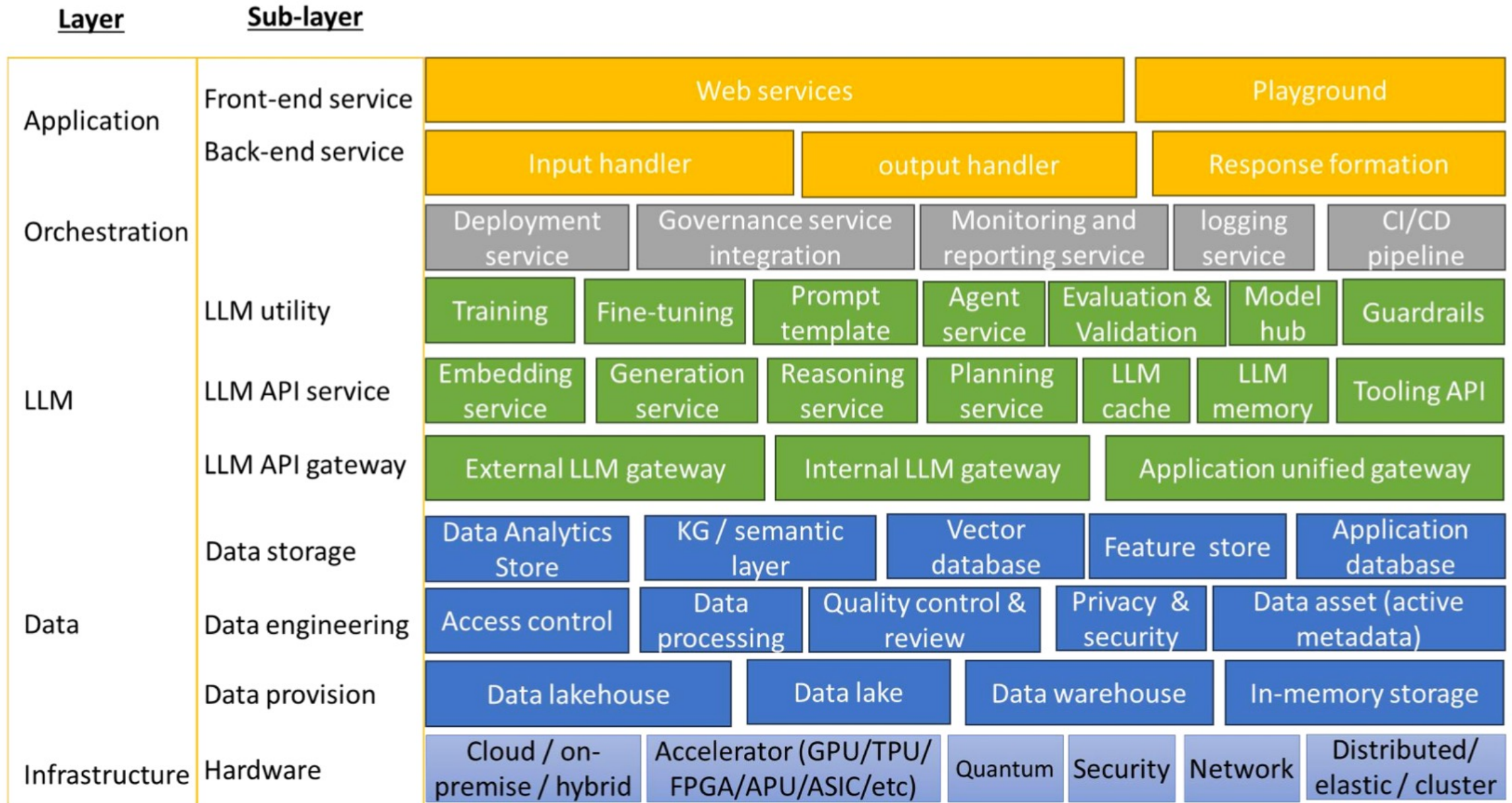

# LLM Functionalities

Service management

Scenario management	
Configuration	Task creation
Knowledge management	Application management
pipeline	Automated test

Model/data management		
Metadata / data annotation	Collaboration	Content moderation
Data mining & synthesis	Security and privacy: PII detection & masking	

Agent/prompt management		
Prompt studio / recipe	Agent studio / template	Tool management
NLP recipe	Safety and compliance	

Online services		
Security/personal Auth	Monitoring /Logging / cost reporting	audit trail
guardrails	Validation evaluation	
QC	API gateway	

Engineering

Prompt engineering	
Zero-short/ few-short	Chain/tree/graph-of-thought
Pattern-based template: co-star/automate	self-criticism / role-playing

RAG engineering		
Query rewriting	Routing	Rerank
Auto-merging	Recursive	Hybrid fusion
compression		Dense x

Agent engineering		
ReAct	self-criticism	memory
tooling	planning	decision
workflow	collaboration	

Fine-tuning engineering		
LoRa / QLoRa	quantization	SFT / RLHF
distillation	ReFT	Adaptor
PEFT	ZeRo /DeepSpeed	

Technology foundation

LLM (generation)		
OpenAI	Gemini / gemma	Claudia
ChatGLM	Llama	Mistral / Mixtral
Phi-MoE	Yi / Qwen	WizardLM
deepseek	Kimi	Blossom

Embedding	
BGE	FinGPT
Bert/ FinBert	M3E / ERNIE
Core algorithms	
Context fusion	memory
multimodal	Long context

Framework	
Langchain	Lammaindex
GPTflow	graphGPT
AutoAgent	HF Agents
Langroid	Haystack

Vector database		
pinecore	Chroma	pgvector
Faiss	Milvus	Qdrant
Feature store		
Feathr	Databricks	Feast
Vertex AI FS	Hopsworks	AWS FS

Source: Jun Xu (2024). "GenAI and LLM for Financial Institutions: A Corporate Strategic Survey." Available at SSRN 4988118.

# Factuality Enhancement of Large Language Models (LLMs)

## Factuality Enhancement of Large Language Models

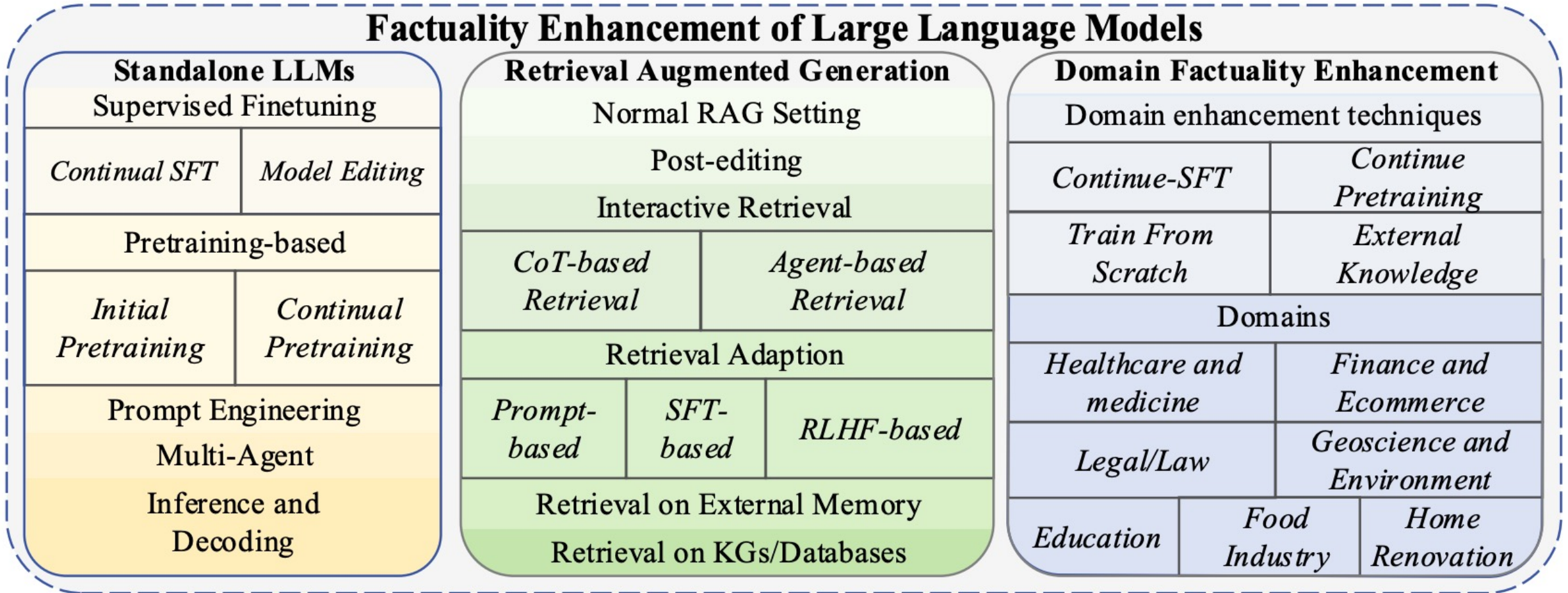

# Large Language Model (LLM) based Agents

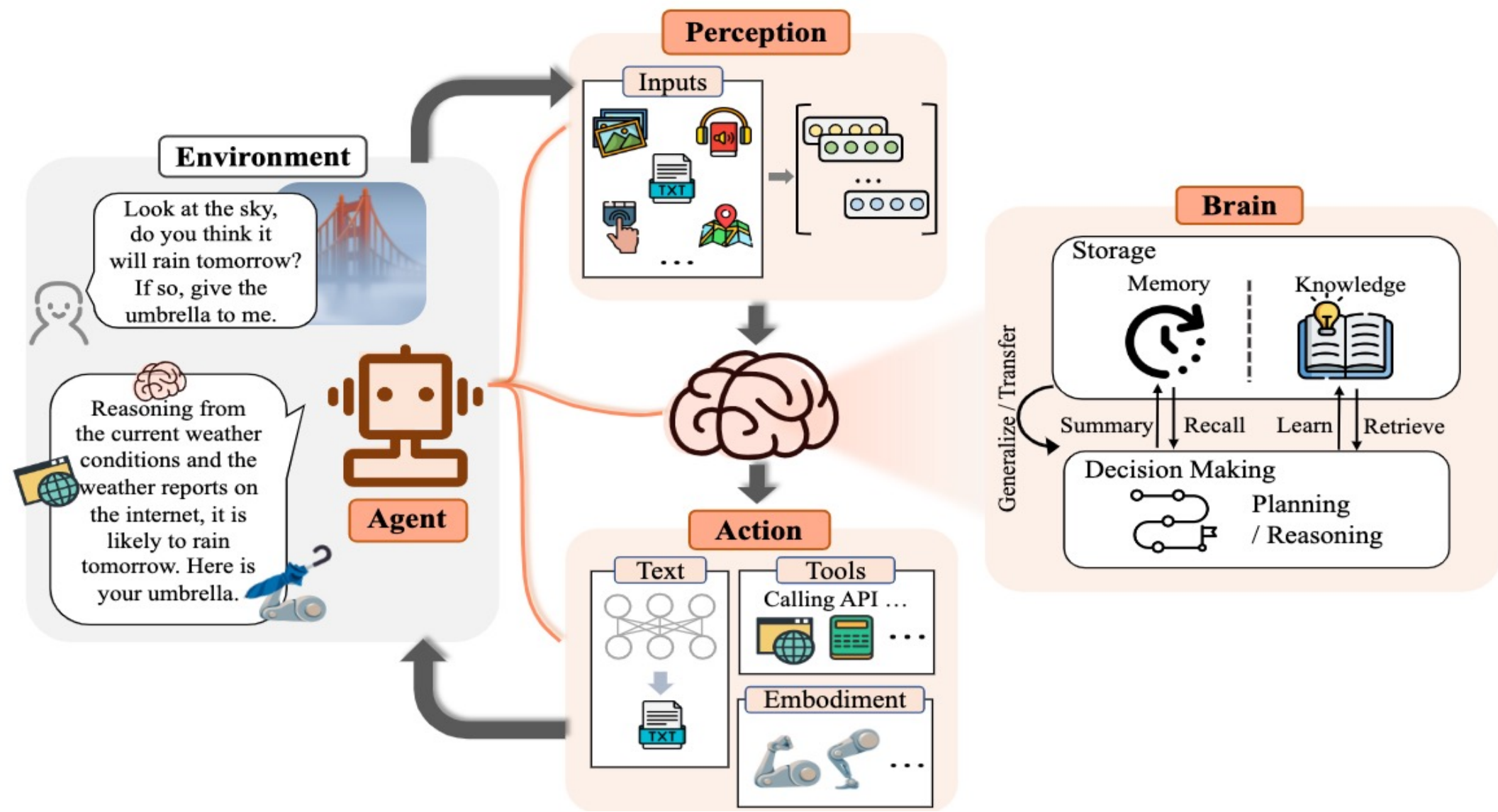

# LLM-based Agents

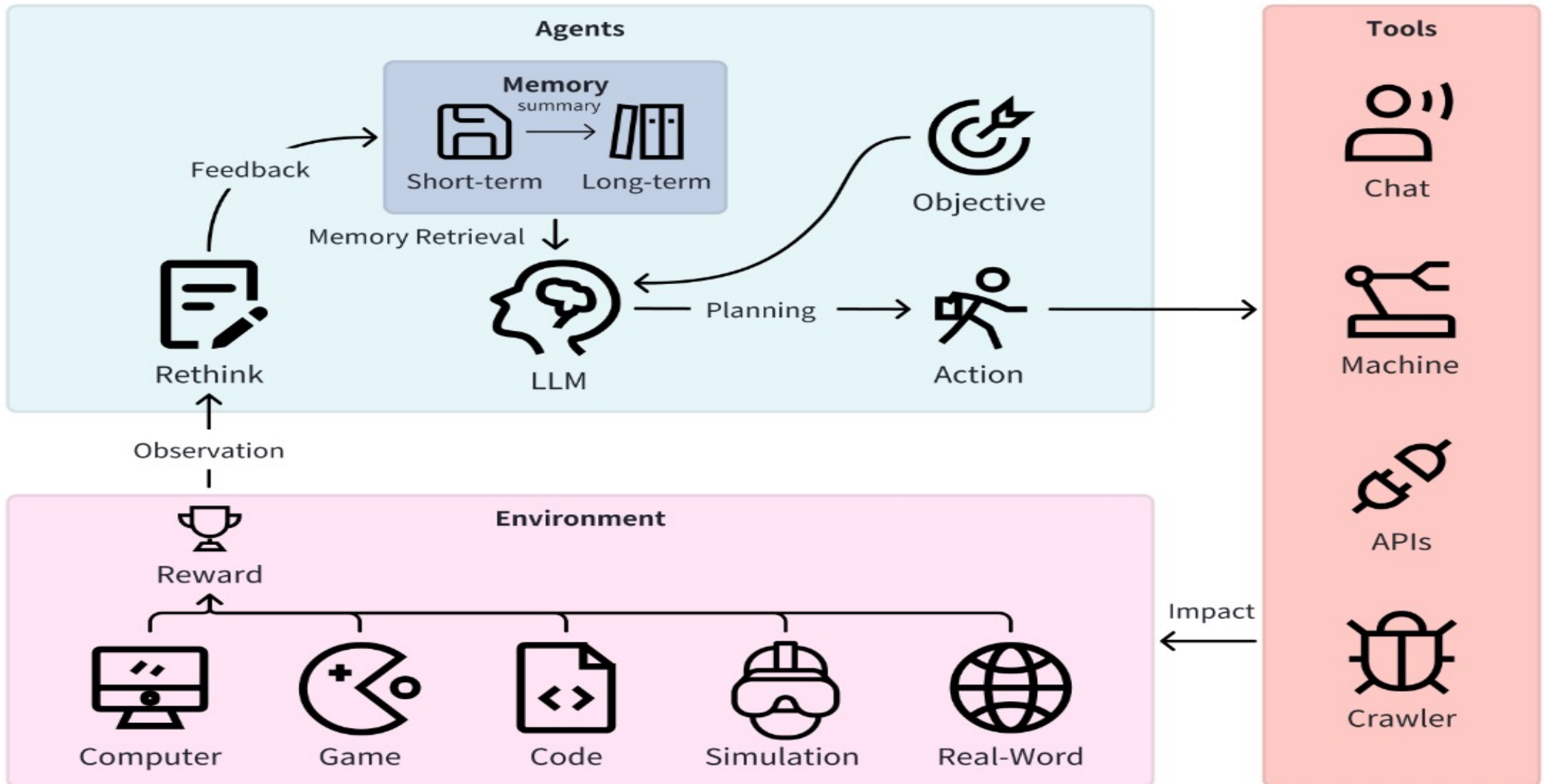

# Large Multimodal Agents (LMA)

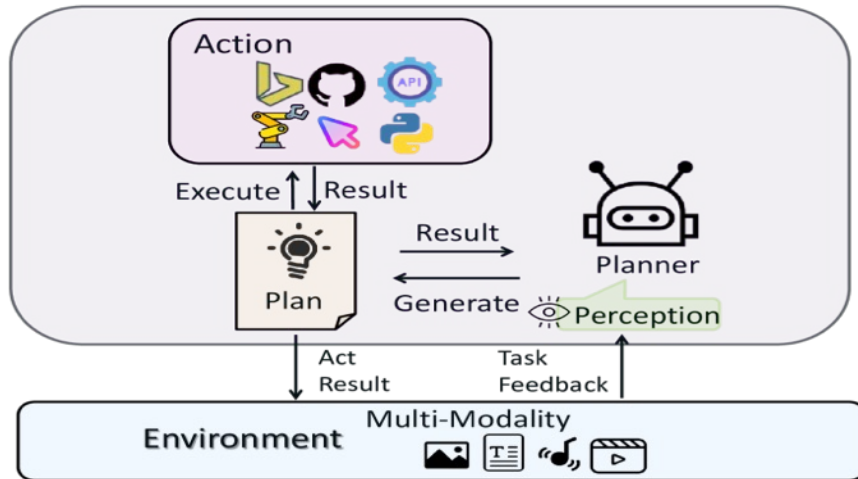

(a)

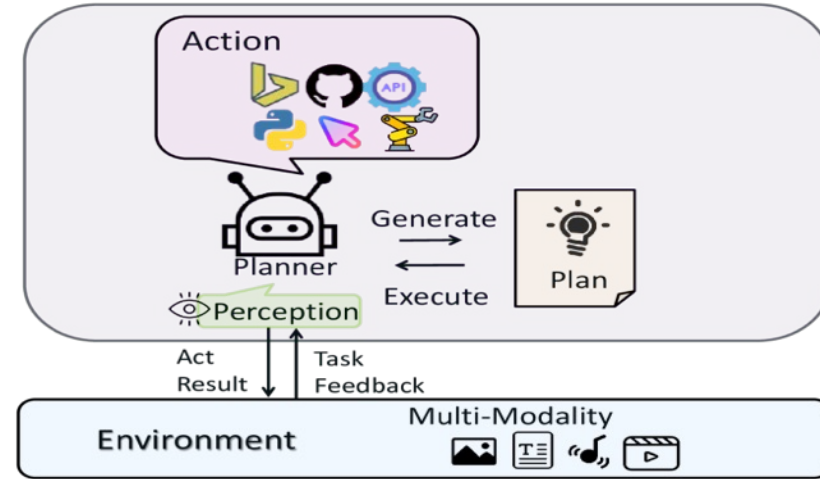

(b)

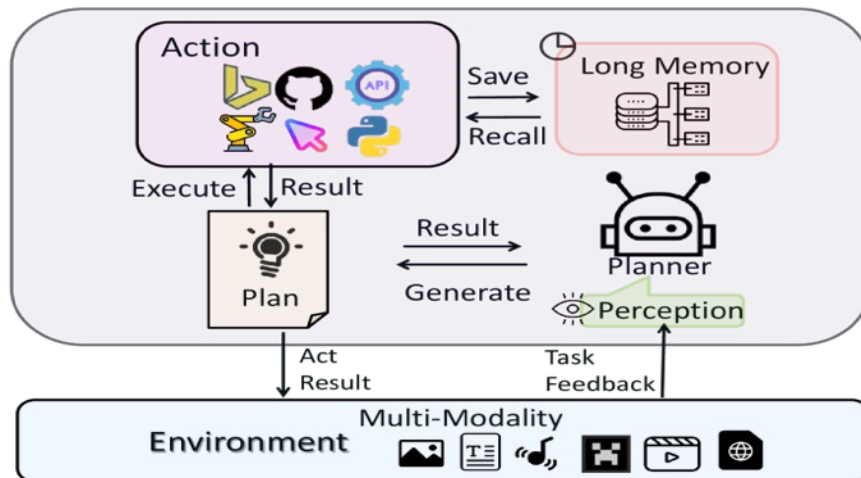

(c)

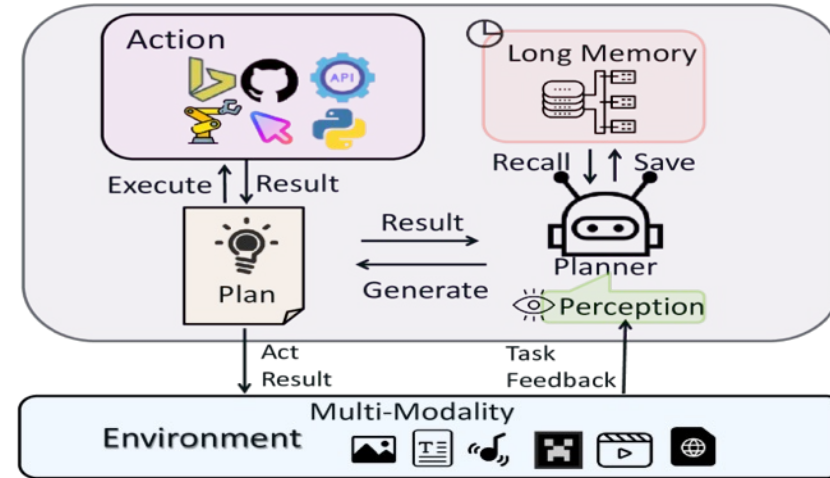

(d)

# Large Multimodal Agents (LMA)

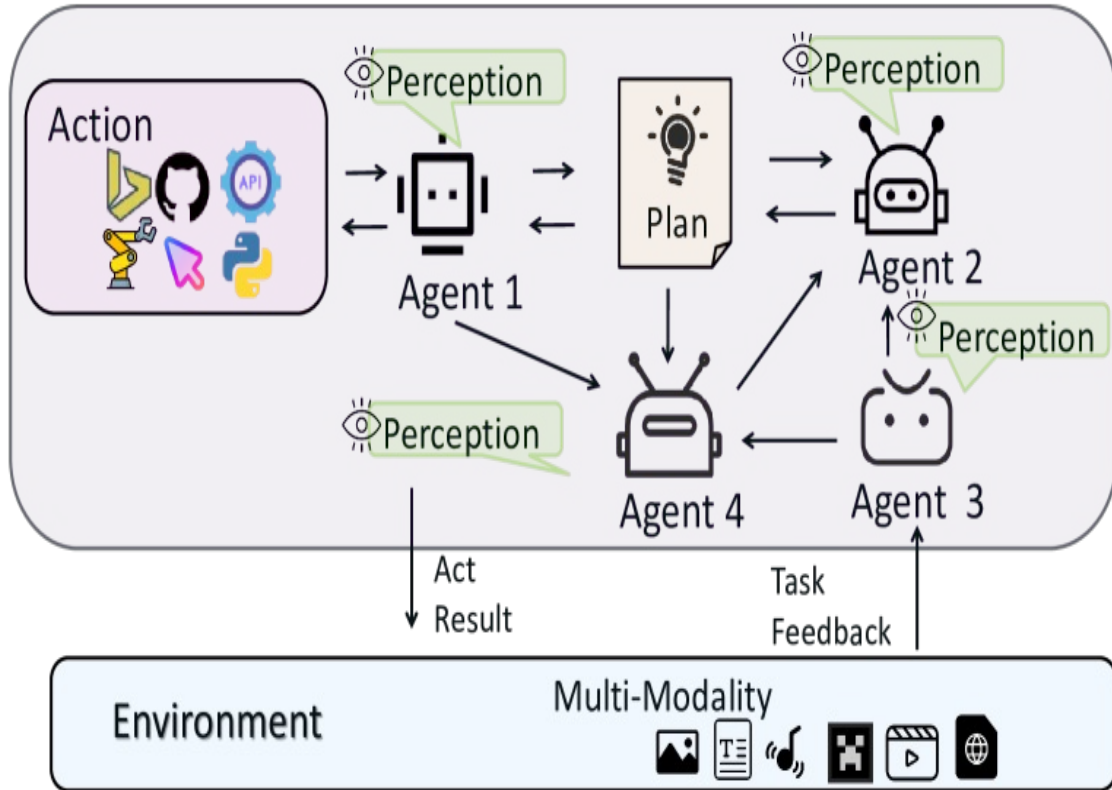

(a)

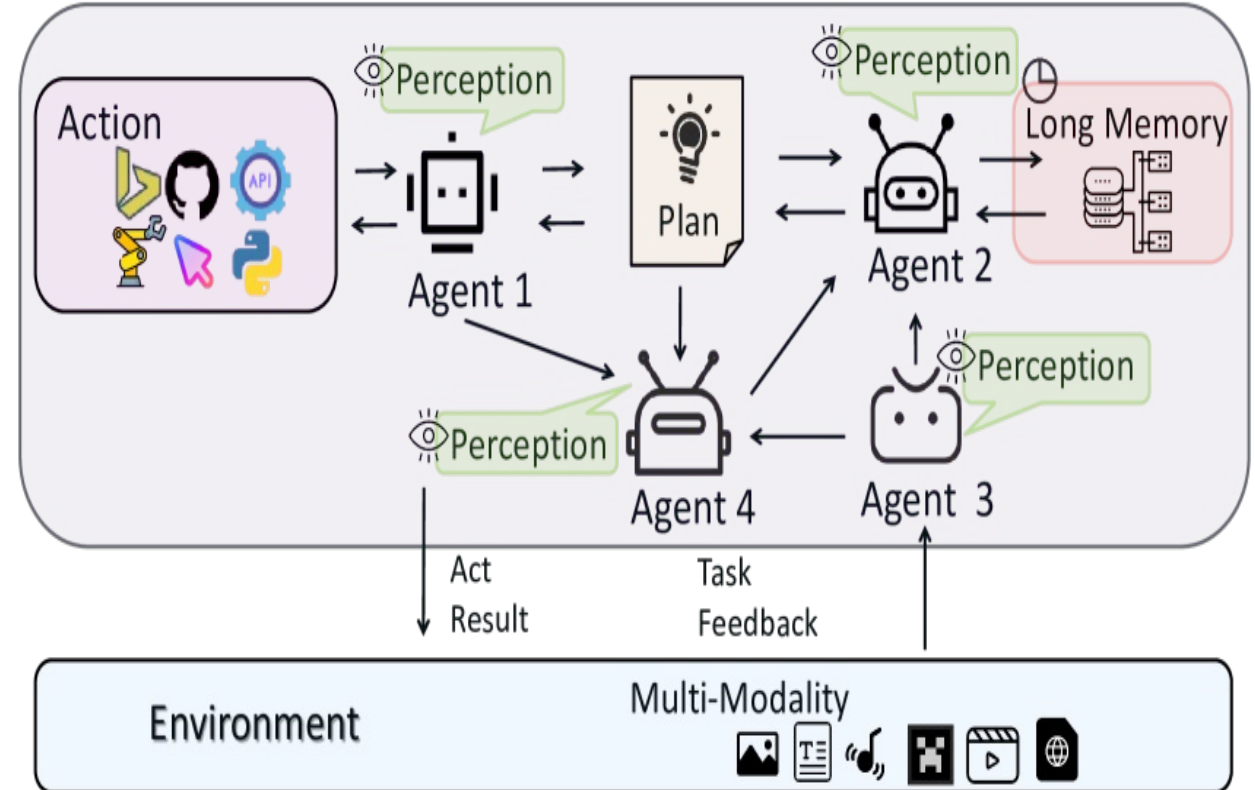

(b)



# Financial Large Language Models (Fin LLMs)

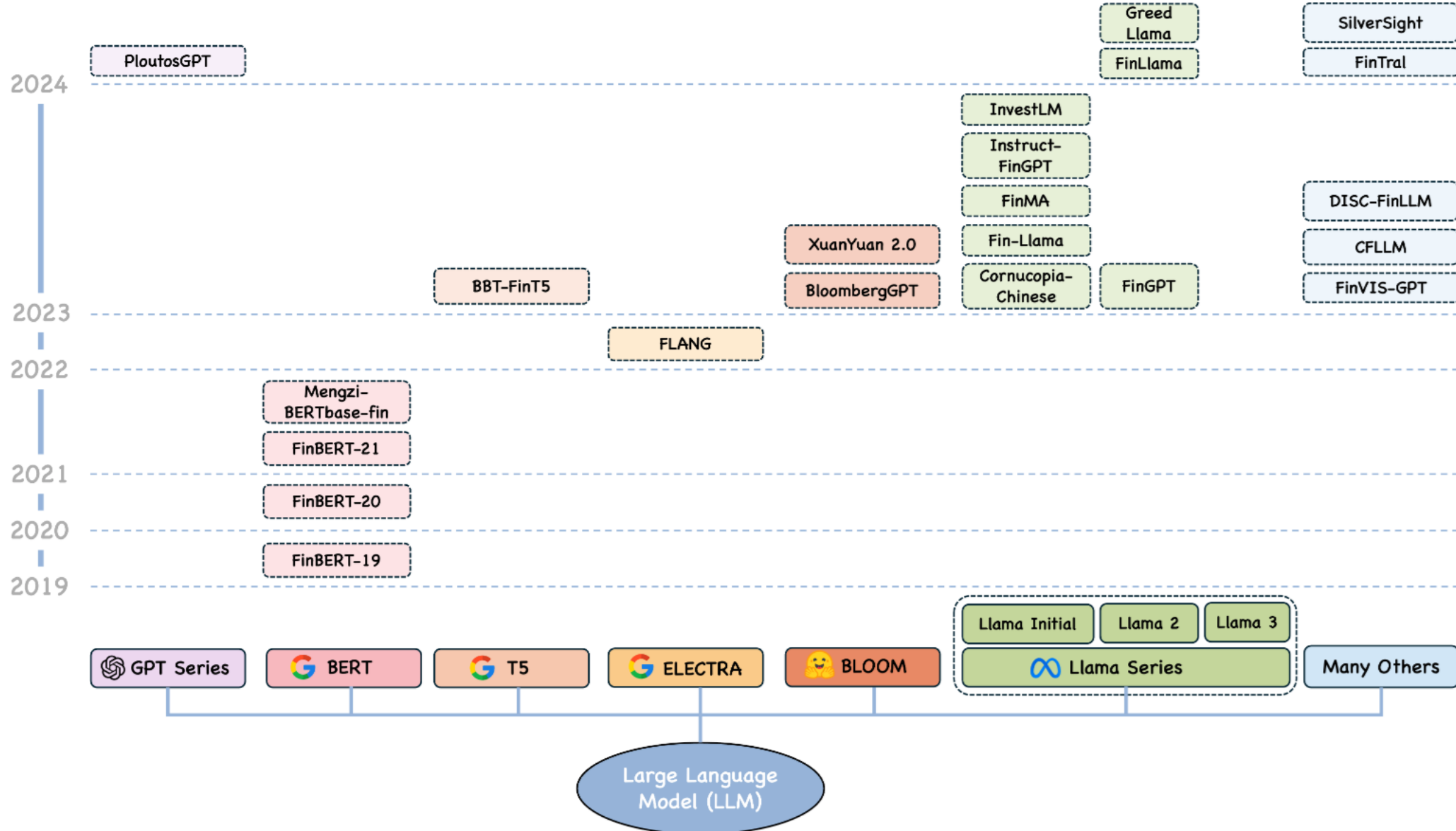

Source: Yuqi Nie, Yaxuan Kong, Xiaowen Dong, John M. Mulvey, H. Vincent Poor, Qingsong Wen, and Stefan Zohren (2024). "A Survey of Large Language Models for Financial Applications: Progress, Prospects and Challenges." arXiv preprint arXiv:2406.11903.

# Financial Reasoning Tasks

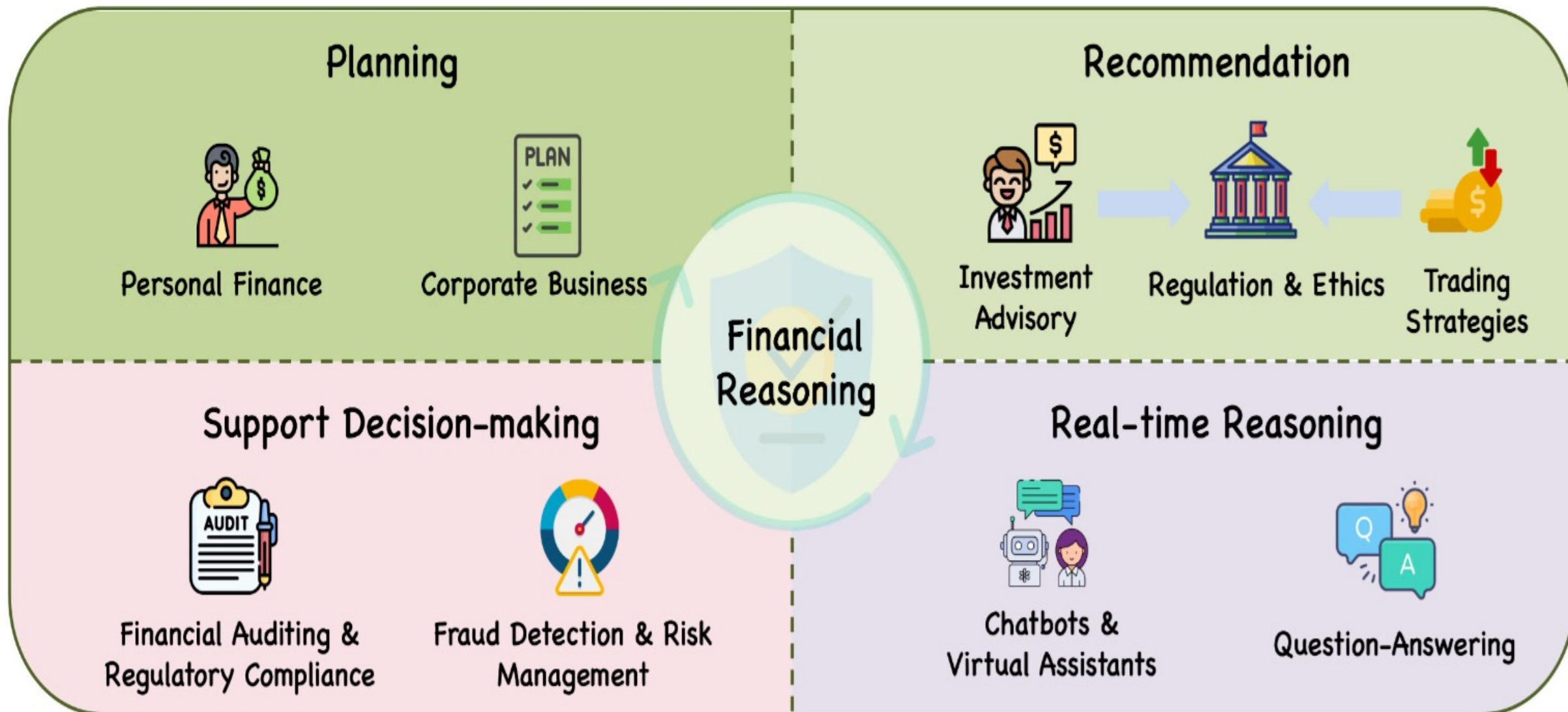

# Financial LLM Agent

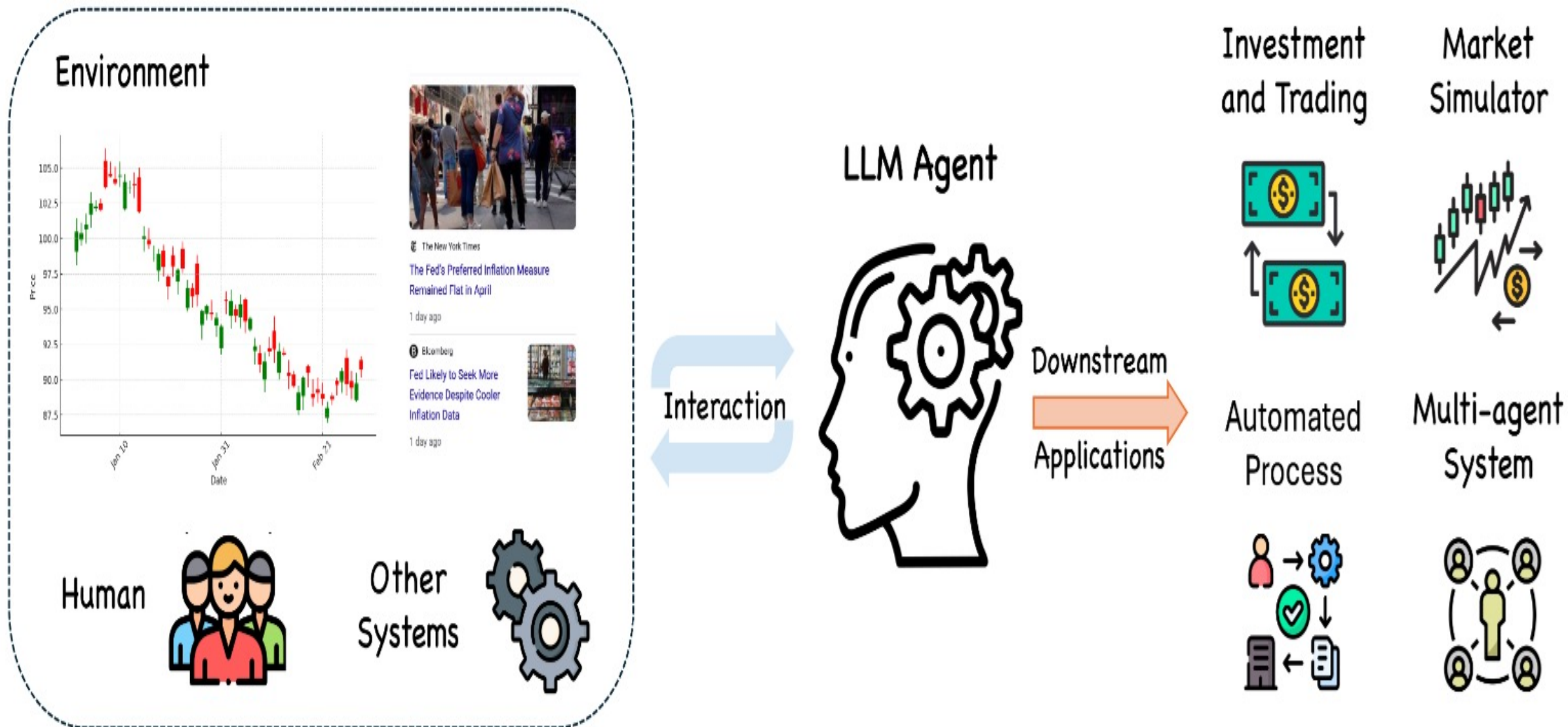

# Digital Sustainability Transformation ESG Data Analytics

**ESG:**

**Environmental**

**Social**

**Governance**

# CSR: Corporate Social Responsibility

# Evolution of Sustainable Finance Research



Source: Kumar, S., Sharma, D., Rao, S., Lim, W. M., & Mangla, S. K. (2022). Past, present, and future of sustainable finance: Insights from big data analytics through machine learning of scholarly research. *Annals of Operations Research*, 1-44.

# Sustainable Development Goals (SDGs)

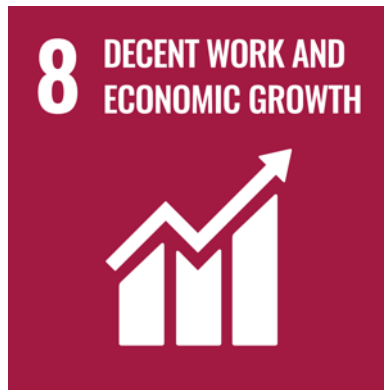

# Sustainable Development Goals (SDGs)

Partnership

Peace

Prosperity

People

Planet



# ESG to 17 SDGs

## ENVIRONMENT



## SOCIAL



## GOVERNANCE



# ESG to 17 SDGs

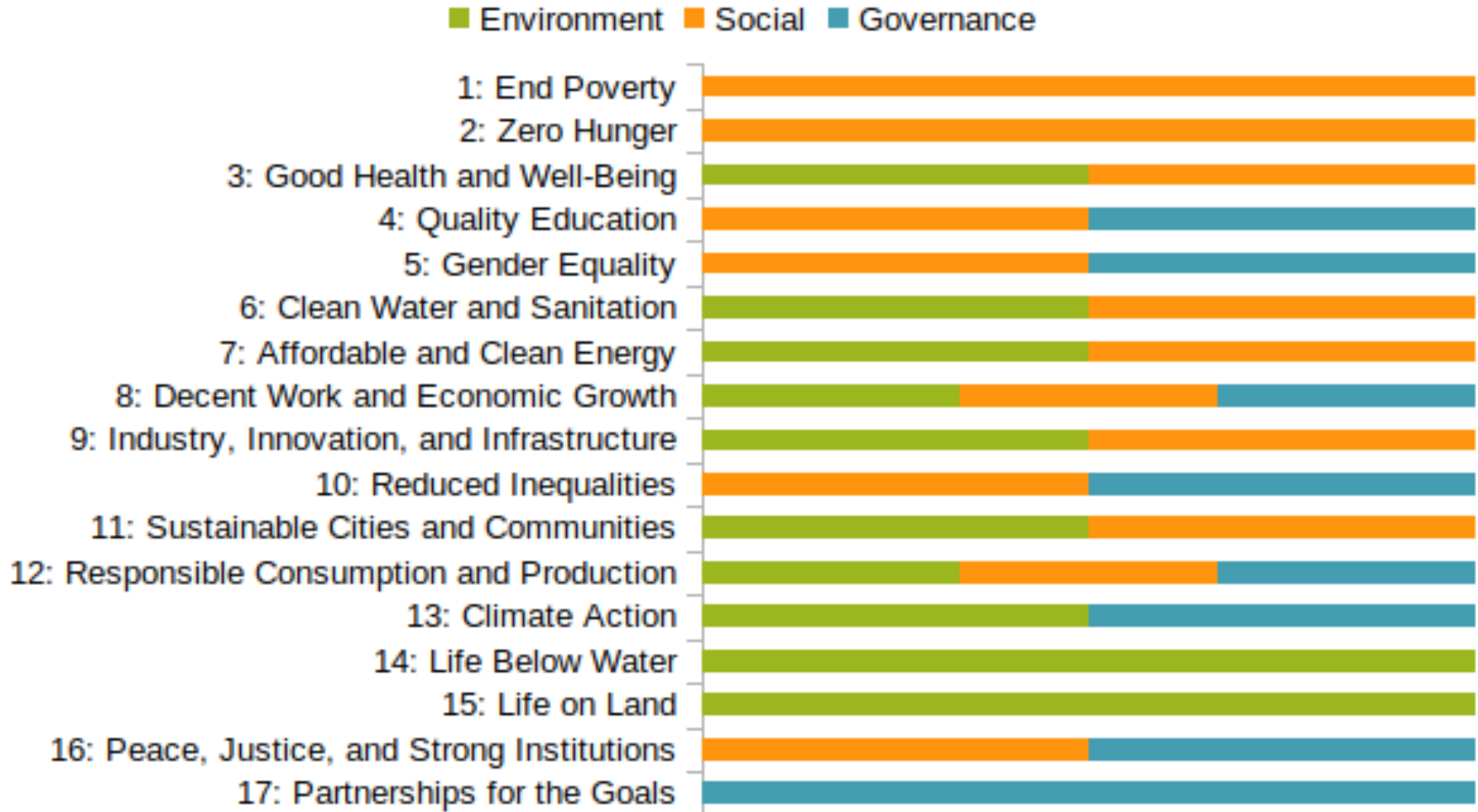

# Net-Zero Transformation

- **Ambition**

- Aligned to achieving global net zero by no later than 2050 & to limit warming to 1.5° C

- **Governance**

- Accountability driven from the top

- **Strategy**

- Embedded and aligned net zero into company strategy

- **Enterprise**

- Key operating model changes in support of transformation

- **Supply chains**

- Transformed net zero supply chains

- **Innovation**

- Developed innovation and technologies to deliver net zero

- **Finance**

- Financing the net zero transformation

- **Transparency**

- Communicating action

- **Engagement**

- Enhancing the pace and scale of net zero action

# Net-Zero Transformation Enablers

## Net-zero industry performance

The four drivers of industry net greenhouse gas (GHG) emissions:

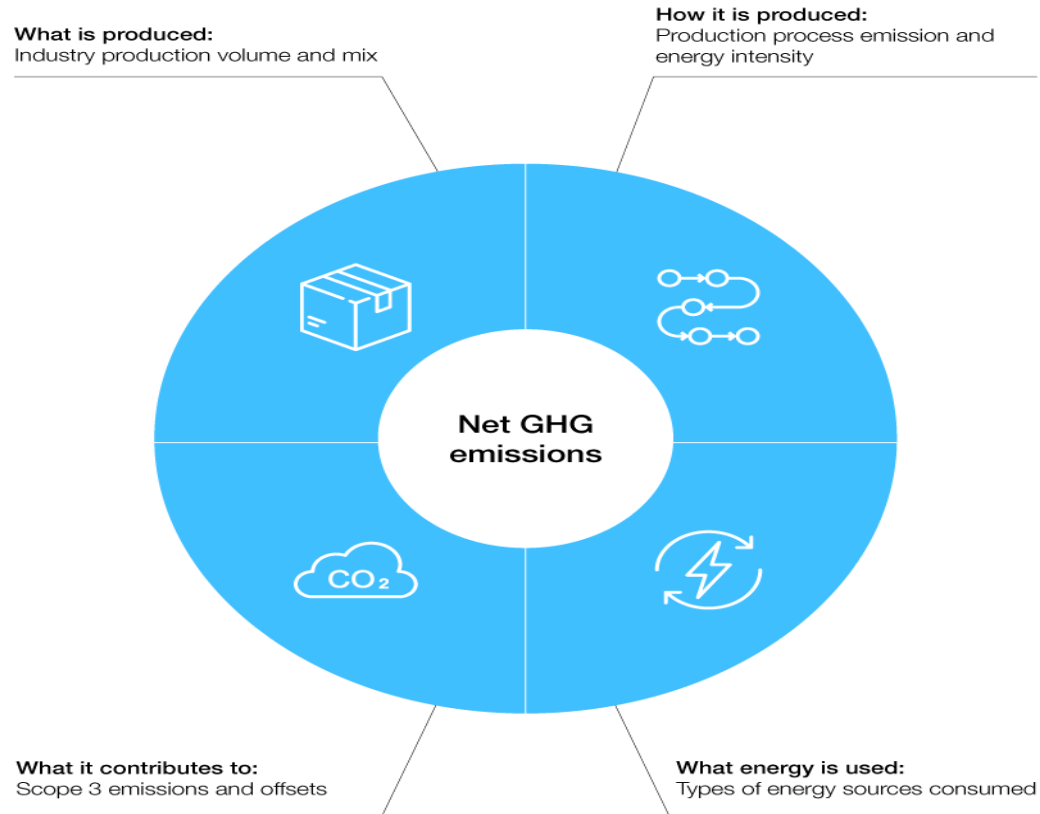

## Net-zero industry readiness

The five enabling dimensions of industry net-zero transformation:

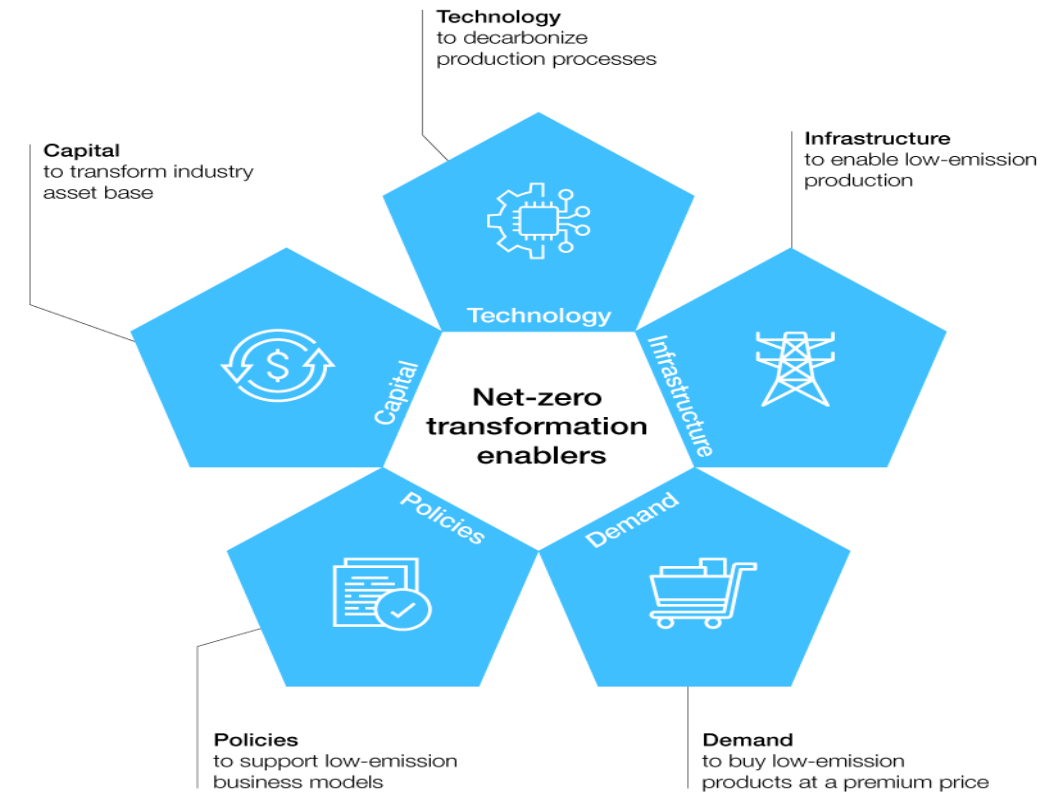

# The Net Zero Transition

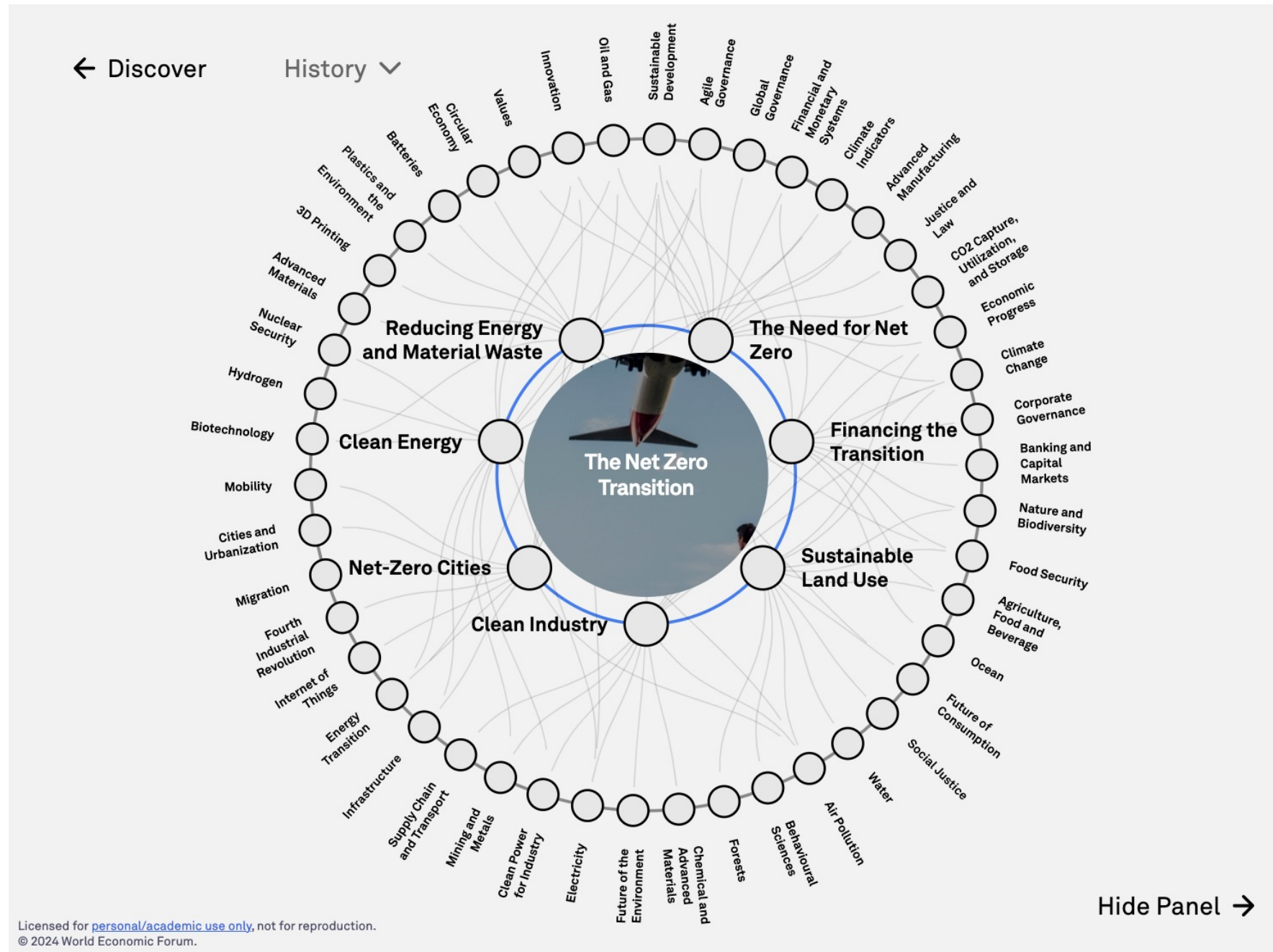

Licensed for [personal/academic use only](#), not for reproduction.  
© 2024 World Economic Forum.

# The Digital Transformation of Business

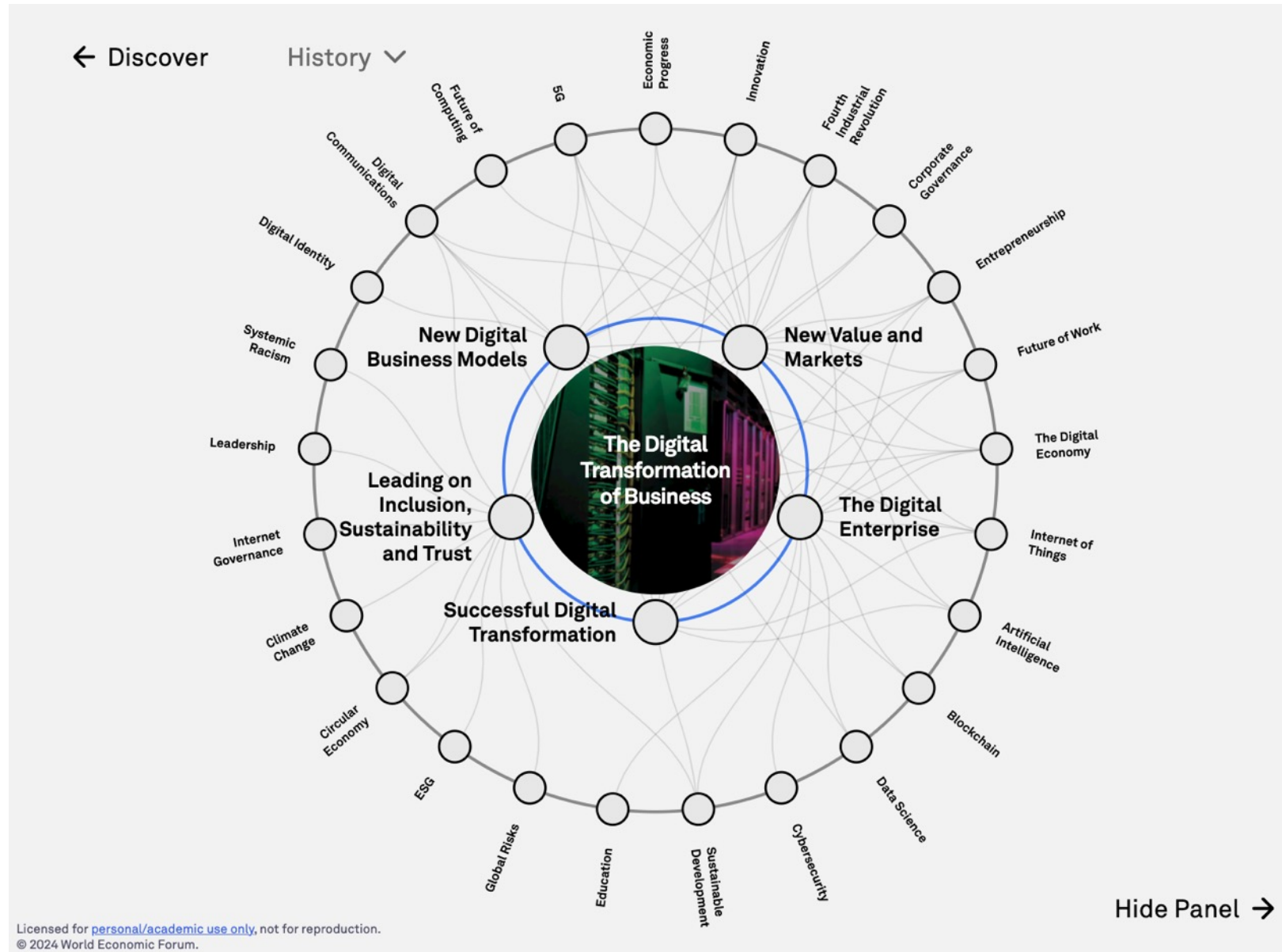

# Digital Transformation

Dimensions	Categories
A. BUSINESS MODELS	<ul style="list-style-type: none"> <li>Business Process Innovation</li> <li>Business Strategy</li> </ul>
B. DIGITAL BUSINESS	<ul style="list-style-type: none"> <li>Digital Culture, Literacy and Skills</li> <li>Digital Economy</li> <li>Innovation and Socio-technical Shared Values</li> </ul>
C. TECHNOLOGIES	<ul style="list-style-type: none"> <li>Technology and Innovation Management</li> <li>Artificial Intelligence</li> <li>Big Data</li> <li>Internet of Things</li> <li>Industry 4.0</li> </ul>
D. SUSTAINABILITY	<ul style="list-style-type: none"> <li>Sustainable Business</li> <li>Sustainable Competitive Advantage</li> <li>Sustainable Development</li> <li>Sustainable Innovation</li> </ul>
E. HUMAN RESOURCES	<ul style="list-style-type: none"> <li>Employee Experience</li> <li>Career Dynamics</li> </ul>
F. SMART CITIES	<ul style="list-style-type: none"> <li>Sustainable Smart Manufacturing</li> <li>Digital Manufacturing</li> </ul>

# Green FinTech Ecosystem

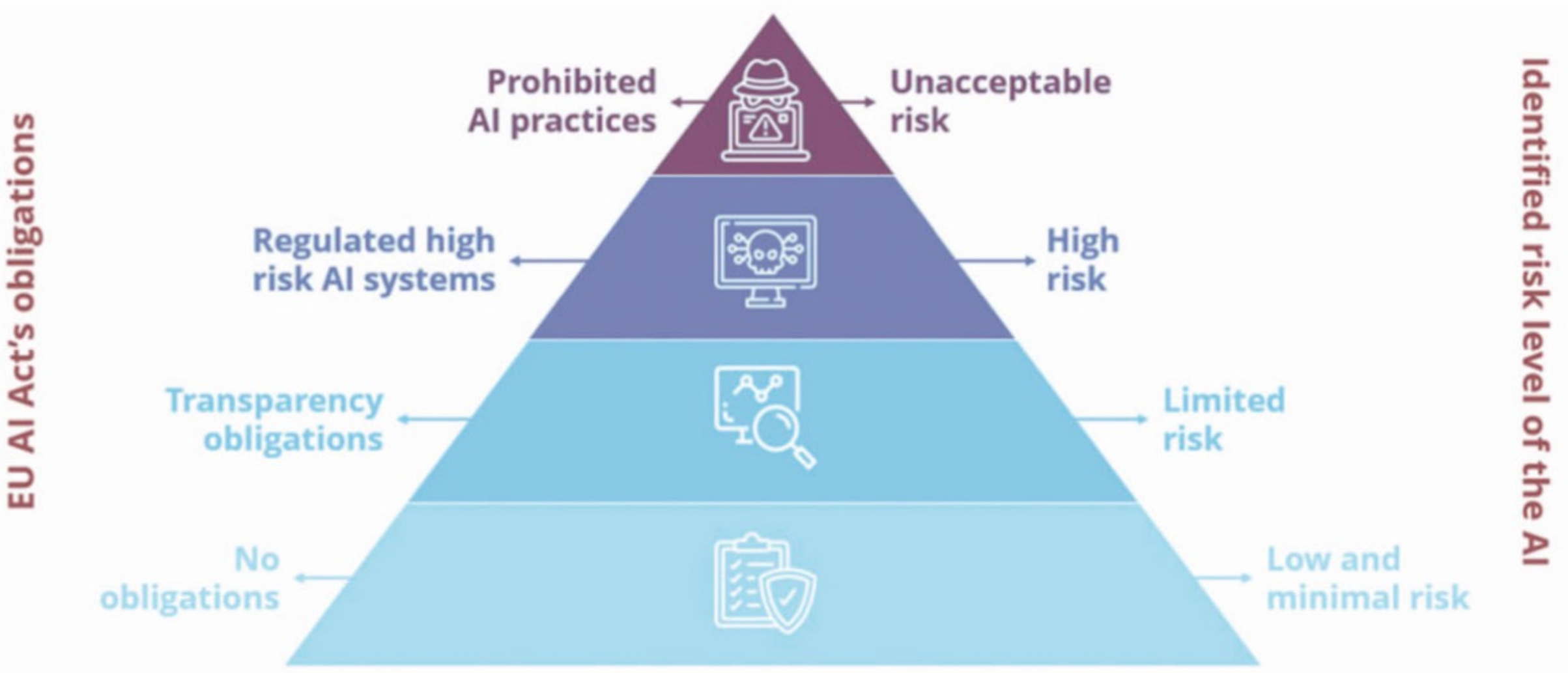

Source: Lee, Haein, Jang Hyun Kim, and Hae Sun Jung. "Deep-learning-based stock market prediction incorporating ESG sentiment and technical indicators." Scientific Reports 14, no. 1 (2024): 10262.

# The EU AI Act Regulatory Framework

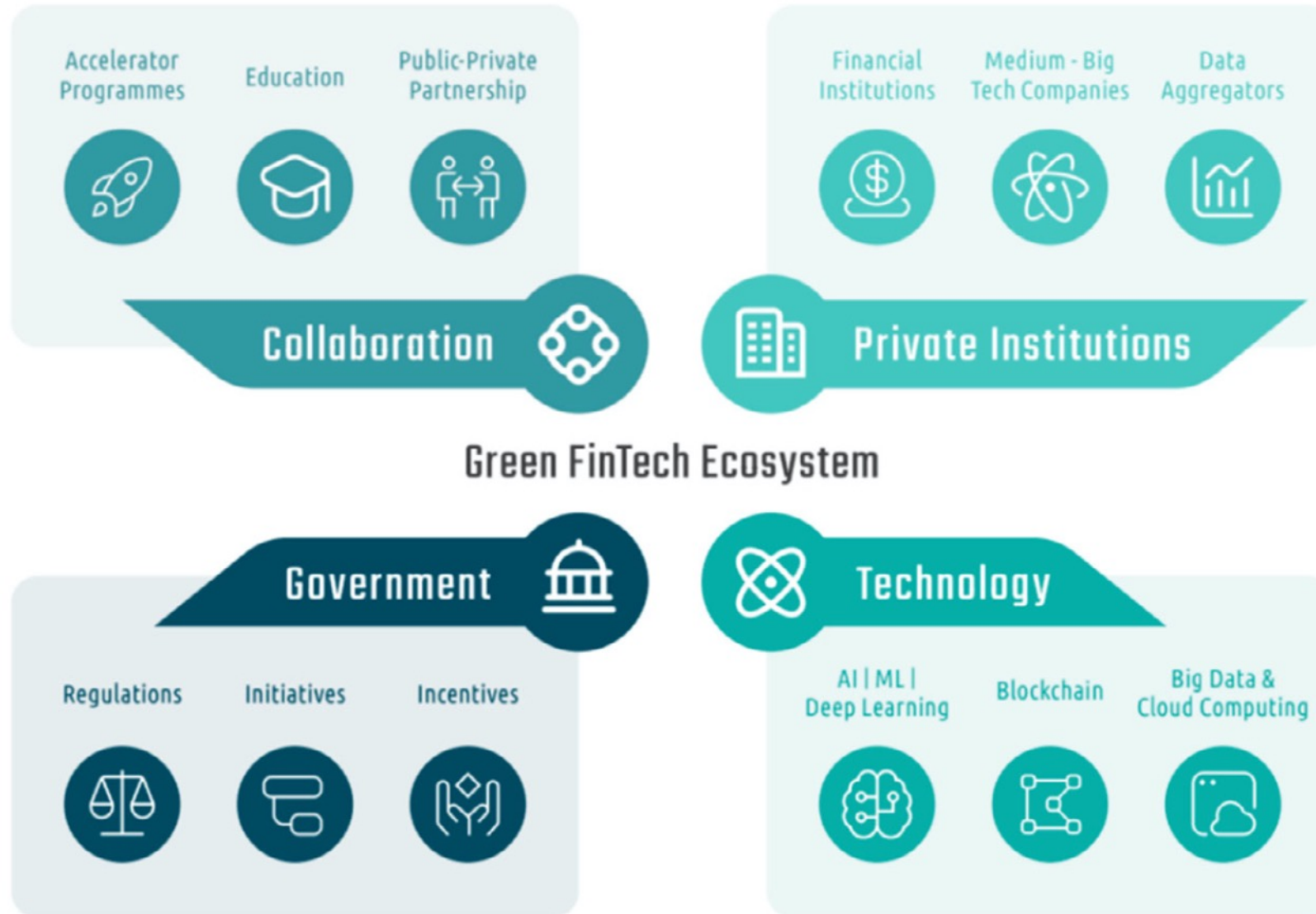

# AI System and ESG World

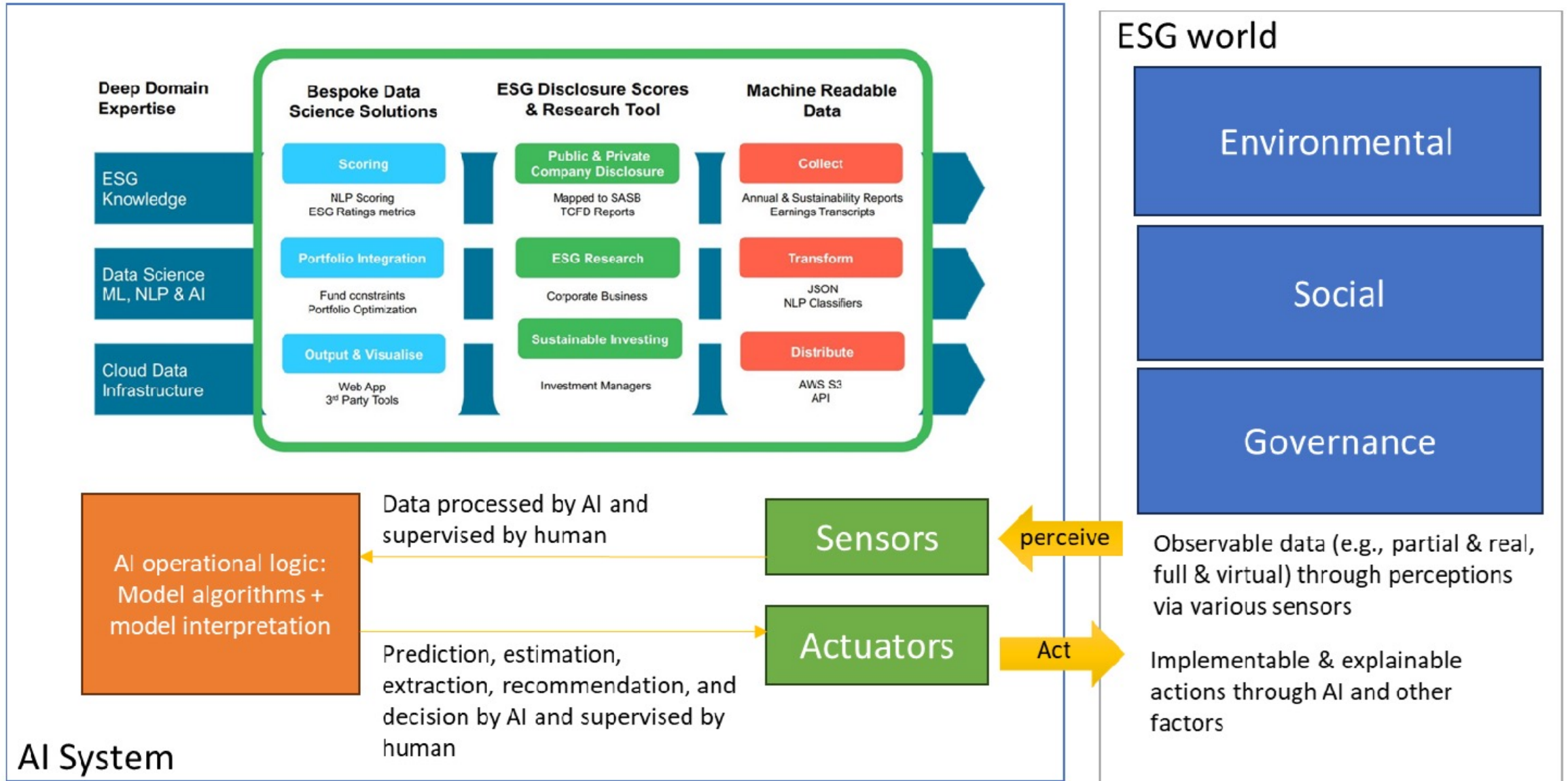

# AI Solution for Net Zero Model

Challenges	Description	Potential AI Solution
Data Complexity and Volume	Handling vast and complex data related to emissions across various industries.	Use of big data analytics and ML to process and analyze large datasets efficiently.
Dynamic Nature of Emissions	Emissions vary over time and by industry, requiring adaptable models. Different scopes may need different approaches.	Development of flexible AI models that can adapt to varying emission patterns and industry-specific factors.
Integration of Diverse Data Sources	Combining data from different sources and sectors for comprehensive analysis.	Implementing AI algorithms capable of integrating and synthesizing diverse data streams for holistic insights.
Predictive Accuracy	Accurately predicting future emissions and the effectiveness of mitigation strategies.	Employing predictive analytics and advanced ML techniques for precise forecasting of emissions and strategy outcomes.
Balancing Economic and Environmental Goals	Ensuring that net zero strategies are economically viable.	AI-driven optimization models that balance economic factors with environmental impact to identify cost-effective sustainability strategies.

# Data Analytics for ESG Ranking & Scoring

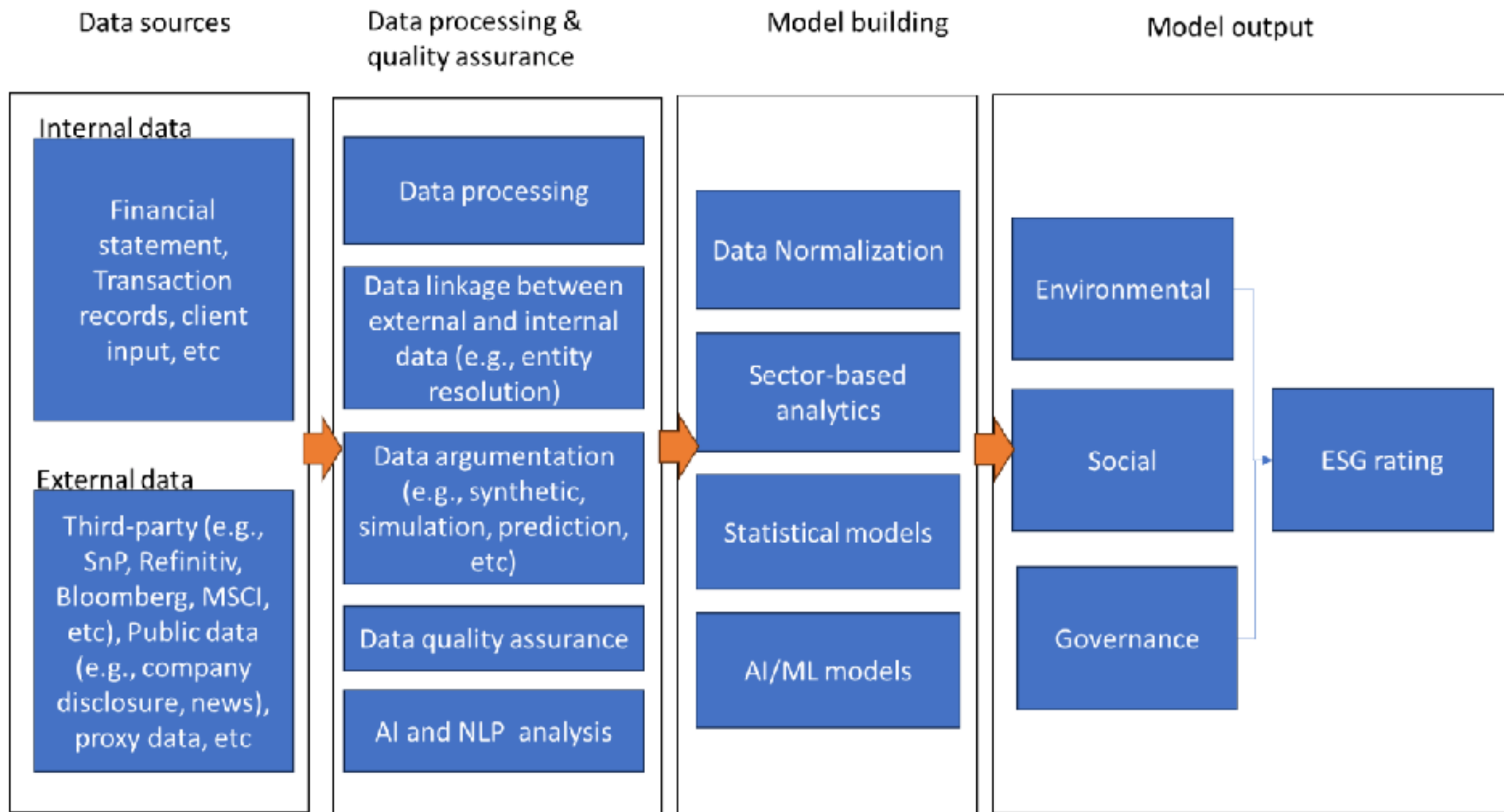

# Traditional and AI-Power ESG Rating

Aspect	Traditional ESG Rating Agencies	AI-Powered ESG Rating Organizations
Data Processing and Analysis	Rely on manual data collection and analysis, subject to human bias, e.g., analyst.	Use algorithms, ML, and NLP to analyze large data sets efficiently, reducing human bias.
Speed and Scalability	Slower due to manual processes; limited in the number of companies assessed. Usually, update semiannually or annually	Faster updates and ability to scale up to assess more companies due to automation. Typically, update in daily or weekly.
Consistency and Objectivity	Potential for inconsistencies and subjective interpretations.	More consistent and objective, though not immune to underlying data biases.
Predictive Insights	Focus on current and past performance based on available data.	Capable of offering predictive insights about future ESG performance and risks.
Customization and Flexibility	Limited customization and flexibility due to manual processes.	Greater customization and flexibility, adapting quickly to new data sources or changing ESG criteria.

# ESG Data Providers

Provider	Description	Website
Bloomberg	Provide global coverage of ESG data; mainly on listed or public companies	<a href="https://finance.com/en/blog/esg/top-5-esg-data-providers-rating-and-report/">https://finance.com/en/blog/esg/top-5-esg-data-providers-rating-and-report/</a>
BvD (Moody's)	Provide ESG ratings, analytics, sustainability ratings, and sustainable finance reviewer/certifier services using data from Moody's. The BvD Orbis users can now add RepRisk's ESG risk metrics to the already substantial arsenal of company information available to you through our flagship global database of more than 200 million private companies	<a href="https://www.bvdinfo.com/en-gb/blog/compliance-and-financial-crime/product-update-using-orbis-to-assess-environmental-social-and-governance-esg-risk">https://www.bvdinfo.com/en-gb/blog/compliance-and-financial-crime/product-update-using-orbis-to-assess-environmental-social-and-governance-esg-risk</a>
CDP	CDP (formerly the Carbon Disclosure Project) ESG Rating is a unique rating that identifies the best ESG-integrated investment funds, based on their ESG performance	<a href="https://www.cdp.net/en/scores/cdp-scores-explained">https://www.cdp.net/en/scores/cdp-scores-explained</a>
FTSE Russell / LSEG	Provide ESG ratings using a company's Theme Exposure and Theme level score assessment to calculate range of assessments that allow investors to understand a company's ESG practices in multiple dimensions.	<a href="https://www.ftserussell.com/products/indices/esg">https://www.ftserussell.com/products/indices/esg</a>
ISS	Provide ESG data and research on companies. The system's goal is to take the ESGY Scorecard directly to the industry level.	<a href="https://www.issgovernance.com/esg/">https://www.issgovernance.com/esg/</a>

# ESG Data Providers

Provider	Description	Website
MSCI	Offer data on ESG. Its ratings aim to measure a company's management of financially relevant ESG risks and opportunities.	<a href="https://www.msci.com/our-solutions/esg-investing/esg-ratings">https://www.msci.com/our-solutions/esg-investing/esg-ratings</a>
Refinitiv / LSEG	Provides comprehensive ESG data. Their ESG scores are designed to transparently and objectively measure a company's relative ESG performance, commitment and effectiveness across 10 main themes (emissions, environmental product innovation, diversity and inclusion, human rights, shareholders, etc.) based on publicly-reported data	<a href="https://www.refinitiv.com/content/dam/marketing/en_us/documents/methodology/refinitiv-esg-scores-methodology.pdf">https://www.refinitiv.com/content/dam/marketing/en_us/documents/methodology/refinitiv-esg-scores-methodology.pdf</a>
Sustainalytics	An independent ESG research and rating agency that provides data and research on the environmental and social performance of companies.	<a href="https://connect.sustainalytics.com/hubfs/SFS/Sustainalytics%20ESG%20Risk%20Rating%20-%20FAQs%20for%20Corporations.pdf">https://connect.sustainalytics.com/hubfs/SFS/Sustainalytics%20ESG%20Risk%20Rating%20-%20FAQs%20for%20Corporations.pdf</a>
S&P Global	Provide access to transparently disclosed ESG data points for companies assessed in the S&P	<a href="https://www.spglobal.com/esg/solutions/esg-data-intelligence">https://www.spglobal.com/esg/solutions/esg-data-intelligence</a>

# ESGReveal:

## LLM for Data Analytics from ESG Reports

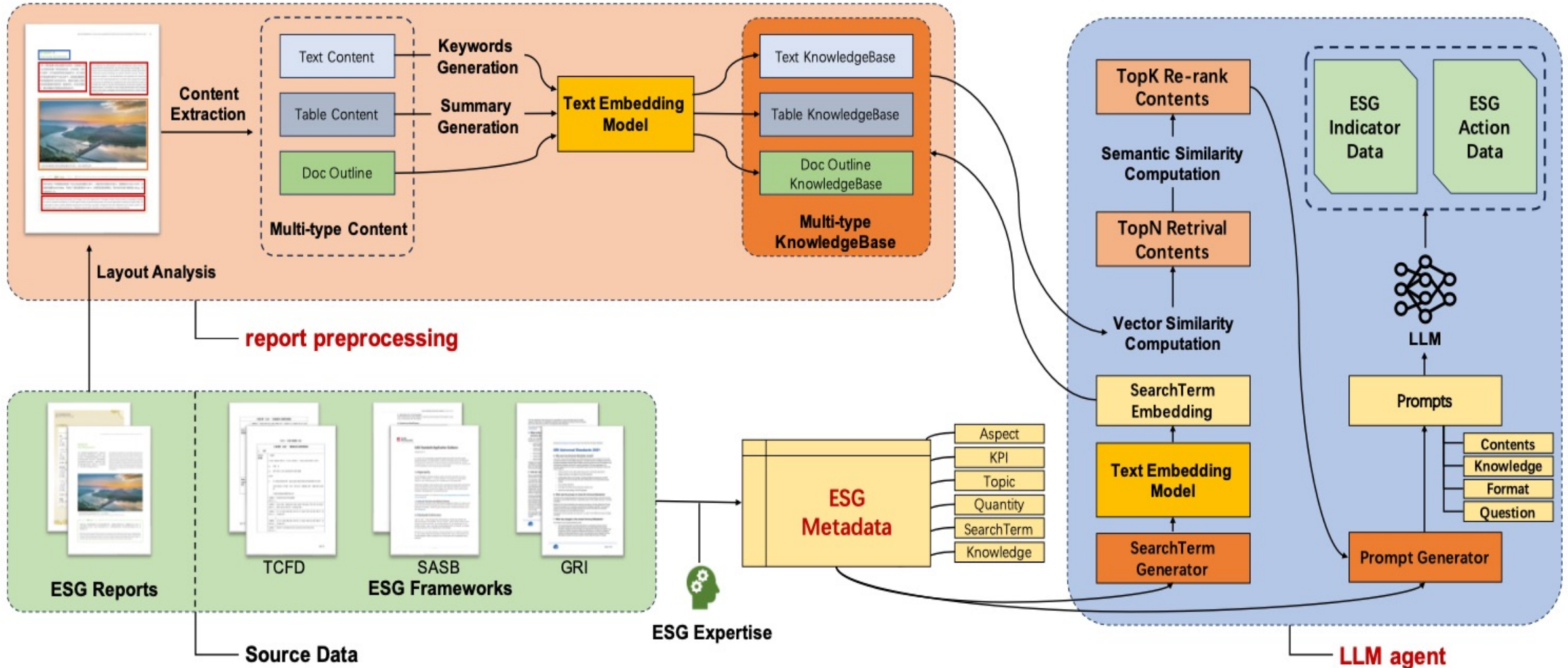

# Structure of ESG Metadata Module: Entities, Extensions, and Expressions

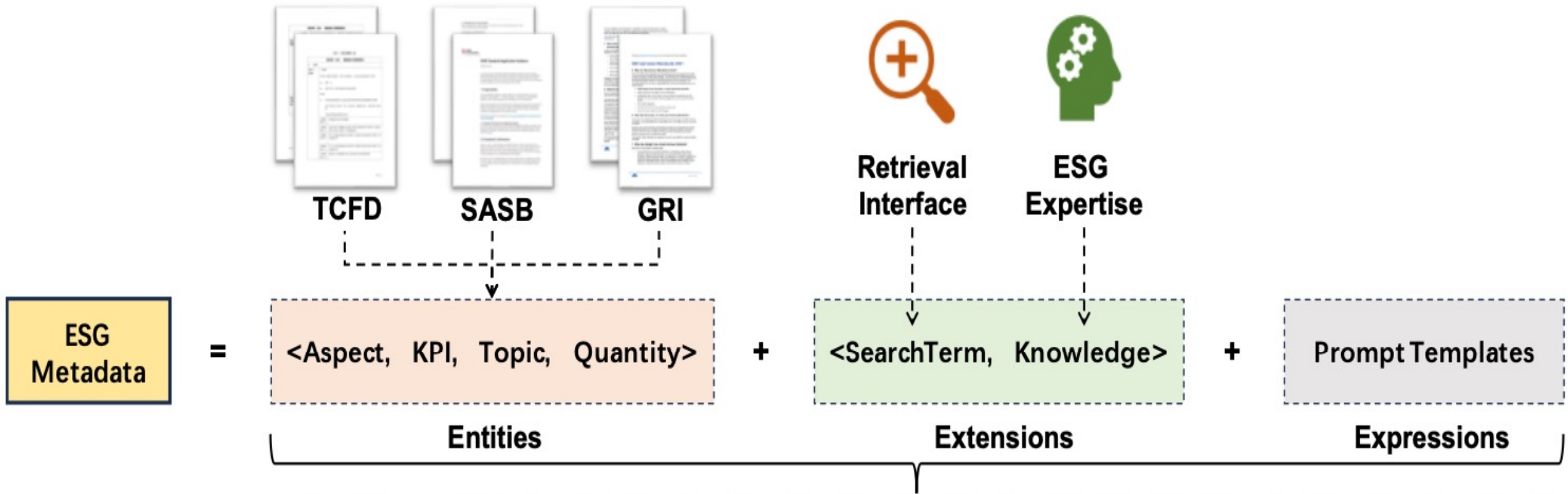

Please use the above information, do not deviate from the given material answer:  
In terms of [Aspect], extract the [KPI] of the last year with [Topic], and give [Quantity]. Return the answer in the following JSON format: {"KPI" : "<KPI>", "Topic" : "<topic>", "value" : "<value>", "Unit" : "<unit>"}

# Information Extraction:

## Unstructured to Structured for ESG Reports

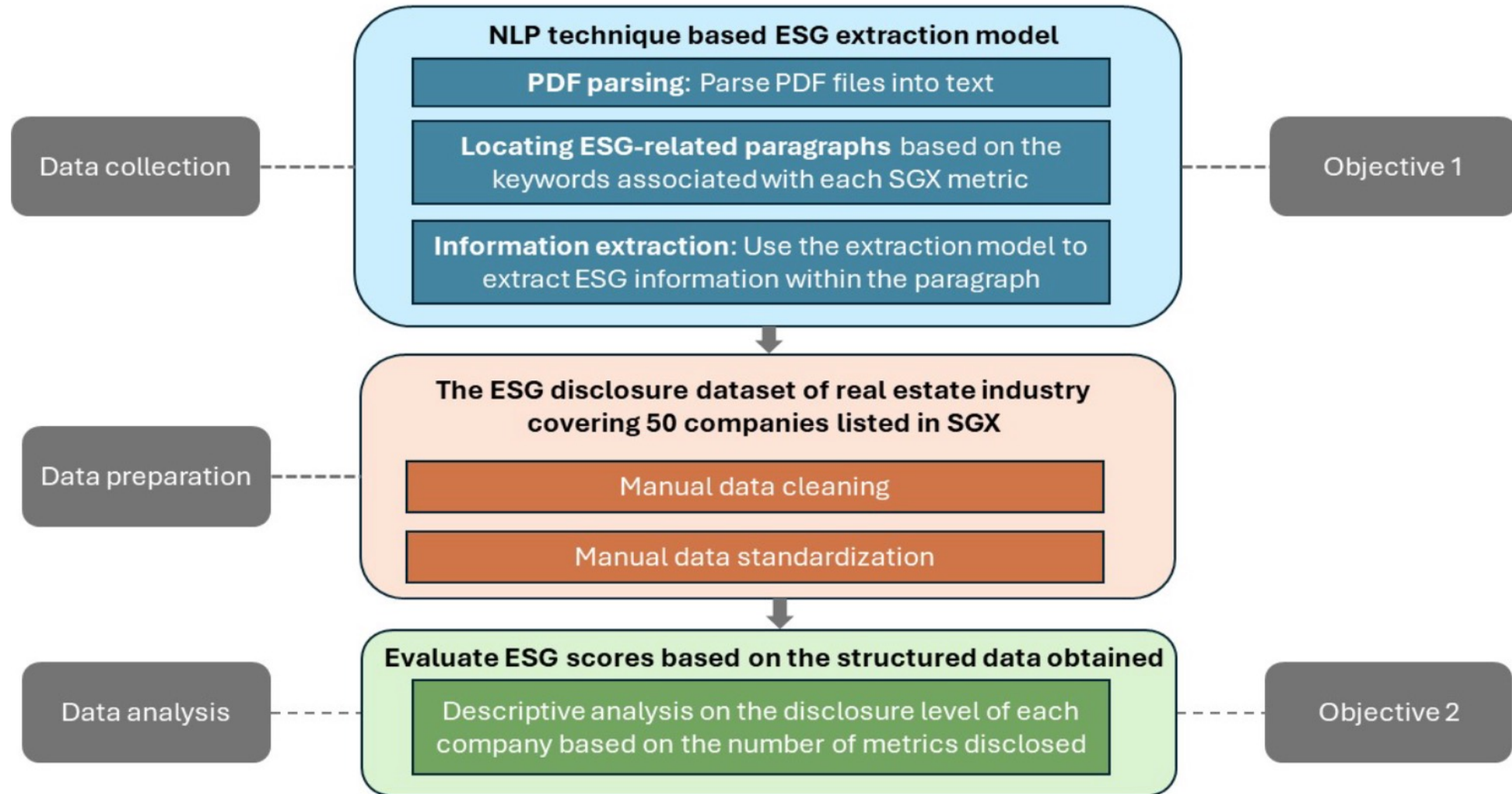

# SGX Suggested ESG Metrics

## Environmental

Total GHG absolute emissions  
GHG Emission intensities  
Total energy consumption  
Energy intensity consumption  
Total water consumption  
Water consumption intensity  
Total waste generated

## Social

Current employees by gender  
New hires by gender  
Turnover by gender  
Current employees by age groups  
New hires by age groups  
Turnover by age groups  
Total turnover  
Total number of employees  
Average training hours per employee  
Average training hours per employee  
by gender  
Fatalities  
High-consequence injuries  
Recordable injuries  
Recordable work-related ill health  
cases

## Governance

Board independence  
Women on the board  
Women in the management team  
Anti-corruption disclosures  
Anti-corruption training for  
employees  
List of relevant certifications  
Alignment with frameworks and  
disclosure practices  
Assurance of sustainability report

# ESG Challenges and Opportunities

- **Challenges**

- **Fragmented and unstructured ESG data.**
- **Lack of standardization and transparency.**
- **Timeliness of data availability.**

- **Opportunities**

- **Rising demand for actionable ESG insights.**
- **Innovation in sustainable solutions and policies.**
- **Generative AI as a tool for transformation.**

# Sustainability and ESG Data Analytics



# Generative AI for ESG Data Analytics

- **Data Integration and Enrichment:**
  - Synthesizing structured and unstructured ESG data.
- **Automated Reporting and Insight Generation:**
  - Tailored ESG reports and insights for stakeholders.
- **Scenario Modeling and Forecasting:**
  - Simulating potential risks and opportunities.
- **Addressing Bias and Ensuring Accountability:**
  - Transparent, fair, and ethical AI deployment.

# Generative AI and LLMs for Sustainability and ESG Data Analytics



# Sustainability Innovation with Generative AI

- **Sustainable Product Design:**
  - Eco-friendly designs minimizing waste and energy.
- **Policy Formulation and Implementation:**
  - AI-driven simulations for effective policies.
- **Stakeholder Engagement and Awareness:**
  - Communicating ESG strategies with compelling AI-driven visuals.



# Mapping the ESG Standards Landscape

- **The most prevalent ESG reporting frameworks**
  - **GRI (Global Report Initiative)**
  - **CDP (Carbon Disclosure Project)**
  - **SASB (Sustainability Accounting Standards Board)**
  - **ISSB (International Sustainability Standards Board)**
  - **TCFD (Task Force on Climate-related Financial Disclosures)**
- **How companies choose**
  - **Materiality, industry-specific standards, investor alignment**

# GRI (Global Report Initiative)



Standards ▾

How to use the GRI Standards ▾

Reporting support ▾

Public policy & partnerships ▾

About GRI ▾

News ▾

Goals and targets database

Sign In

Search 🔍

Donate Now



## The global leader for impact reporting

Welcome to GRI. For over 25 years, we have developed and delivered the global best practice for how organizations communicate and demonstrate accountability for their impacts on the environment, economy and people.

We provide the world's most widely used sustainability reporting standards, which cover topics that range from biodiversity to tax, waste to emissions, diversity and equality to health and safety. As such, GRI reporting is the enabler for transparency and dialogue between companies and their stakeholders.

[Access the GRI Standards →](#)

Feedback

# CDP (Carbon Disclosure Project)



[Guidance & questionnaires](#) [Contact](#) [Regional websites](#) ▾ [Language](#) ▾

[About us](#) [Our work](#) [Why disclose?](#) [Become a member](#) [Data and insights](#)

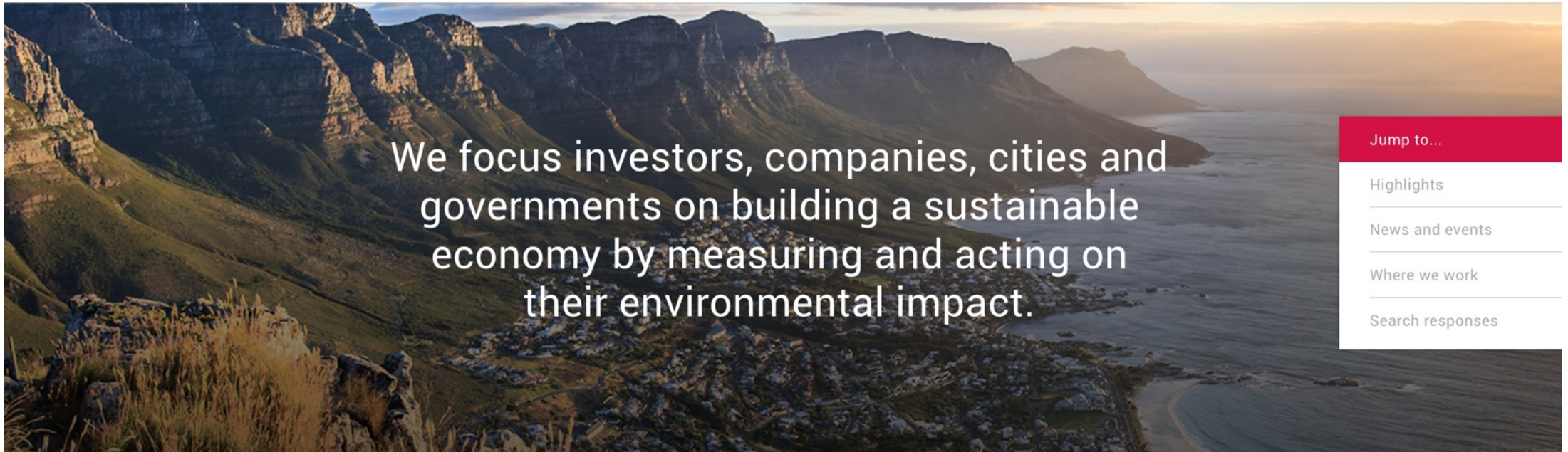
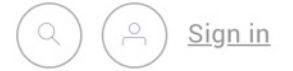

We focus investors, companies, cities and governments on building a sustainable economy by measuring and acting on their environmental impact.

Jump to...

- Highlights
- News and events
- Where we work
- Search responses

CDP is a not-for-profit charity that runs the global disclosure system for [investors](#), [companies](#), [cities](#), [states and regions](#) to manage their environmental impacts. Over the past 20 years we have created a system that has resulted in unparalleled engagement on environmental issues worldwide. Find out more about [how we work](#).

<https://www.cdp.net/>

# SASB (Sustainability Accounting Standards Board)

IFRS Foundation

Other Resources: [The ISSB](#) [Integrated Reporting Framework](#)



[✉ Subscribe](#) [↓ Download Standards](#)

[About](#) [SASB Standards](#) [Using the SASB Standards](#) [Pathway to ISSB](#) [Education](#) [Membership](#)

An aerial photograph of a landscape featuring a winding river through green fields and a dense forest of trees with some autumn-colored foliage.

**SASB Standards: Your pathway to ISSB**

[Learn more](#)

<https://sasb.org/>

# ISSB (International Sustainability Standards Board)



ABOUT US | IFRS ACCOUNTING | IFRS SUSTAINABILITY

Home > International Sustainability Standards Board

## International Sustainability Standards Board

ABOUT

MEMBERS

MEETINGS

RESOURCES

NEWS

### About the International Sustainability Standards Board

The Trustees of the IFRS Foundation announced the formation of the International Sustainability Standards Board (ISSB) on 3 November 2021 at COP26 in Glasgow, following strong market demand for its establishment. The ISSB is developing—in the public interest—standards that will result in a high-quality, comprehensive global baseline of sustainability disclosures focused on the needs of investors and the financial markets.

Sustainability factors are becoming a mainstream part of investment decision-making. There are increasing calls for companies to provide high-quality, globally comparable information on sustainability-related risks and opportunities, as indicated by feedback from many consultations with market

#### Related information

[Sustainability FAQs](#)

[General Sustainability-related Disclosures project](#)

[Climate-related Disclosures project](#)

[Consolidated organisations](#)

<https://www.ifrs.org/groups/international-sustainability-standards-board/>

# TCFD

## (Task Force on Climate-related Financial Disclosures)



<https://www.ifrs.org/sustainability/tcf/>



ABOUT US | IFRS ACCOUNTING | IFRS SUSTAINABILITY

Home > ISSB and TCFD

### ISSB and TCFD

The Financial Stability Board has announced that the work of the TCFD has been completed, with the ISSB's Standards marking the '**culmination of the work of the TCFD**'.

Companies applying IFRS S1 *General Requirements for Disclosure of Sustainability-related Financial Information* and IFRS S2 *Climate-related Disclosures* will meet the TCFD recommendations as the recommendations are fully incorporated into the ISSB's Standards.

Companies can continue to use the **TCFD recommendations** should they choose to do so, and some companies may still be required to use the TCFD recommendations. Using the recommendations is a good entry point for companies as they move to use the ISSB's Standards.

The IFRS Foundation has **published a comparison** of the requirements in IFRS S2 and the TCFD recommendations.

#### Related Information

[IFRS Foundation welcomes culmination of TCFD work and transfer of TCFD monitoring responsibilities to ISSB from 2024](#)

[Comparison: IFRS S2 Climate-related Disclosures with the TCFD Recommendations](#)

[Resource: Making the transition from TCFD to ISSB](#)

[IFRS Sustainability Standards Navigator](#)

<https://www.fsb-tcf.org/>

# Sustainable Productivity: Finance ESG

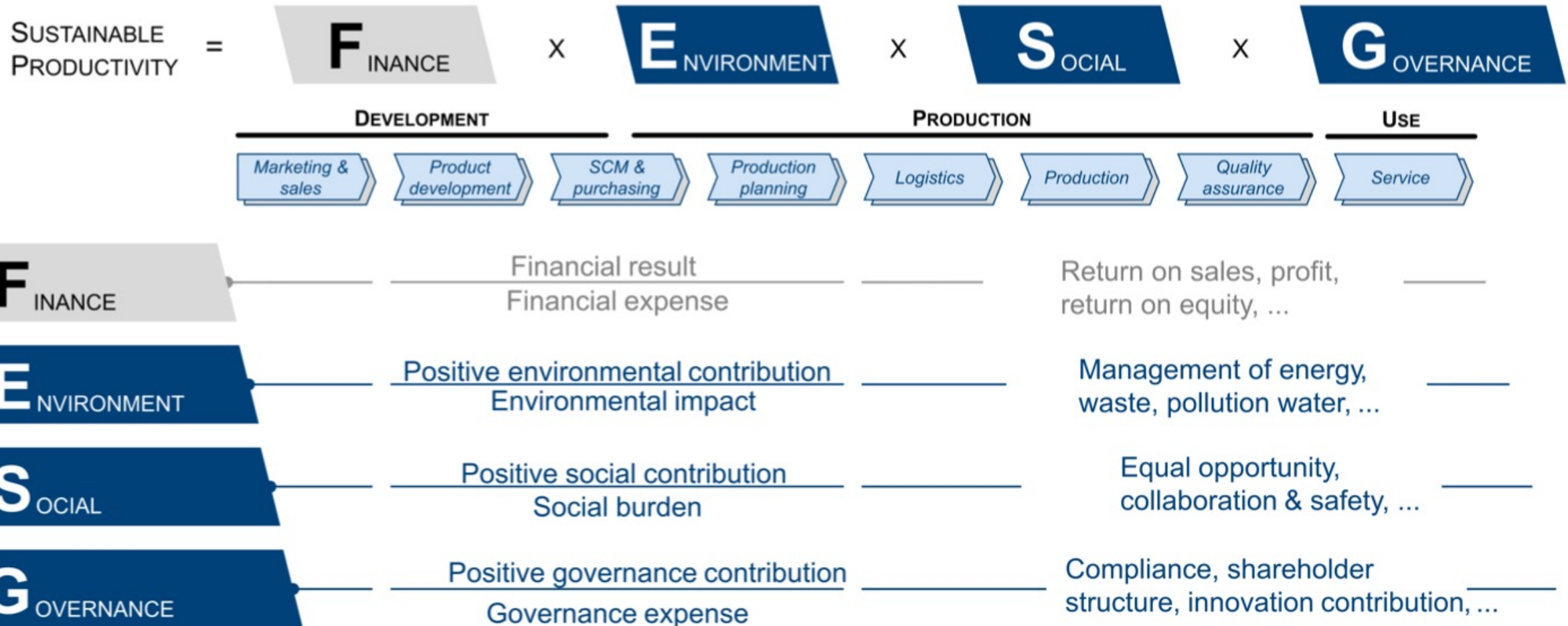

# Sustainable Resilient Manufacturing

## ESG

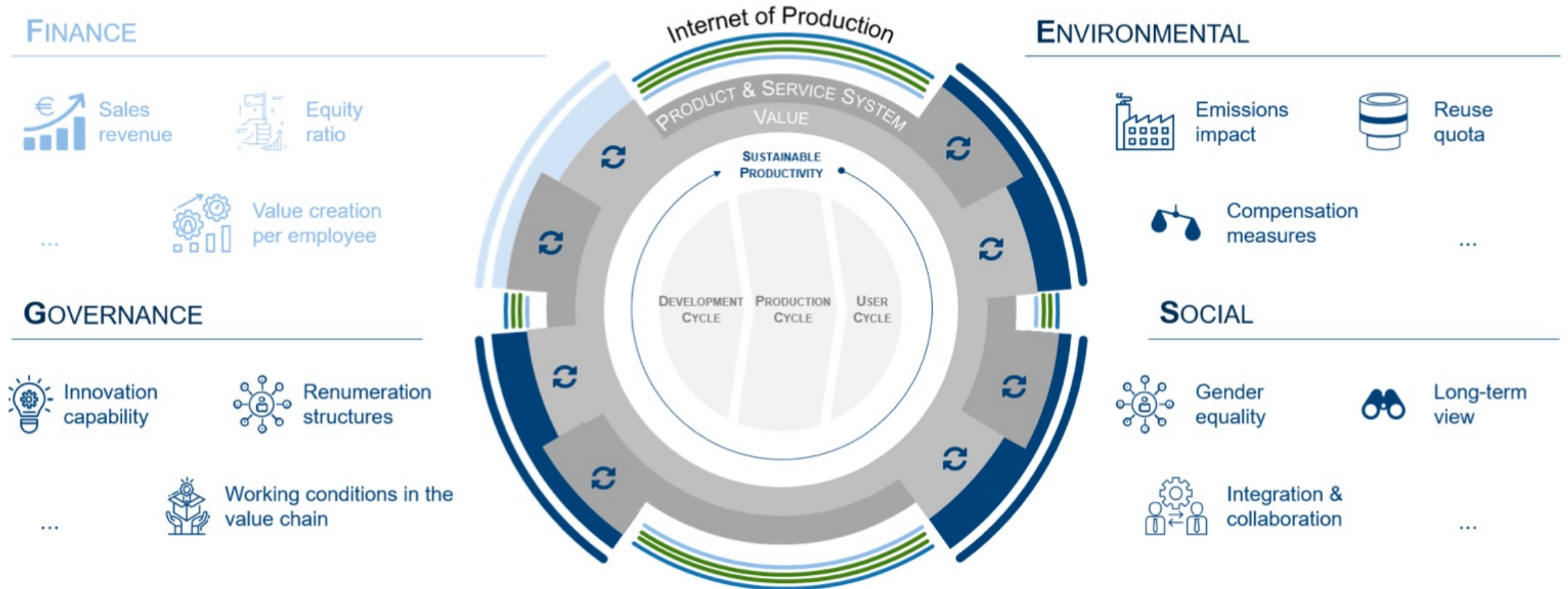

# ESG Indexes

- **MSCI ESG Index**
- **Dow Jones Sustainability Indices (DJSI)**
- **FTSE ESG Index**

# MSCI ESG Rating Framework

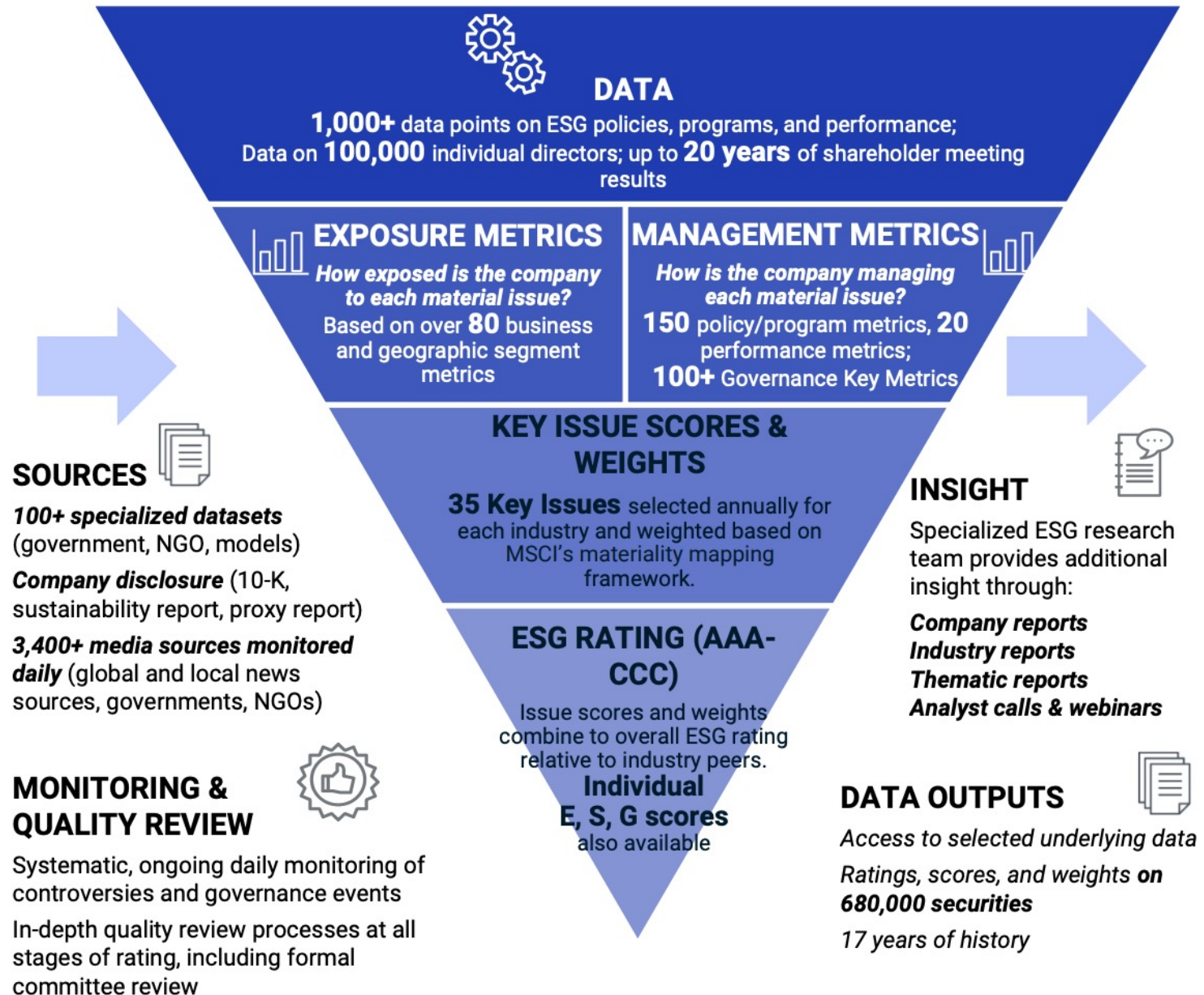

# MSCI ESG Key Issue Hierarchy

3 Pillars	10 Themes	35 ESG Key Issues	
<b>Environment</b>	<b>Climate Change</b>	Carbon Emissions Product Carbon Footprint	Financing Environmental Impact Climate Change Vulnerability
	<b>Natural Capital</b>	Water Stress Biodiversity & Land Use	Raw Material Sourcing
	<b>Pollution &amp; Waste</b>	Toxic Emissions & Waste Packaging Material & Waste	Electronic Waste
	<b>Environmental Opportunities</b>	Opportunities in Clean Tech Opportunities in Green Building	Opportunities in Renewable Energy
<b>Social</b>	<b>Human Capital</b>	Labor Management Health & Safety	Human Capital Development Supply Chain Labor Standards
	<b>Product Liability</b>	Product Safety & Quality Chemical Safety Consumer Financial Protection	Privacy & Data Security Responsible Investment Health & Demographic Risk
	<b>Stakeholder Opposition</b>	Controversial Sourcing Community Relations	
	<b>Social Opportunities</b>	Access to Communications Access to Finance	Access to Health Care Opportunities in Nutrition & Health
<b>Governance</b>	<b>Corporate Governance</b>	Ownership & Control Board	Pay Accounting
	<b>Corporate Behavior</b>	Business Ethics Tax Transparency	

# MSCI Governance Model Structure

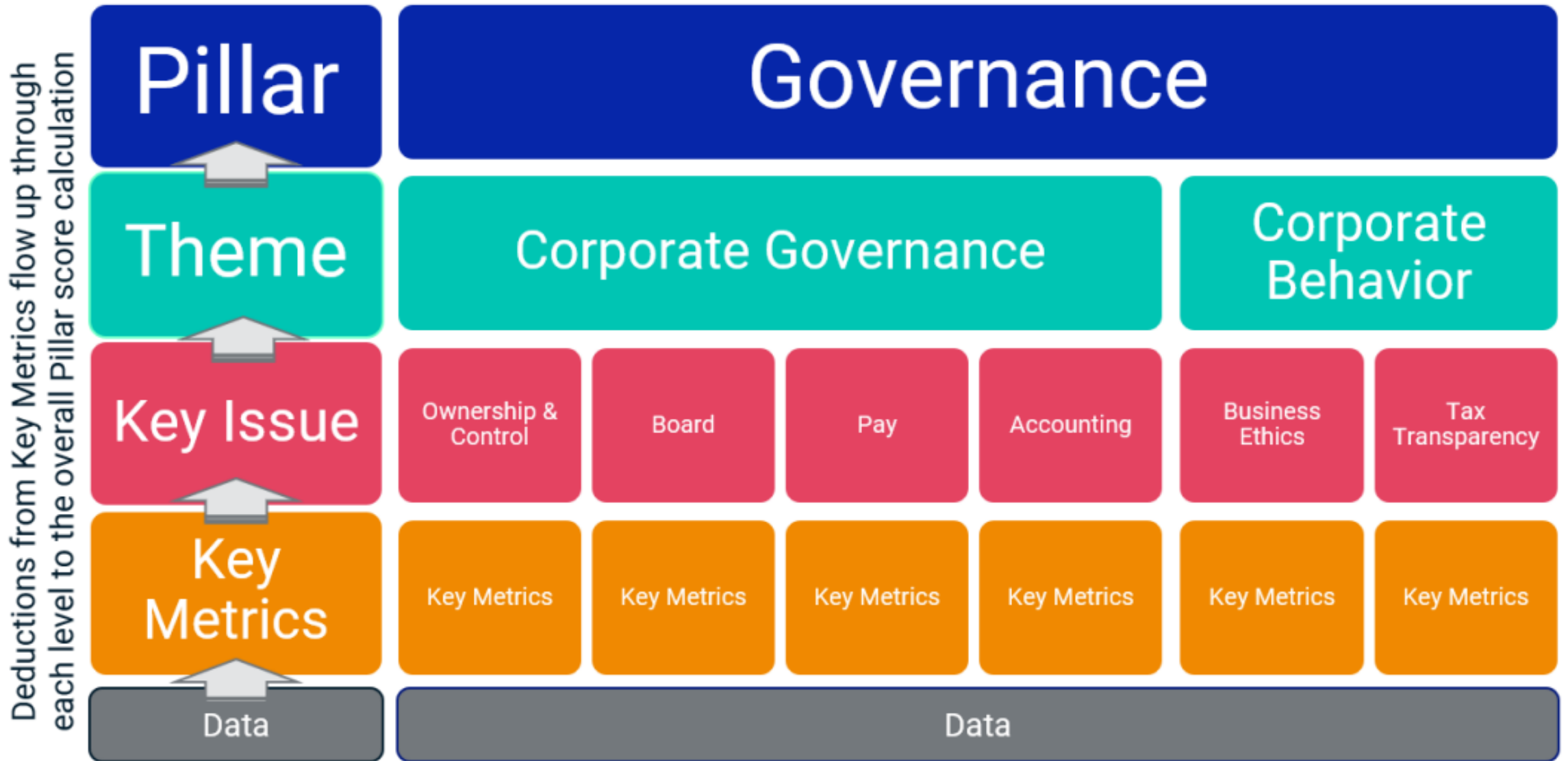

# MSCI Hierarchy of ESG Scores

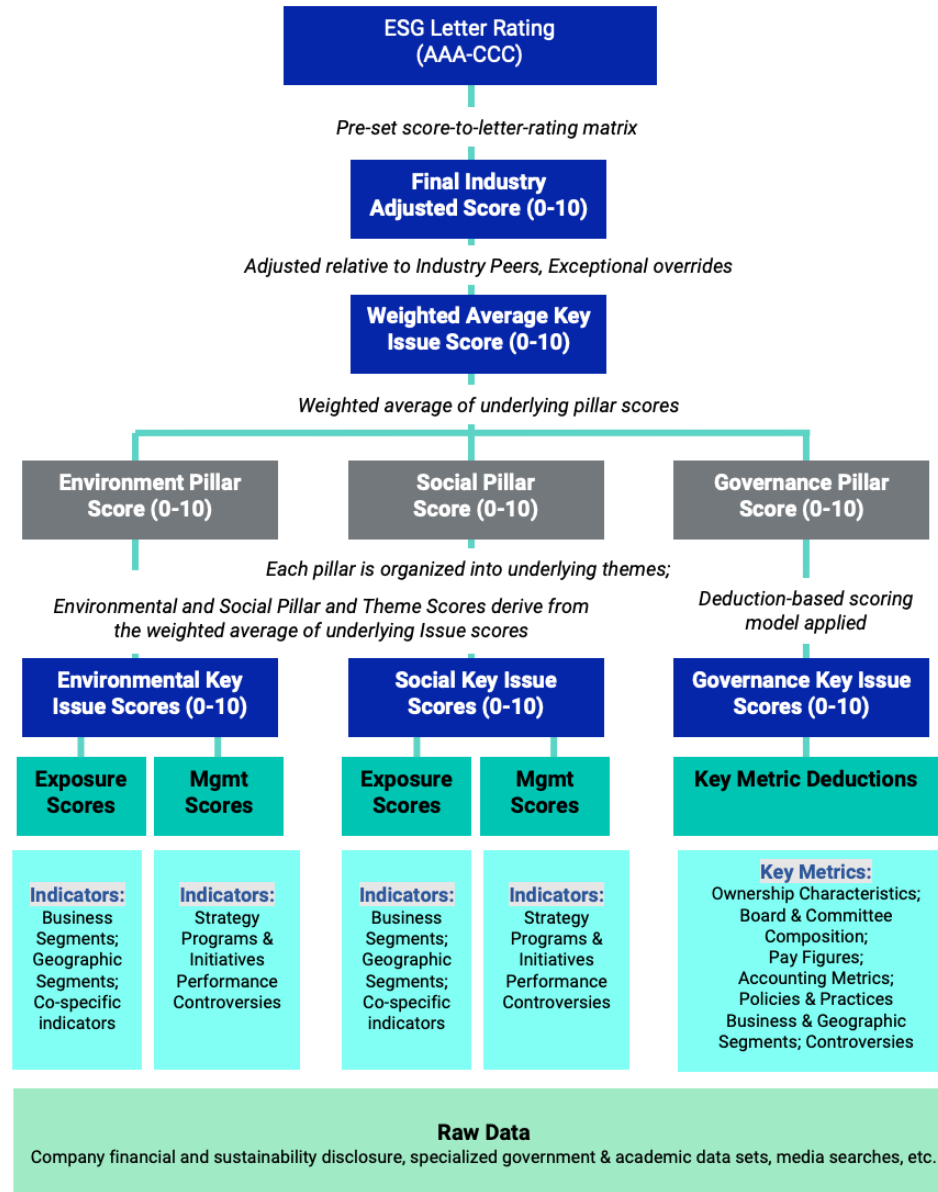

# DJSI S&P Global ESG Score

**8,000**  
Companies

**90%**  
Global market capitalization

**340,000+**  
Current Research Universe and Active Securities

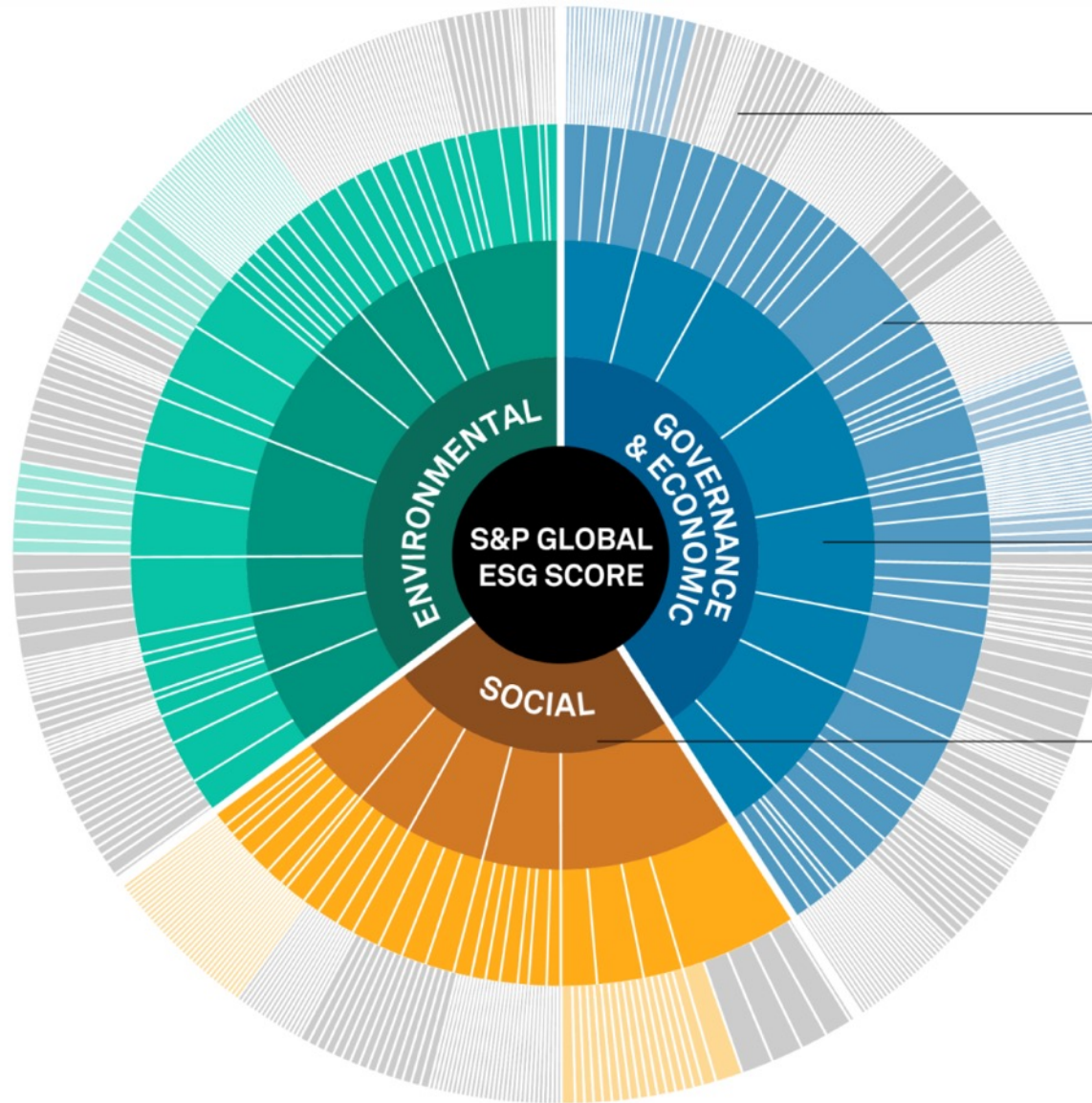

Approx.  
**1,000**  
Datapoints

**Assessed values, text, checkboxes, documents**  
Sources: Web-based questionnaire and company documents

**130+**  
Questions

**Weighted data point scores**  
Up to 50% industry-specific

Ave.  
**30+**  
Criteria scores

**Weighted question scores**  
61 industry specific approaches, with tailored questions, criteria and related weightings

**3**  
Dimension scores

**Weighted criteria scores**  
Adjusted for corporate ESG controversies where applicable

**1**  
S&P Global ESG Score

**Sum of weighted dimension scores**

# FTSE Russell ESG Ratings



# Sustainalytics

## ESG Risk Ratings

Analyst-based  
approach

Sustainalytics' ESG Risk Ratings measure a company's exposure to industry-specific material ESG risks and how well a company is managing those risks.

Negligible	Low	Medium	High	Severe
0 - 10	10 - 20	20 - 30	30 - 40	40+

# Truvalue ESG Ranks

Machine-based  
approach

- **Truvalue Labs** applies **AI** to analyze over **100,000 sources** and uncover **ESG risks** and opportunities hidden in **unstructured text**.
- The ESG Ranks data service produces an overall company rank based on industry percentile leveraging the **26 ESG categories** defined by the **Sustainability Accounting Standards Board (SASB)**.
- The data feed covers 20,000+ companies with more than 13 years of history.

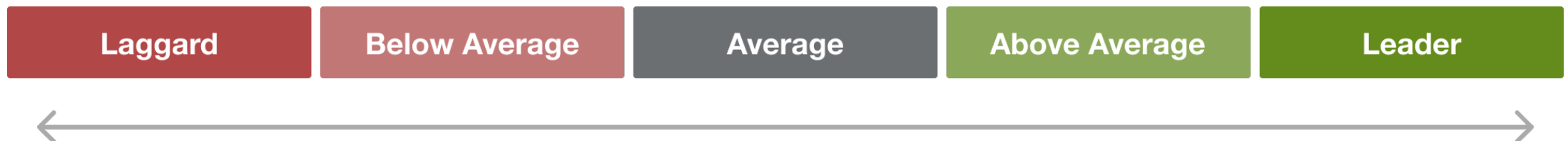

# Analyst-driven vs. AI-driven ESG

## Analyst-driven ESG research

Derives ratings in a structured data model

## Sustainalytics



*Analyst role at the end of the process allows subjectivity to color results*

## AI-driven ESG research

Derives signals from unstructured data

## Truvalue Labs



*Analyst expertise at the beginning of the process produces consistent results*

# Analyst based ESG Research

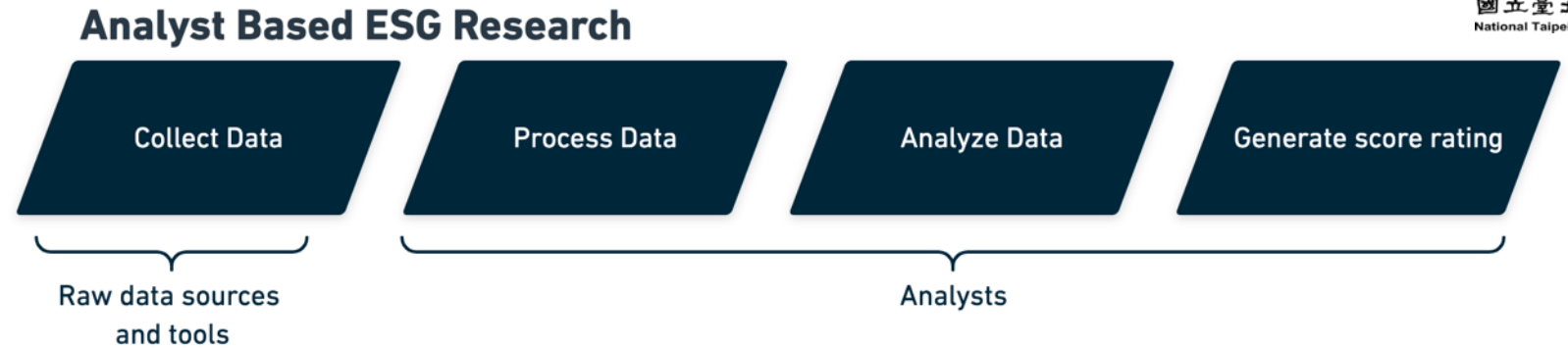

# AI based ESG Research

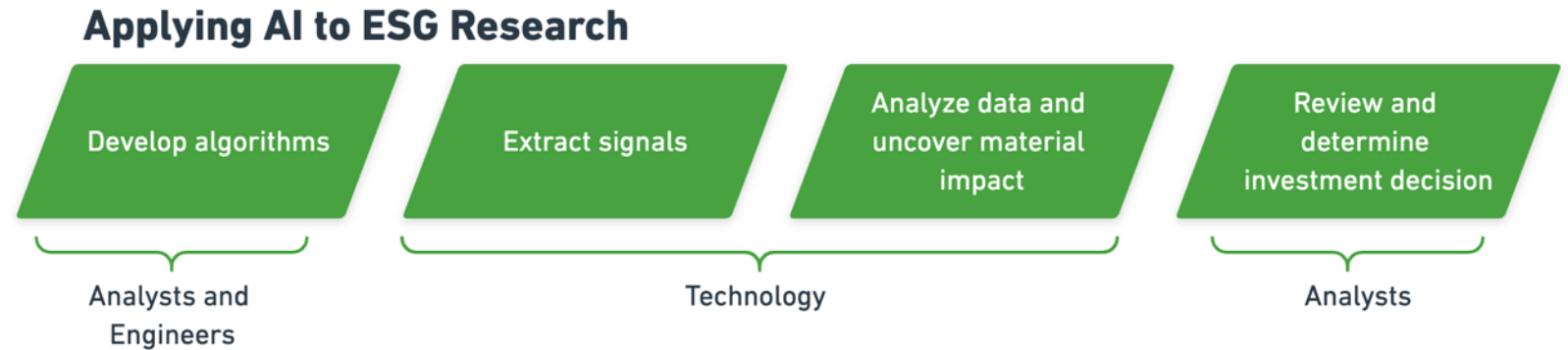

**It would take an analyst over 5 years to do what our AI can in 1 week**

Combining analysts with AI creates gives you the full picture

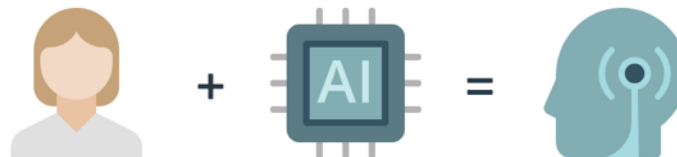

**ESG ANALYTICS**  
Invest where it matters.

# ESG Analytics: NLP Taxonomy

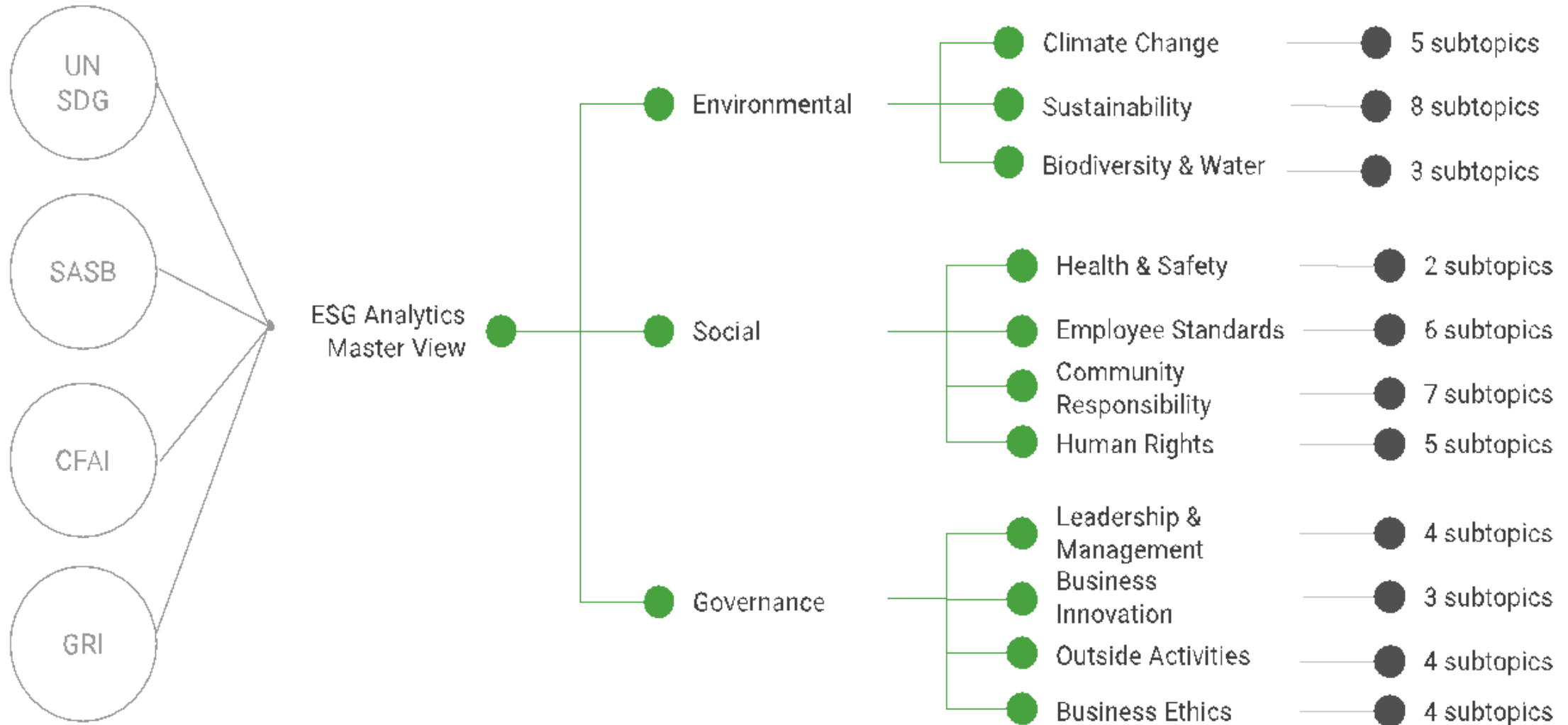

# Top ESG Reporting Software

**Environmental, Social and Governance (ESG) Reporting software or Sustainability software helps organizations manage their operational data, evaluate their impact on the environment and provide reporting to perform audits.**

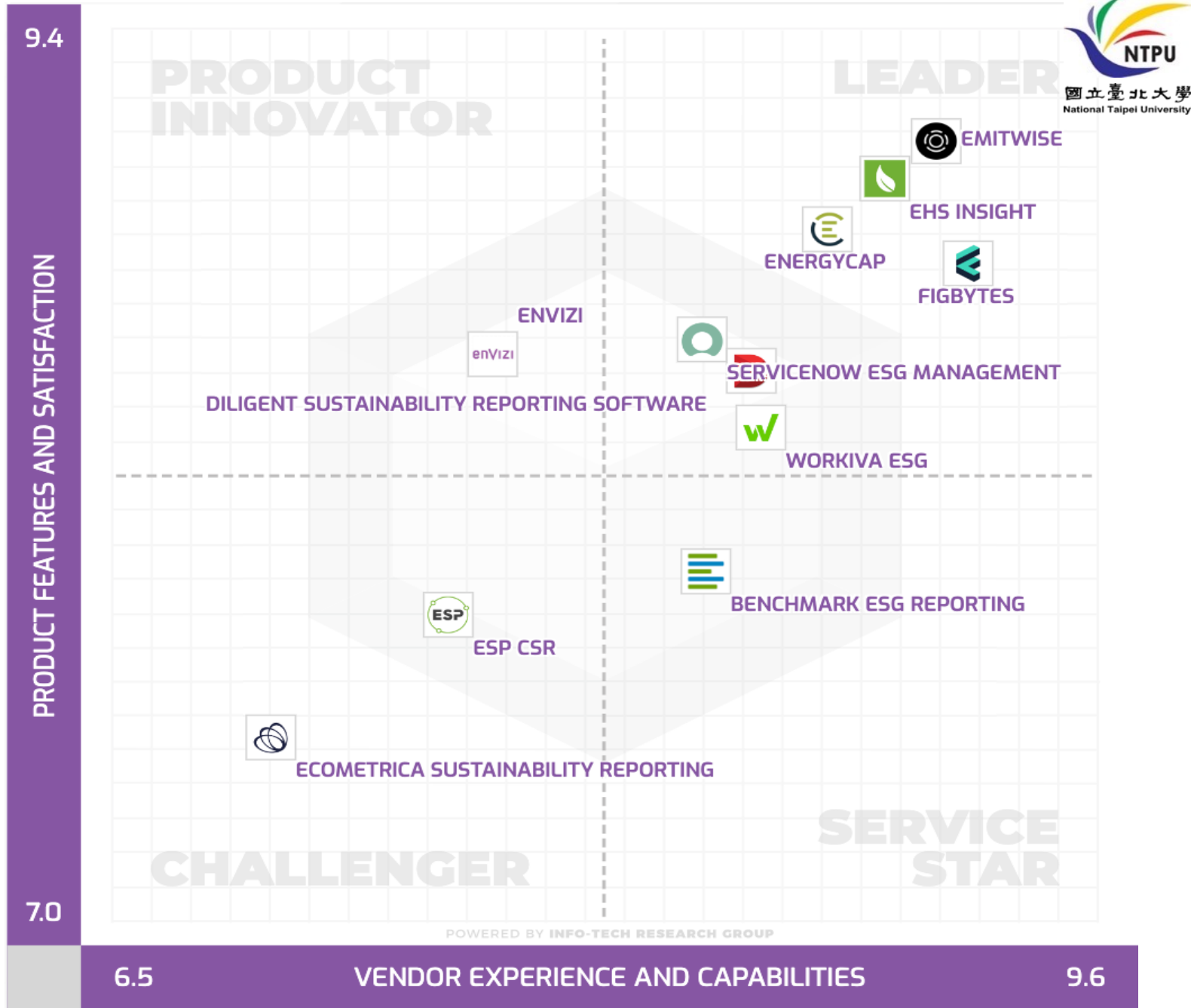

# Future Directions

- Integrating blockchain, IoT, and digital twins.
- Democratizing AI tools for all stakeholders.
- Promoting collaboration among experts and communities.

# Conclusion

- **Generative AI is transforming ESG analytics and sustainability innovation.**
- **Collaboration among researchers, policymakers, and innovators is key.**
- **Generative AI to build a sustainable future.**

# Summary

- **Generative AI**
- **ESG Rating**
- **ESG Reporting Generation**

# References

- Sherry Madera (2024), Navigating Sustainability Data: How Organizations can use ESG Data to Secure Their Future, Kogan Page
- Jun Xu, (2024) "AI in ESG for Financial Institutions: An Industrial Survey." arXiv preprint arXiv:2403.05541 (2024).
- Simon Thompson (2023), Green and Sustainable Finance: Principles and Practice in Banking, Investment and Insurance, 2nd Edition, Kogan Page.
- Chrissa Pagitsas (2023), Chief Sustainability Officers At Work: How CSOs Build Successful Sustainability and ESG Strategies, Apress.
- Wes McKinney (2022), "Python for Data Analysis: Data Wrangling with pandas, NumPy, and Jupyter", 3rd Edition, O'Reilly Media.
- Cino Robin Castelli, Cyril Shmatov (2022), Quantitative Methods for ESG Finance, Wiley
- Yi Zou, Mengying Shi, Zhongjie Chen, Zhu Deng, ZongXiong Lei, Zihan Zeng, Shiming Yang, HongXiang Tong, Lei Xiao, and Wenwen Zhou. (2023) "ESGReveal: An LLM-based approach for extracting structured data from ESG reports." arXiv preprint arXiv:2312.17264.
- Stuart Russell and Peter Norvig (2020), Artificial Intelligence: A Modern Approach, 4th Edition, Pearson.
- Numa Dhamani and Maggie Engler (2024), Introduction to Generative AI, Manning
- Denis Rothman (2024), Transformers for Natural Language Processing and Computer Vision - Third Edition: Explore Generative AI and Large Language Models with Hugging Face, ChatGPT, GPT-4V, and DALL-E 3, 3rd ed. Edition, Packt Publishing
- Jun Xu (2024). "GenAI and LLM for Financial Institutions: A Corporate Strategic Survey." Available at SSRN 4988118.
- Yuqi Nie, Yaxuan Kong, Xiaowen Dong, John M. Mulvey, H. Vincent Poor, Qingsong Wen, and Stefan Zohren (2024). "A Survey of Large Language Models for Financial Applications: Progress, Prospects and Challenges." arXiv preprint arXiv:2406.11903.
- Pravesh Agrawal, Szymon Antoniak, Emma Bou Hanna, Baptiste Bout, Devendra Chaplot, Jessica Chudnovsky, Diogo Costa et al. (2024) "Pixtral 12B." arXiv preprint arXiv:2410.07073.
- Yihan Cao, Siyu Li, Yixin Liu, Zhiling Yan, Yutong Dai, Philip S. Yu, and Lichao Sun (2023). "A Comprehensive Survey of AI-Generated Content (AIGC): A History of Generative AI from GAN to ChatGPT." arXiv preprint arXiv:2303.04226.
- Pengfei Liu, Weizhe Yuan, Jinlan Fu, Zhengbao Jiang, Hiroaki Hayashi, and Graham Neubig. (2023) "Pre-train, prompt, and predict: A systematic survey of prompting methods in natural language processing." ACM Computing Surveys 55, no. 9 (2023): 1-35.
- Wayne Xin Zhao, Kun Zhou, Junyi Li, Tianyi Tang, Xiaolei Wang, Yupeng Hou, Yingqian Min et al. (2023) "A Survey of Large Language Models." arXiv preprint arXiv:2303.18223.
- Touvron, Hugo, Louis Martin, Kevin Stone, Peter Albert, Amjad Almahairi, Yasmine Babaei, Nikolay Bashlykov et al. (2023) "Llama 2: Open Foundation and Fine-Tuned Chat Models." arXiv preprint arXiv:2307.09288 (2023).
- Rafailov, R., Sharma, A., Mitchell, E., Ermon, S., Manning, C. D., & Finn, C. (2023). Direct preference optimization: Your language model is secretly a reward model. arXiv preprint arXiv:2305.18290.
- Tunstall, Lewis, Edward Beeching, Nathan Lambert, Nazneen Rajani, Kashif Rasul, Younes Belkada, Shengyi Huang et al. "Zephyr: Direct Distillation of LM Alignment." arXiv preprint arXiv:2310.16944 (2023).
- Ouyang, L., Wu, J., Jiang, X., Almeida, D., Wainwright, C. L., Mishkin, P., ... & Lowe, R. (2022). Training language models to follow instructions with human feedback. arXiv preprint arXiv:2203.02155.
- Gozalo-Brizuela, Roberto, and Eduardo C. Garrido-Merchan (2023). "ChatGPT is not all you need. A State of the Art Review of large Generative AI models." arXiv preprint arXiv:2301.04655 (2023).
- Wenliang Dai, Junnan Li, Dongxu Li, Anthony Meng Huat Tiong, Junqi Zhao, Weisheng Wang, Boyang Li, Pascale Fung, and Steven Hoi. (2023) "InstructBLIP: Towards General-purpose Vision-Language Models with Instruction Tuning." arXiv preprint arXiv:2305.06500 (2023).
- Shahab Saquib Sohail, Faiza Farhat, Yassine Himeur, Mohammad Nadeem, Dag Øivind Madsen, Yashbir Singh, Shadi Atalla, and Wathiq Mansoor (2023). "The Future of GPT: A Taxonomy of Existing ChatGPT Research, Current Challenges, and Possible Future Directions." Current Challenges, and Possible Future Directions (April 8, 2023) (2023).
- Longbing Cao (2022). "Decentralized ai: Edge intelligence and smart blockchain, metaverse, web3, and desc." IEEE Intelligent Systems 37, no. 3: 6-19.
- Qinglin Yang, Yetong Zhao, Huawei Huang, Zehui Xiong, Jiawen Kang, and Zibin Zheng (2022). "Fusing blockchain and AI with metaverse: A survey." IEEE Open Journal of the Computer Society 3 : 122-136.
- Ouyang, L., Wu, J., Jiang, X., Almeida, D., Wainwright, C. L., Mishkin, P., ... & Lowe, R. (2022). Training language models to follow instructions with human feedback. arXiv preprint arXiv:2203.02155.
- Min-Yuh Day (2024), Python 101, <https://tinyurl.com/aintpupython101>