

# Sustainability and ESG Data Analytics

## Environmental, Social, and Governance (ESG) in Net-Zero Digital Transformation

1141ESGDA02

MBA, IM, NTPU (M5265) (Fall 2025)

Wed 2, 3, 4 (9:10-12:00) (B3F17)



<https://meet.google.com/miy-fbif-max>

 **NVIDIA**  
University Ambassador  
Certified Instructor

 **aws educate** | Cloud Ambassador  
2020 Cohort

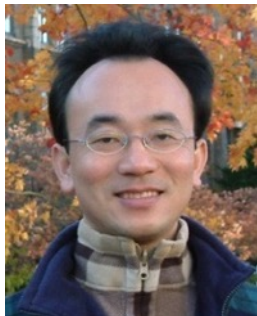

**Min-Yuh Day, Ph.D,**  
**Professor and Director**

**Institute of Information Management, National Taipei University**

<https://web.ntpu.edu.tw/~myday>



# Syllabus

Week	Date	Subject/Topics
1	2025/09/10	Introduction Sustainability and ESG Data Analytics
2	2025/09/17	Environmental, Social, and Governance (ESG) in Net-Zero Digital Transformation
3	2025/09/24	Data Science for Sustainability and ESG
4	2025/10/01	Case Study on Sustainability and ESG Data Analytics I
5	2025/10/08	Web 3.0 and Big Data Analysis in Fintech, Green and Sustainable Finance
6	2025/10/15	ESG Data Gathering, Analysis, and Visualization

# Syllabus

<b>Week</b>	<b>Date</b>	<b>Subject/Topics</b>
<b>7</b>	<b>2025/10/22</b>	<b>NVIDIA Building RAG Agents with LLMs Part I: LLM Services and AI Foundation Models</b>
<b>8</b>	<b>2025/10/29</b>	<b>Self-Learning</b>
<b>9</b>	<b>2025/11/05</b>	<b>Midterm Project Report</b>
<b>10</b>	<b>2025/11/12</b>	<b>NVIDIA Building RAG Agents with LLMs Part II: Document Loading, Chunking, and Embeddings</b>
<b>11</b>	<b>2025/11/19</b>	<b>NVIDIA Building RAG Agents with LLMs Part III: Retrieval-Augmented Generation with Vector Stores and RAG Evaluation</b>

# Syllabus

**Week Date Subject/Topics**

**12 2025/11/26 Case Study on Sustainability and ESG Data Analytics II**

**13 2025/12/03 Artificial Intelligence of things (AIoT) in ESG and Sustainability Applications**

**14 2025/12/10 Generative AI for ESG Rating and Reporting Generation**

**15 2025/12/17 Final Project Report I**

**16 2025/12/24 Final Project Report II**

**Environmental, Social, and  
Governance (ESG)  
in Net-Zero Digital Transformation**

# Outline

- **Environmental, Social, and Governance (ESG)**
- **Net-Zero Digital Transformation**
  - **Net-Zero Transformation**
  - **Digital Transformation**

# Sustainability and ESG Data Analytics



**ESG:**

**Environmental**

**Social**

**Governance**

**CSR:  
Corporate  
Social  
Responsibility**

# ESG in Net-Zero Digital Transformation: Foundations and Frameworks

- **Environmental, Social, and Governance (ESG)**
- **Net-Zero Transformation**
- **Digital Transformation**
- **Opportunities and responsibilities**



# Tech for Good – Your Solutions!

- **Challenge:**  
**Most innovative tech solution  
to an environmental OR  
social problem**



Cino Robin Castelli, Cyril Shmatov (2022),  
**Quantitative Methods for ESG Finance,**  
Wiley

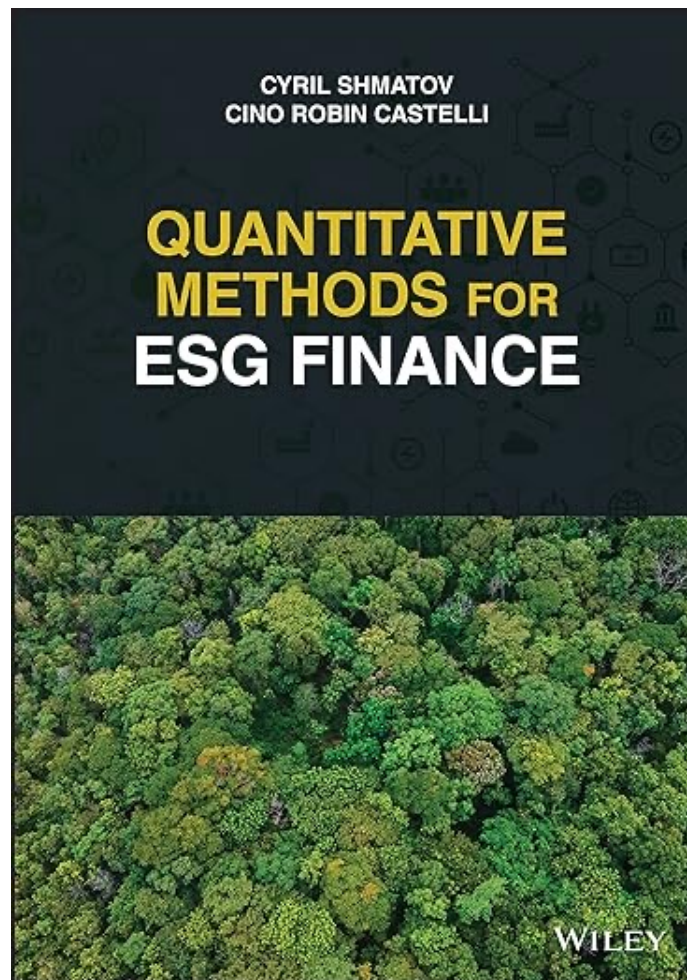

Simon Thompson (2023),  
**Green and Sustainable Finance:**  
**Principles and Practice in Banking, Investment and Insurance,**  
2nd Edition, Kogan Page.

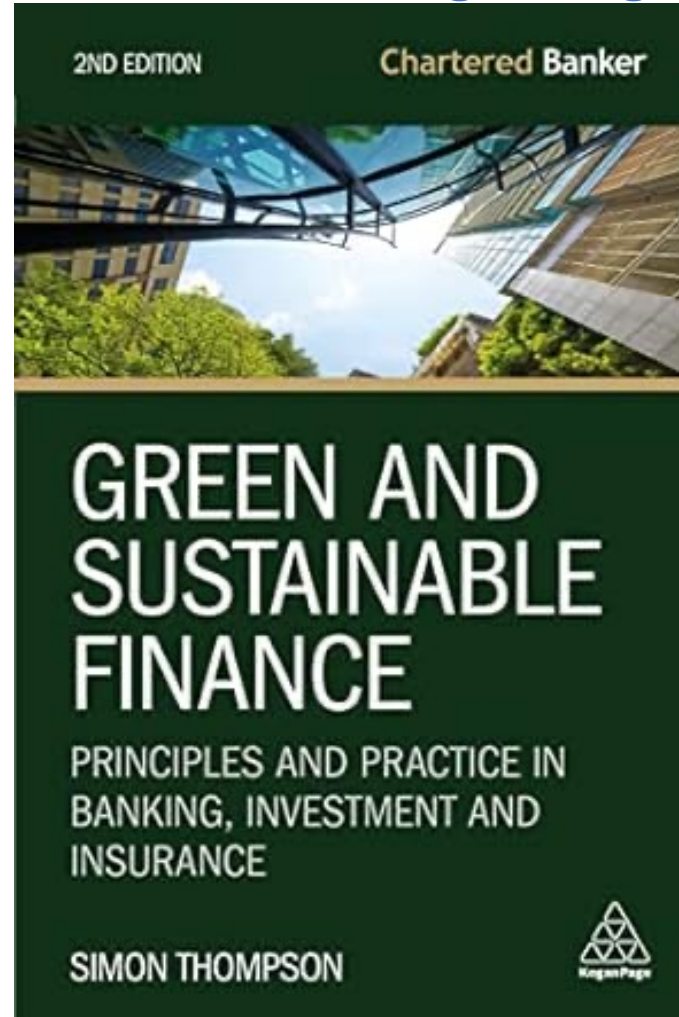

Chrissa Pagitsas (2023),  
**Chief Sustainability Officers At Work:  
How CSOs Build Successful Sustainability and ESG Strategies,**  
Apress.

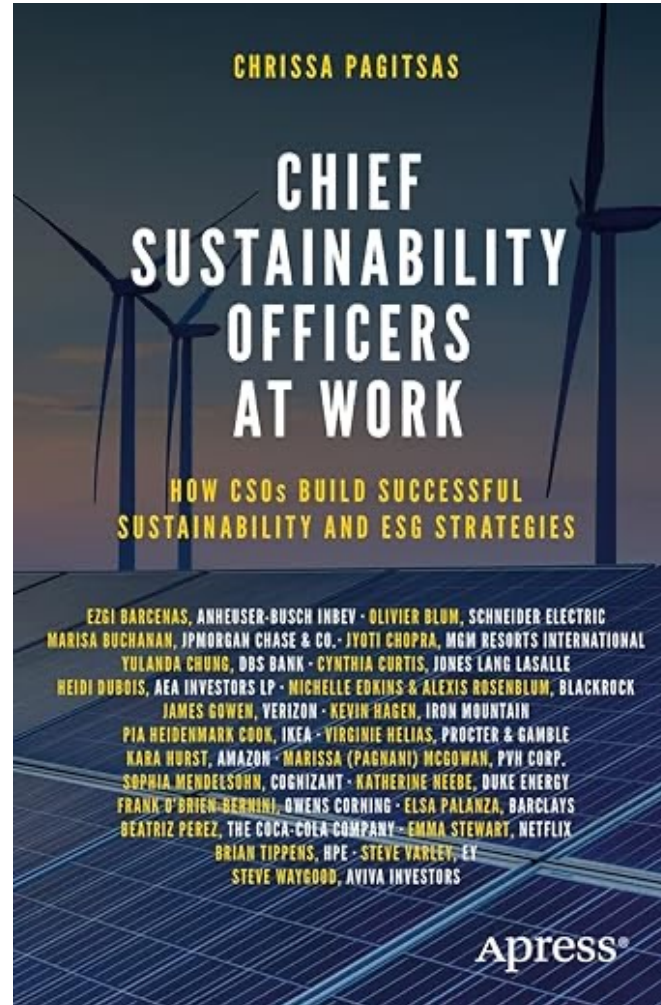

**Sherry Madera (2024),**  
**Navigating Sustainability Data: How Organizations can use ESG**  
**Data to Secure Their Future, Kogan Page**

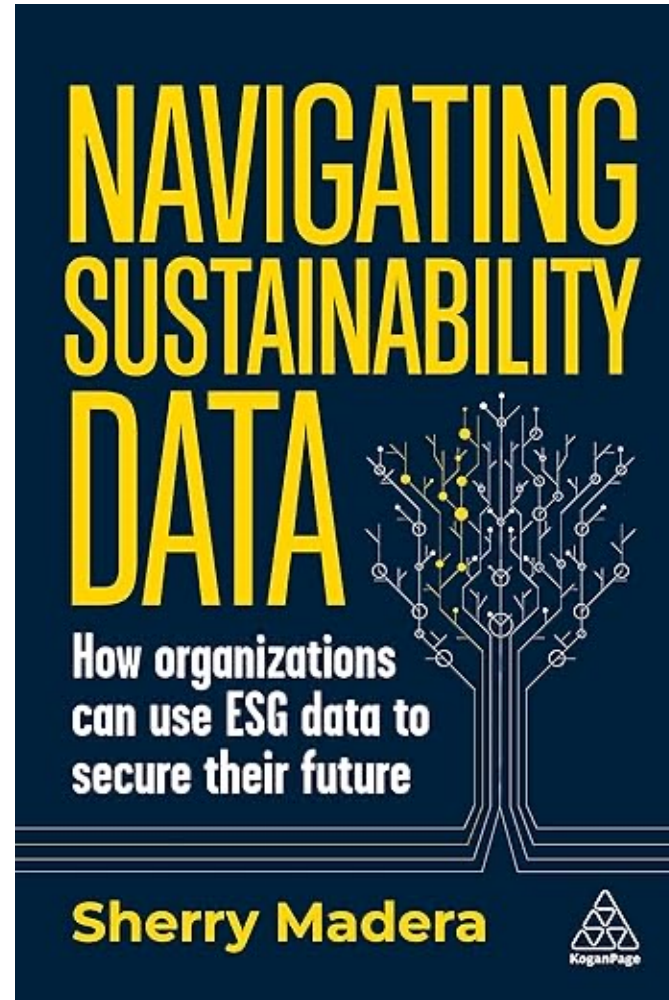

# ESG and Net-Zero: The Essentials

- **Environmental**
  - **Climate impact, resource use, pollution, biodiversity**
- **Social**
  - **Labor practices, human rights, community impact, diversity & inclusion**
- **Governance**
  - **Transparency, ethics, board structure, risk management**
- **Net-Zero**
  - **Balancing emissions produced with emissions removed globally**

# Net-Zero Transformation

- **Ambition**

- Aligned to achieving global net zero by no later than 2050 & to limit warming to 1.5° C

- **Governance**

- Accountability driven from the top

- **Strategy**

- Embedded and aligned net zero into company strategy

- **Enterprise**

- Key operating model changes in support of transformation

- **Supply chains**

- Transformed net zero supply chains

- **Innovation**

- Developed innovation and technologies to deliver net zero

- **Finance**

- Financing the net zero transformation

- **Transparency**

- Communicating action

- **Engagement**

- Enhancing the pace and scale of net zero action

# Net-Zero Transformation Enablers

## Net-zero industry performance

The four drivers of industry net greenhouse gas (GHG) emissions:

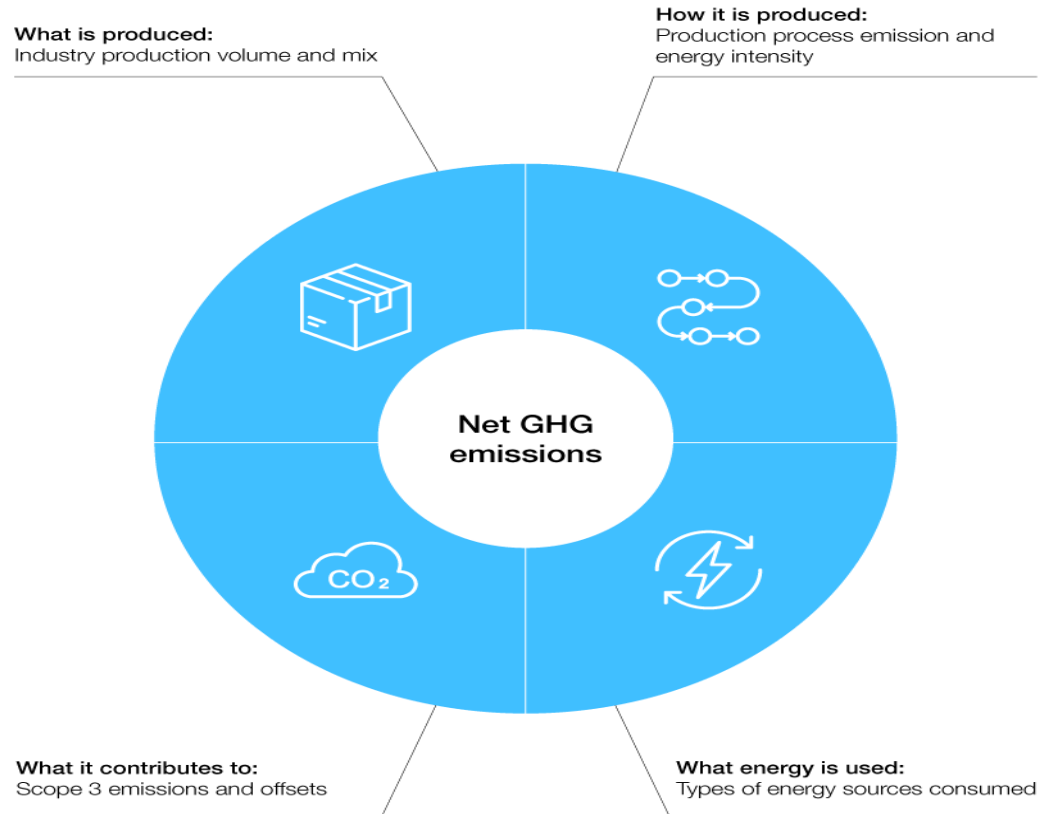

## Net-zero industry readiness

The five enabling dimensions of industry net-zero transformation:

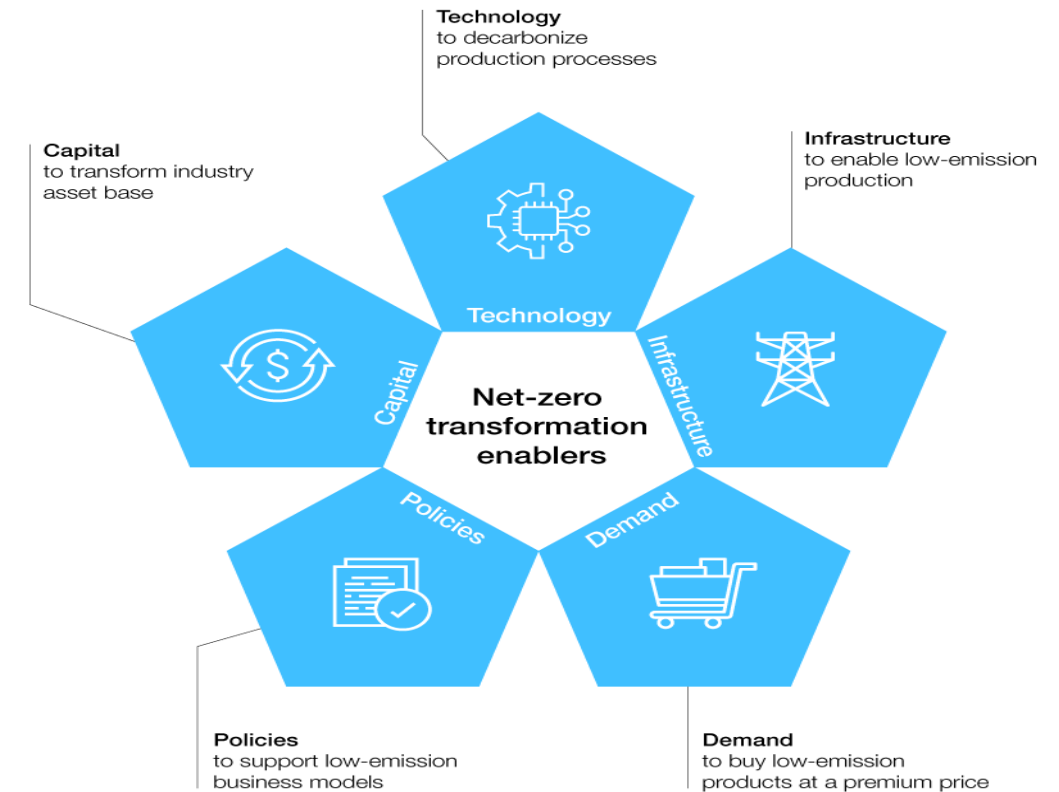

# The Net Zero Transition

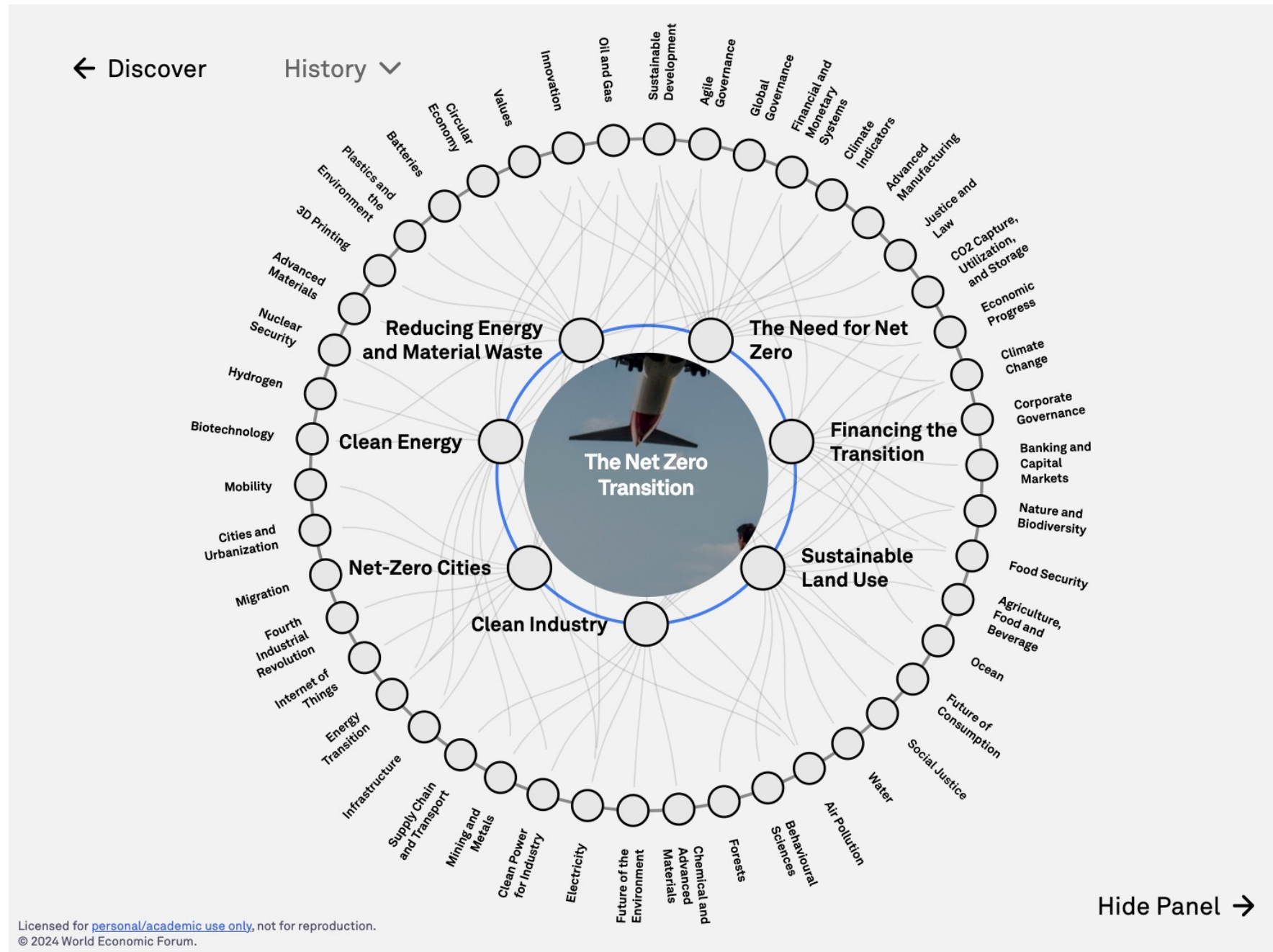

# The Digital Transformation of Business

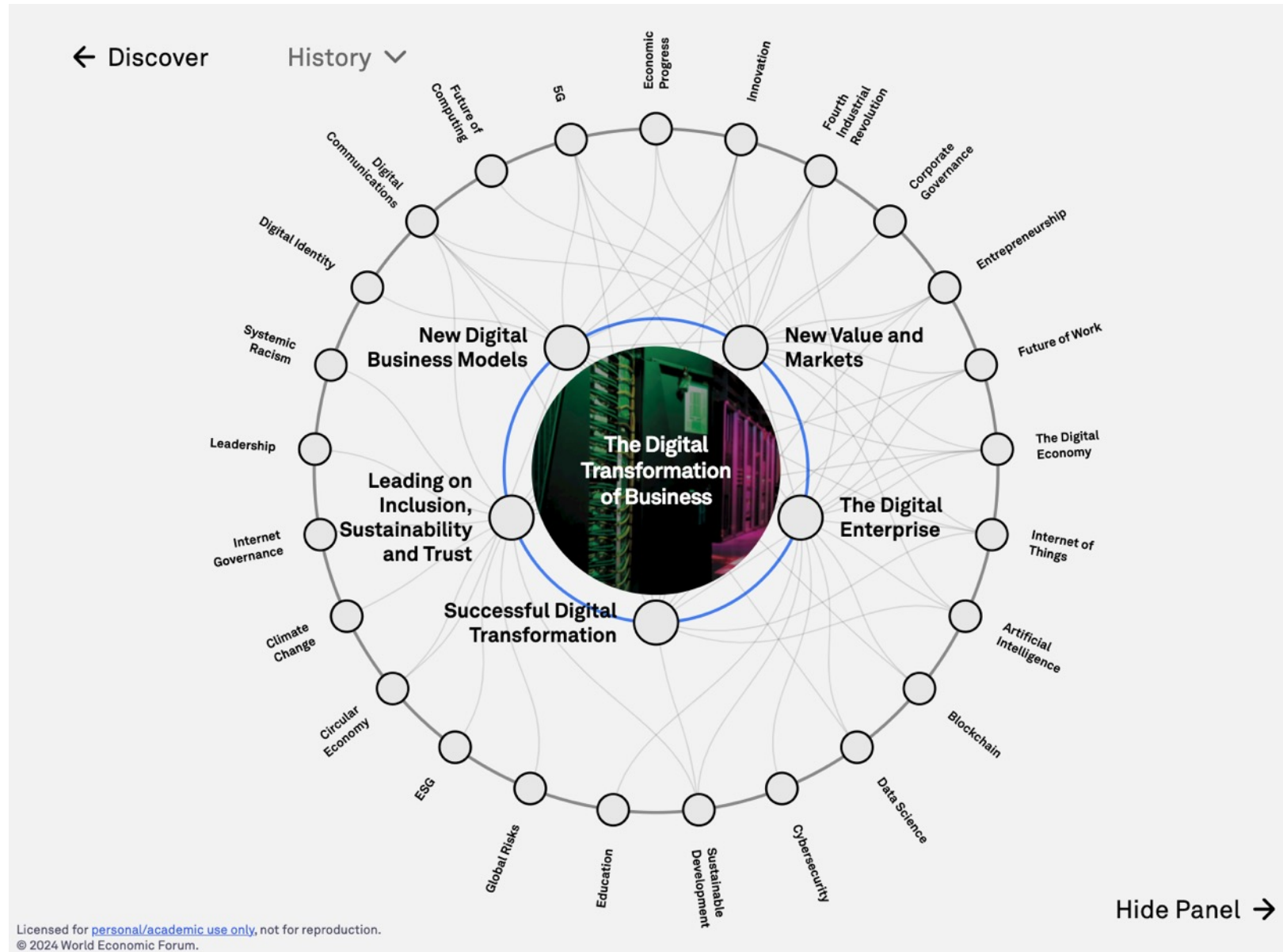

# Digital Transformation

Dimensions	Categories
A. BUSINESS MODELS	Business Process Innovation Business Strategy
B. DIGITAL BUSINESS	Digital Culture, Literacy and Skills Digital Economy Innovation and Socio-technical Shared Values
C. TECHNOLOGIES	Technology and Innovation Management Artificial Intelligence Big Data Internet of Things Industry 4.0
D. SUSTAINABILITY	Sustainable Business Sustainable Competitive Advantage Sustainable Development Sustainable Innovation
E. HUMAN RESOURCES	Employee Experience Career Dynamics
F. SMART CITIES	Sustainable Smart Manufacturing Digital Manufacturing

# Digital Transformation Framework

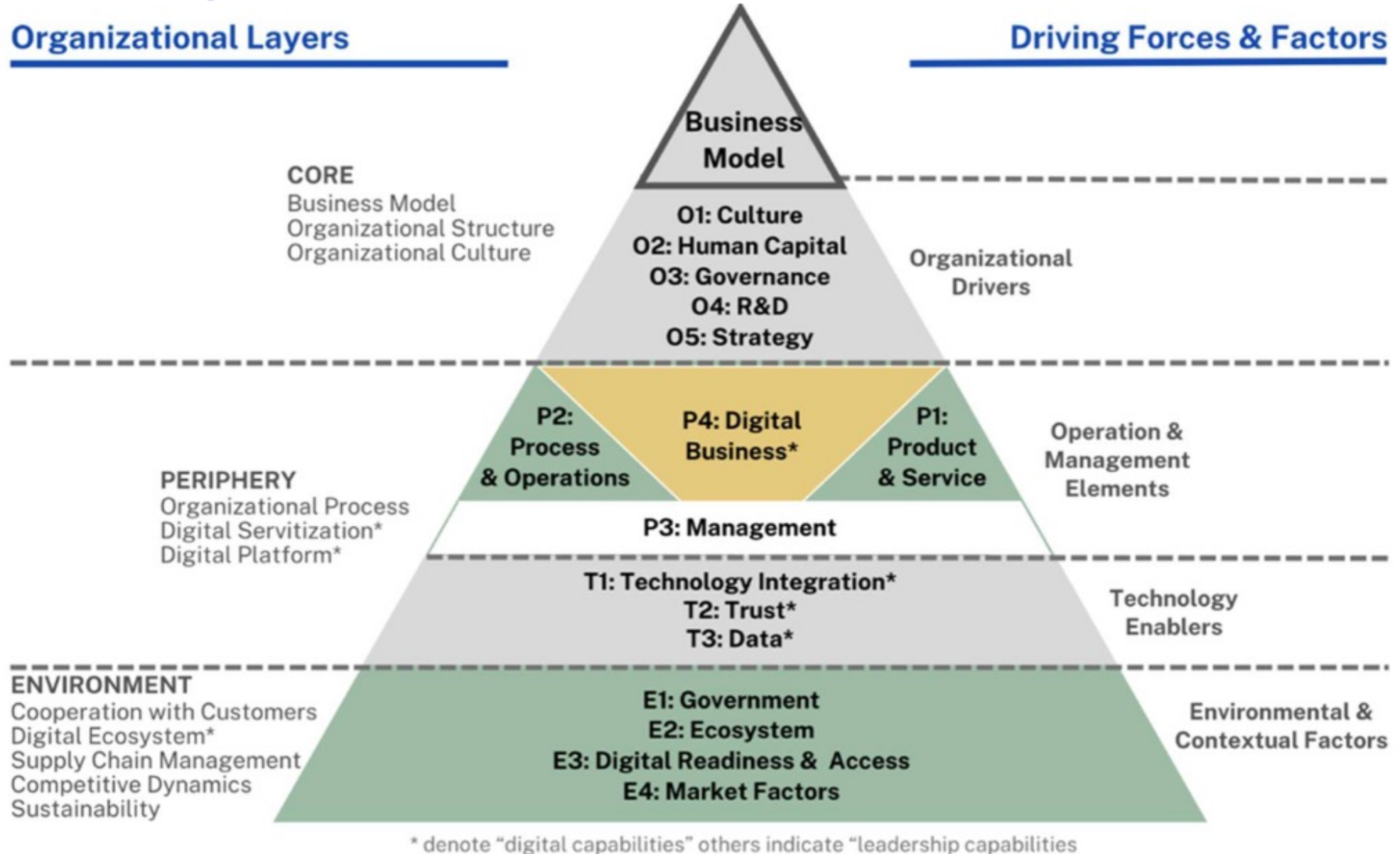

# Digital Transformation: Theoretical and practical dimensions

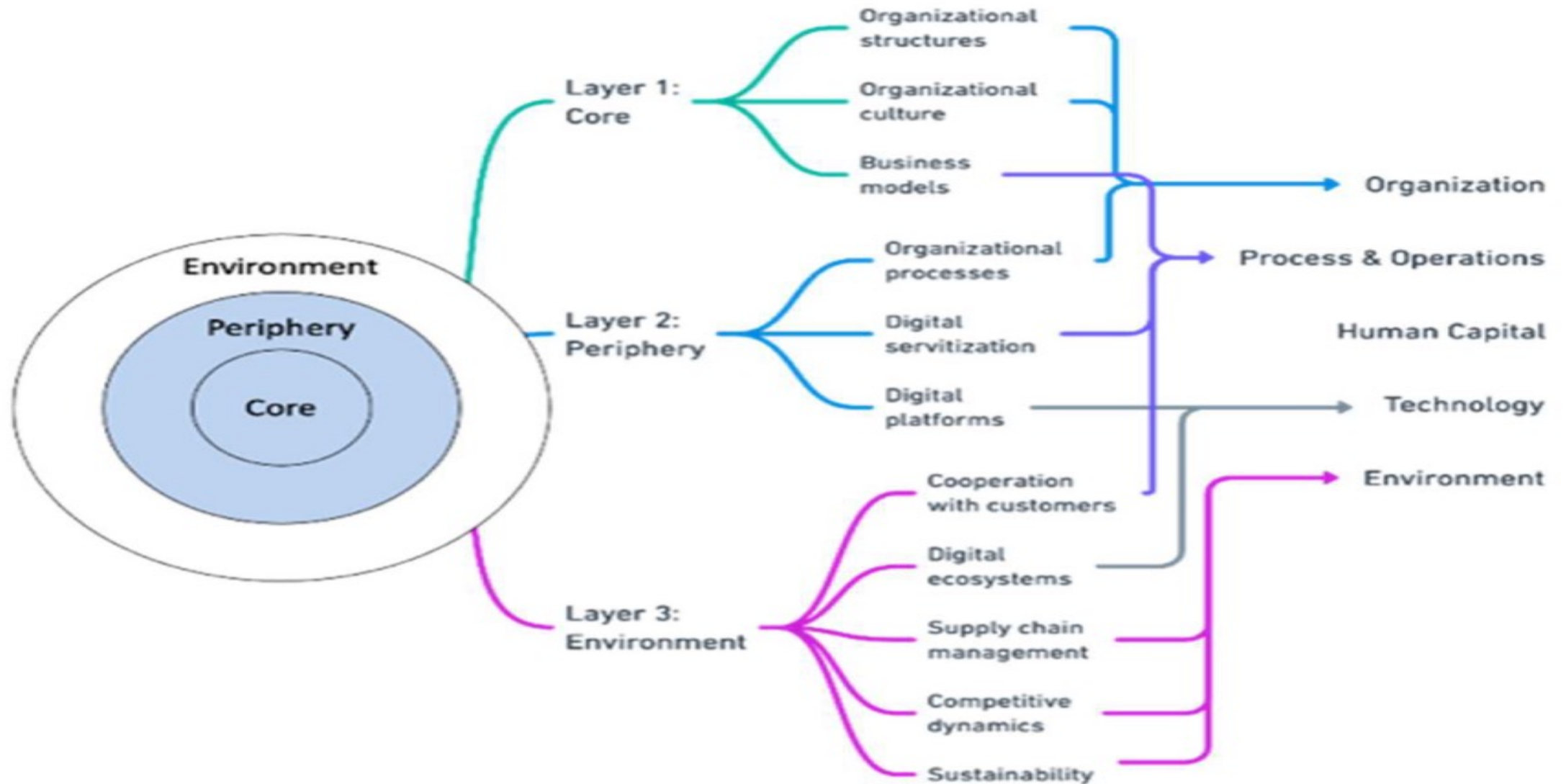

Made with  Whimsical

# AI Technology for Net-Zero Energy Transition

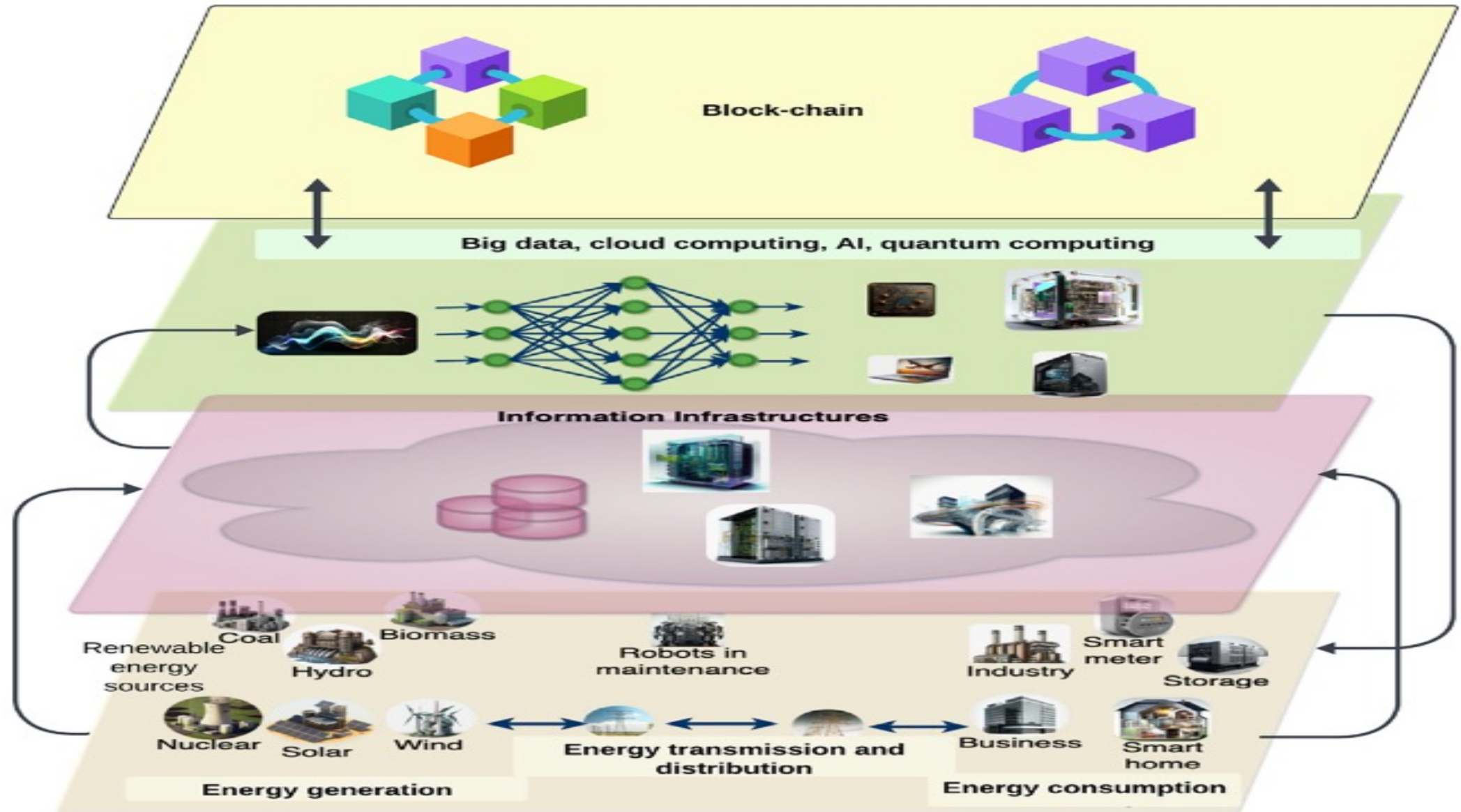

# AI Innovations for Net-Zero Transformation

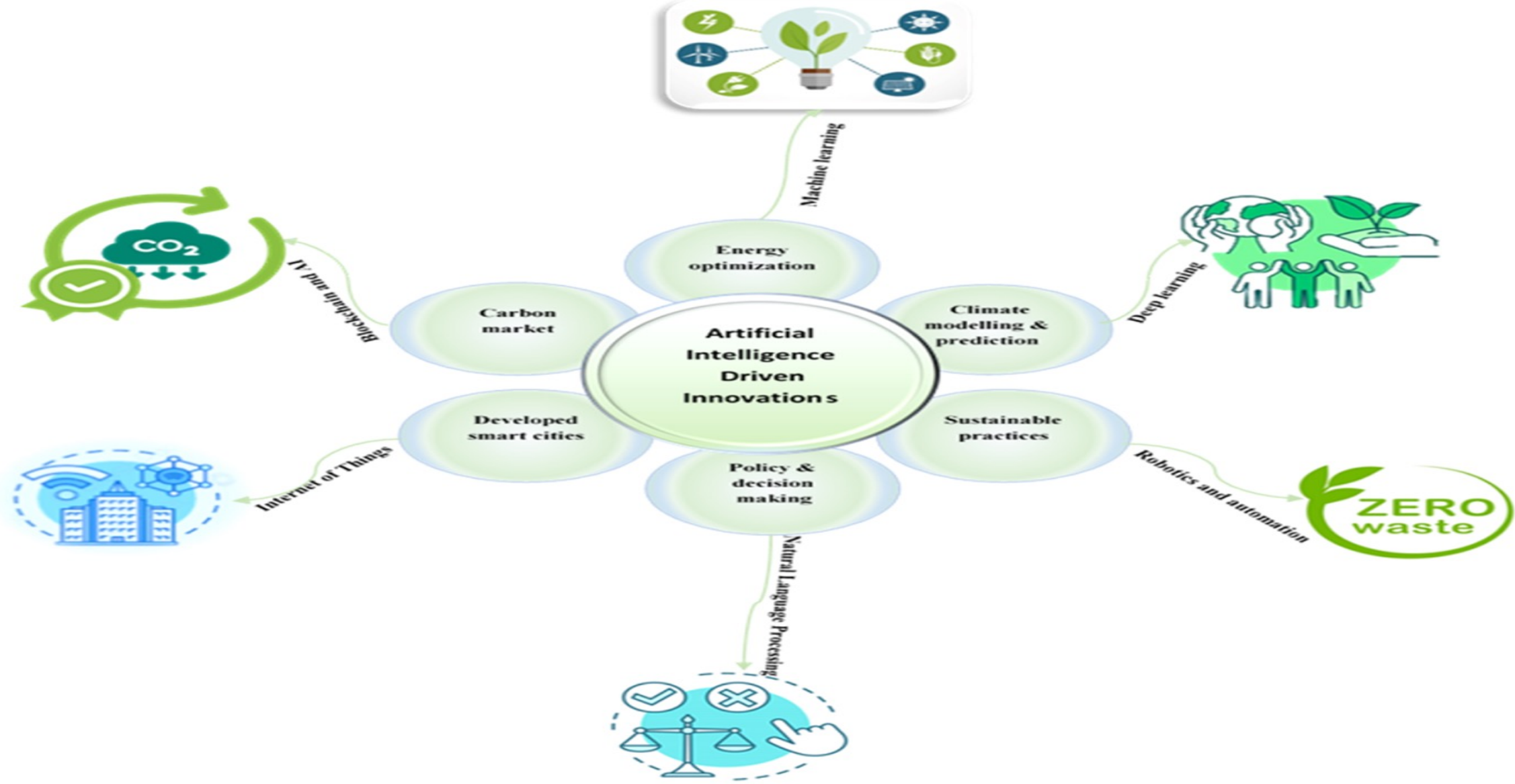

Source: Olawade, D. B., Wada, O. Z., David-Olawade, A. C., Fapohunda, O., Ige, A. O., & Ling, J. (2024). Artificial intelligence potential for net zero sustainability: Current evidence and prospects. Next Sustainability, 4, 100041.

# AI for Energy Systems and Agentic Digital Twins

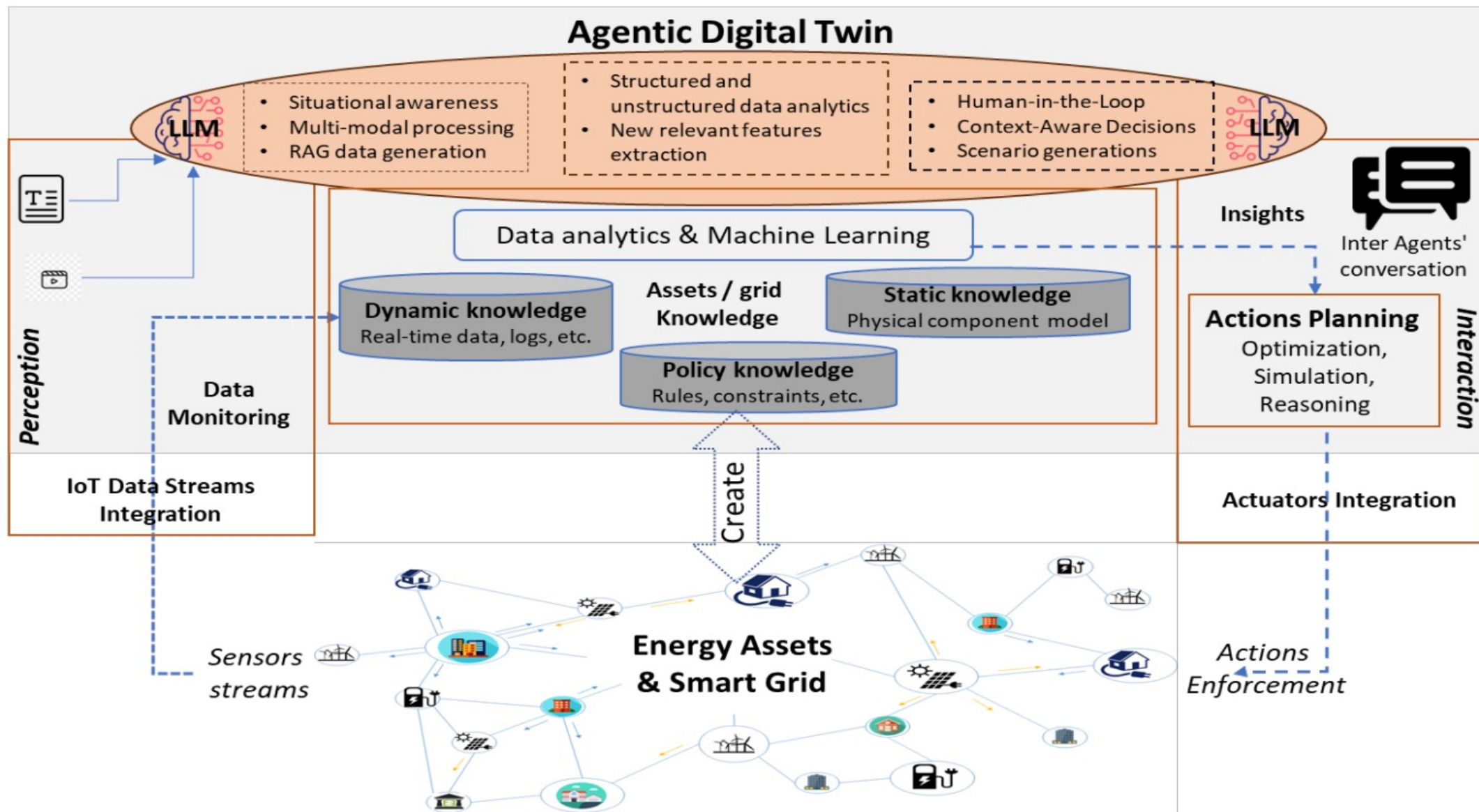

# Local Power System Digitalization Transition to Net-Zero

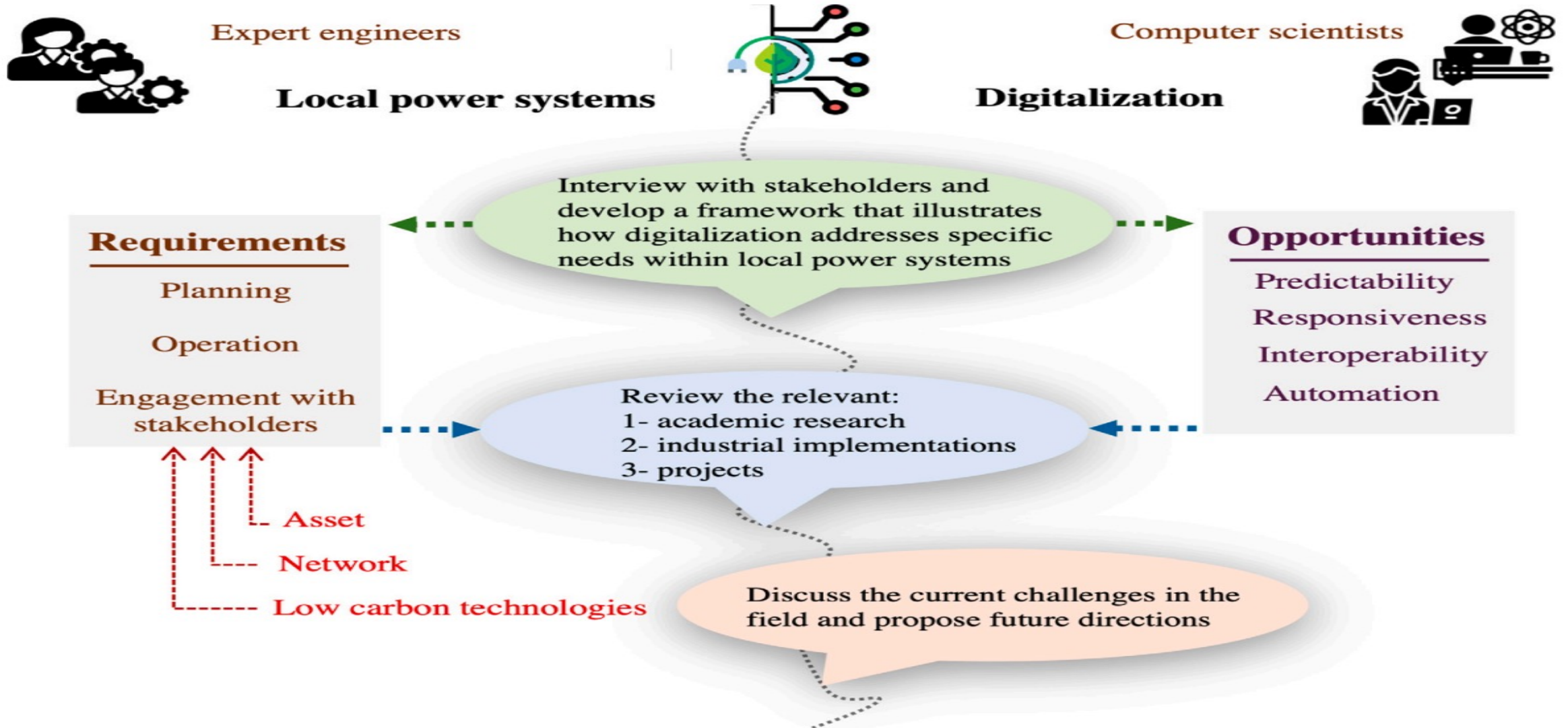

# Digital Transformation for Smart Net-Zero Cities

(Technology, People, Data, and Process)

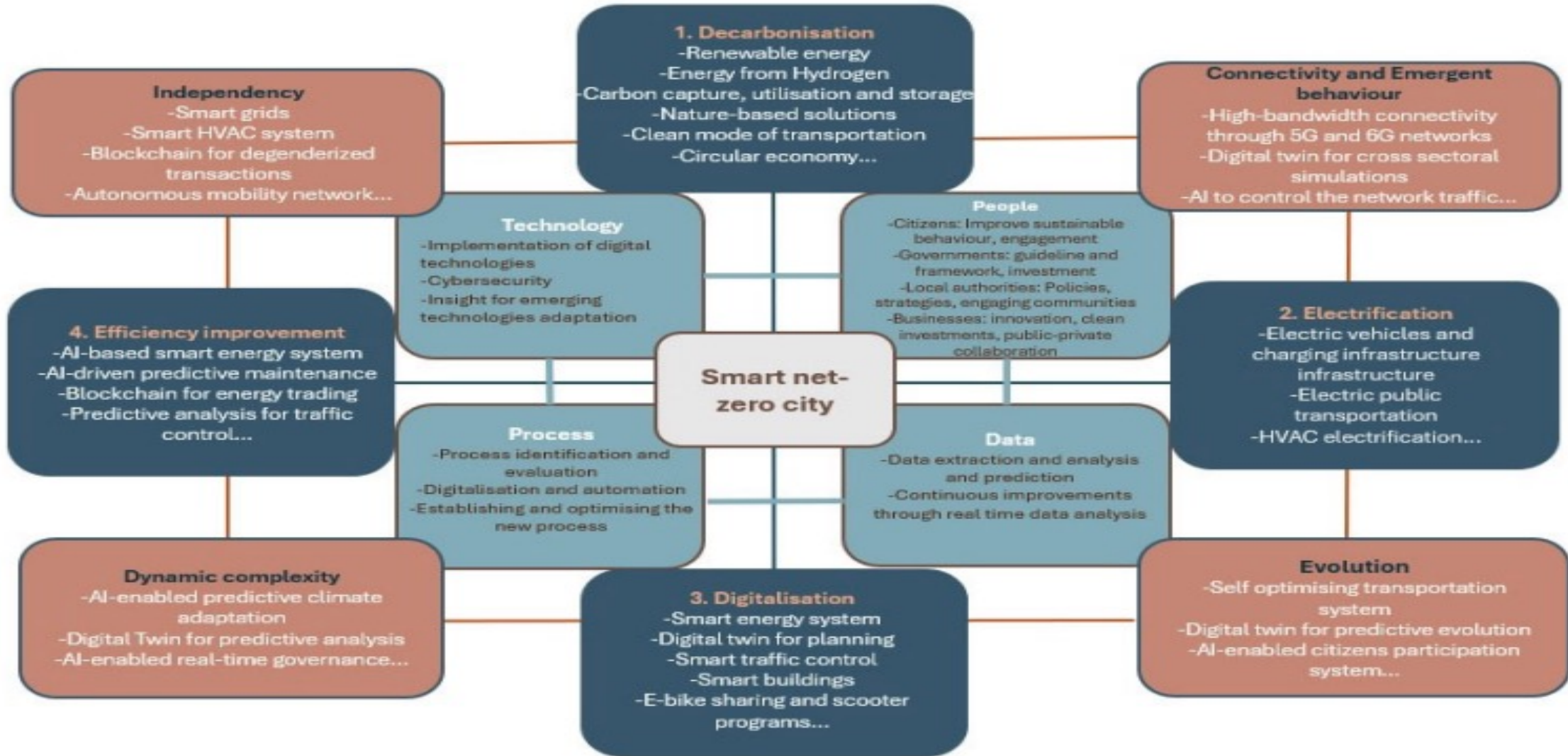

# Sustainable Development Goals (SDGs)

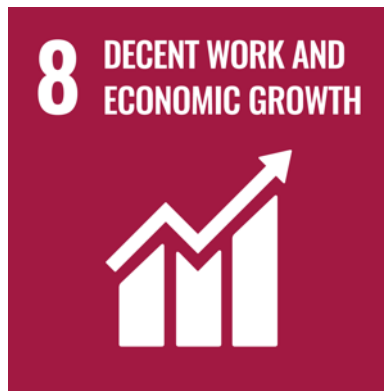

# Evolution of Sustainable Finance Research

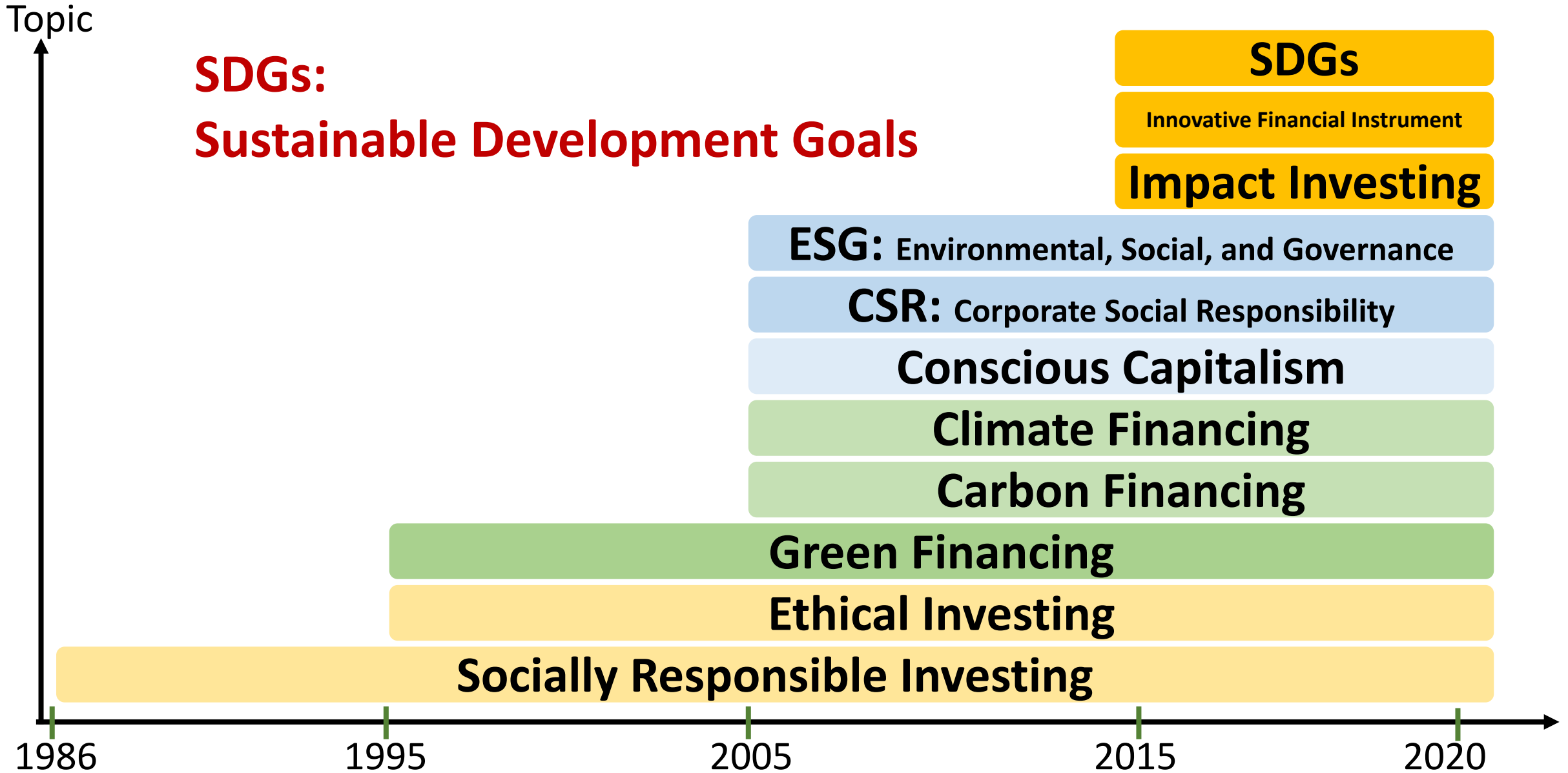

Source: Kumar, S., Sharma, D., Rao, S., Lim, W. M., & Mangla, S. K. (2022). Past, present, and future of sustainable finance: Insights from big data analytics through machine learning of scholarly research. *Annals of Operations Research*, 1-44.

# Sustainable Development Goals (SDGs) and 5P

Partnership

Peace

Prosperity

People

Planet



# ESG to 17 SDGs

## ENVIRONMENT



## SOCIAL



## GOVERNANCE



# ESG to 17 SDGs

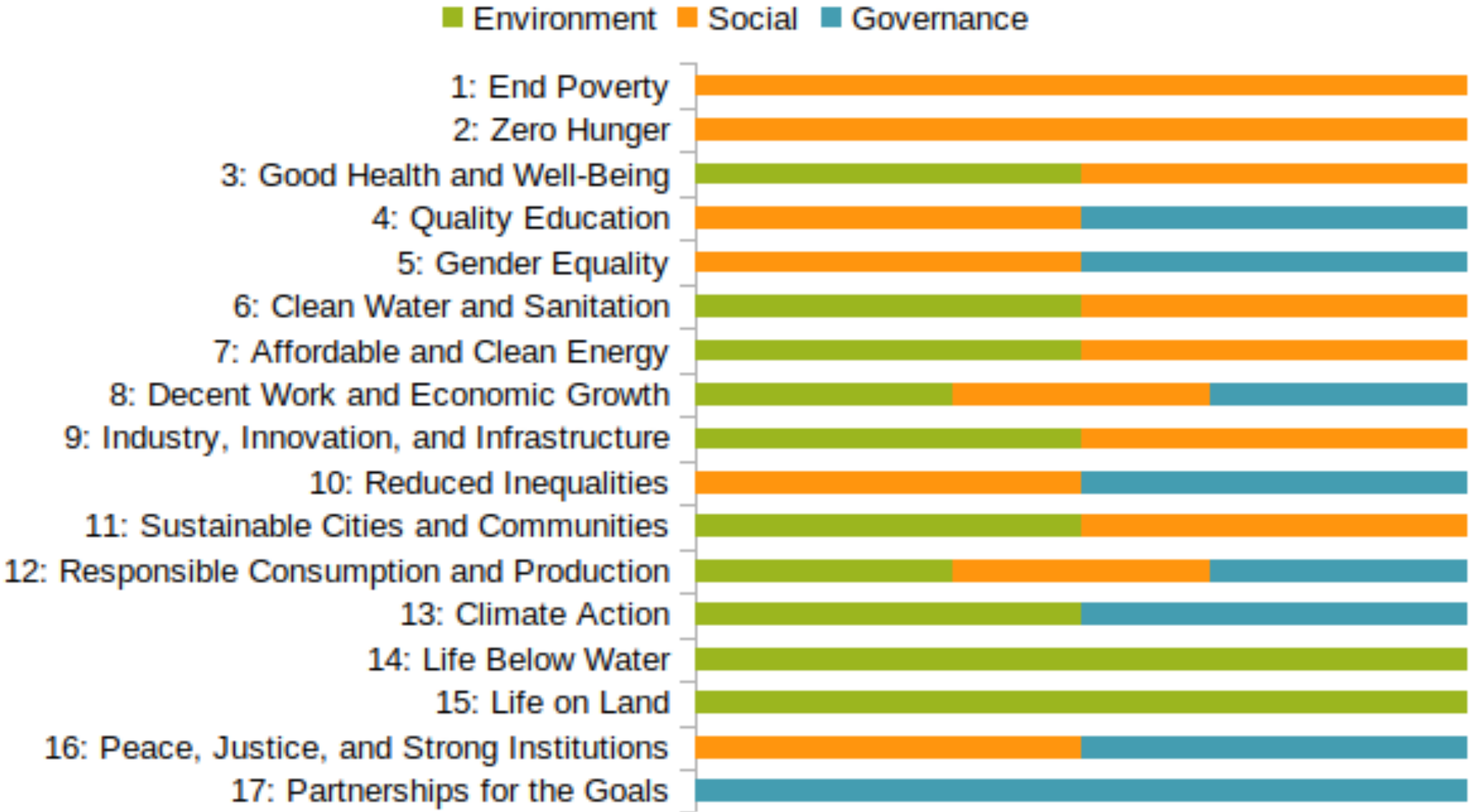

Source: <https://sustainometric.com/esg-to-sdgs-connected-paths-to-a-sustainable-future/>

# Where ESG Meets – It's All Connected

- **Environmental Justice**
  - **Underserved communities disproportionately impacted by pollution, climate hazards**
- **Responsible Tech Supply Chains**
  - **Resource extraction, e-waste, labor rights across the tech lifecycle**
- **Inclusive Product Design**
  - **Accessibility, addressing digital divides, social impacts of technology.**

# Digital Transformation: Enabler and Challenge

- **Enabler**

- **Data-driven decision-making, efficiency gains, new business models, collaboration**
- **AI optimizing renewable energy**

- **Challenge**

- **Energy consumption, e-waste, planned obsolescence, AI ethics**
- **AI servers representing increased energy use**

# Mapping the ESG Standards Landscape

- **The most prevalent ESG reporting frameworks**
  - **GRI (Global Report Initiative)**
  - **CDP (Carbon Disclosure Project)**
  - **SASB (Sustainability Accounting Standards Board)**
  - **ISSB (International Sustainability Standards Board)**
  - **TCFD (Task Force on Climate-related Financial Disclosures)**
- **How companies choose**
  - **Materiality, industry-specific standards, investor alignment**

# GRI (Global Report Initiative)



Standards ▾

How to use the GRI Standards ▾

Reporting support ▾

Public policy & partnerships ▾

About GRI ▾

News ▾

Goals and targets database

Sign In

Search 🔍

Donate Now



## The global leader for impact reporting

Welcome to GRI. For over 25 years, we have developed and delivered the global best practice for how organizations communicate and demonstrate accountability for their impacts on the environment, economy and people.

We provide the world's most widely used sustainability reporting standards, which cover topics that range from biodiversity to tax, waste to emissions, diversity and equality to health and safety. As such, GRI reporting is the enabler for transparency and dialogue between companies and their stakeholders.

[Access the GRI Standards →](#)

Feedback

# CDP (Carbon Disclosure Project)



[Guidance & questionnaires](#) [Contact](#) [Regional websites](#) ▾ [Language](#) ▾

[About us](#) [Our work](#) [Why disclose?](#) [Become a member](#) [Data and insights](#)

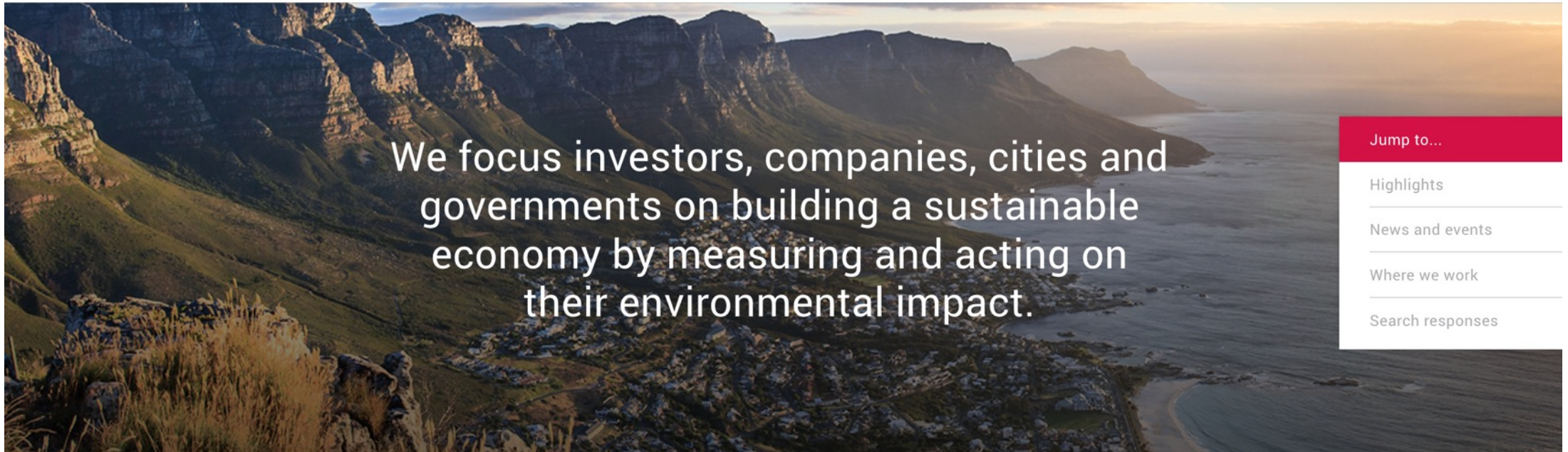

We focus investors, companies, cities and governments on building a sustainable economy by measuring and acting on their environmental impact.

Jump to...

- Highlights
- News and events
- Where we work
- Search responses

CDP is a not-for-profit charity that runs the global disclosure system for [investors](#), [companies](#), [cities](#), [states and regions](#) to manage their environmental impacts. Over the past 20 years we have created a system that has resulted in unparalleled engagement on environmental issues worldwide. Find out more about [how we work](#).

<https://www.cdp.net/>

# SASB (Sustainability Accounting Standards Board)

IFRS Foundation

Other Resources: [The ISSB](#) [Integrated Reporting Framework](#)



[✉ Subscribe](#) [↓ Download Standards](#)

[About](#) [SASB Standards](#) [Using the SASB Standards](#) [Pathway to ISSB](#) [Education](#) [Membership](#)

An aerial photograph showing a winding river through a lush green landscape with a dense forest on the right side.

**SASB Standards: Your pathway to ISSB**

[Learn more](#)

<https://sasb.org/>

# ISSB (International Sustainability Standards Board)



ABOUT US | IFRS ACCOUNTING | IFRS SUSTAINABILITY

Home > International Sustainability Standards Board

## International Sustainability Standards Board

ABOUT

MEMBERS

MEETINGS

RESOURCES

NEWS

### About the International Sustainability Standards Board

The Trustees of the IFRS Foundation announced the formation of the International Sustainability Standards Board (ISSB) on 3 November 2021 at COP26 in Glasgow, following strong market demand for its establishment. The ISSB is developing—in the public interest—standards that will result in a high-quality, comprehensive global baseline of sustainability disclosures focused on the needs of investors and the financial markets.

Sustainability factors are becoming a mainstream part of investment decision-making. There are increasing calls for companies to provide high-quality, globally comparable information on sustainability-related risks and opportunities, as indicated by feedback from many consultations with market

#### Related information

[Sustainability FAQs](#)

[General Sustainability-related Disclosures project](#)

[Climate-related Disclosures project](#)

[Consolidated organisations](#)

<https://www.ifrs.org/groups/international-sustainability-standards-board/>

# TCFD

## (Task Force on Climate-related Financial Disclosures)



<https://www.ifrs.org/sustainability/tcf/>



ABOUT US | IFRS ACCOUNTING | IFRS SUSTAINABILITY

Home > ISSB and TCFD

### ISSB and TCFD

The Financial Stability Board has announced that the work of the TCFD has been completed, with the ISSB's Standards marking the '**culmination of the work of the TCFD**'.

Companies applying IFRS S1 *General Requirements for Disclosure of Sustainability-related Financial Information* and IFRS S2 *Climate-related Disclosures* will meet the TCFD recommendations as the recommendations are fully incorporated into the ISSB's Standards.

Companies can continue to use the **TCFD recommendations** should they choose to do so, and some companies may still be required to use the TCFD recommendations. Using the recommendations is a good entry point for companies as they move to use the ISSB's Standards.

The IFRS Foundation has **published a comparison** of the requirements in IFRS S2 and the TCFD recommendations.

#### Related Information

[IFRS Foundation welcomes culmination of TCFD work and transfer of TCFD monitoring responsibilities to ISSB from 2024](#)

[Comparison: IFRS S2 Climate-related Disclosures with the TCFD Recommendations](#)

[Resource: Making the transition from TCFD to ISSB](#)

[IFRS Sustainability Standards Navigator](#)

<https://www.fsb-tcf.org/>

# CSRD

## (Corporate Sustainability Reporting Directive)

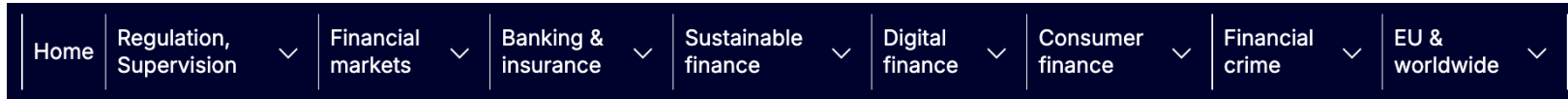

[Home](#) > [Financial markets](#) > [Company reporting and auditing](#) > [Company reporting](#) > Corporate sustainability reporting

### Corporate sustainability reporting

EU rules require large companies and listed companies to publish regular reports on the social and environmental risks they face, and on how their activities impact people and the environment.

#### PAGE CONTENTS

- What the EU is doing and why
- Corporate sustainability reporting explained
- Policy making timeline
- Relevant legislation
- Related links

#### What the EU is doing and why

EU law requires companies above a certain size to disclose information on what they see as the risks and opportunities arising from social and environmental issues, and on the impact of their activities on people and the environment.

This helps investors, civil society organisations, consumers and other stakeholders to evaluate the sustainability performance of companies, as part of the [European green deal](#) .

The first companies subject to the [Corporate Sustainability Reporting Directive \(CSRD\)](#) , have to apply the new rules for the first time in the 2024 financial year, for reports published in 2025.

Companies subject to the CSRD have to report according to European Sustainability Reporting Standards (ESRS). The standards are developed in a draft form by the [EFRAG, previously known as the European Financial Reporting Advisory Group](#) , an independent body bringing together various different stakeholders.

# The Human Impact of ESG Choices

- **Digital Initiatives**
- **This isn't abstract, it's about improving lives**
- **Positive potential when ESG is prioritized**



# Agentic AI for ESG Applications

# AI, ML, DL, Generative AI

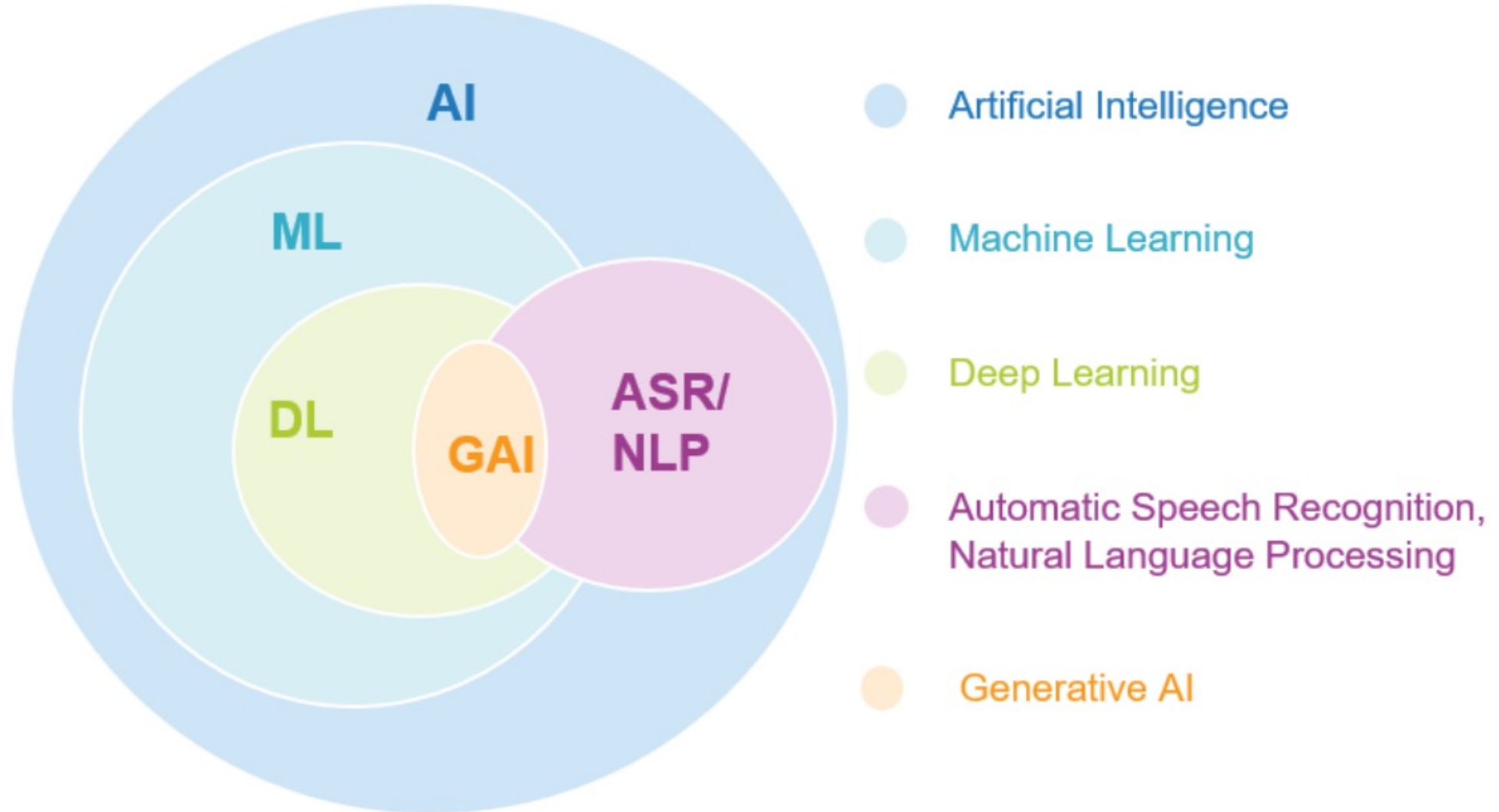

# Generative AI, Agentic AI, Physical AI

## Physical AI

Self-driving cars  
General robotics

## Agentic AI

Coding assistants  
Customer service  
Patient care

## Generative AI

Digital marketing  
Content creation

## Perception AI

Speech recognition  
Deep recommender systems  
Medical imaging

## 2012 AlexNet

Deep learning breakthrough

# Generative AI

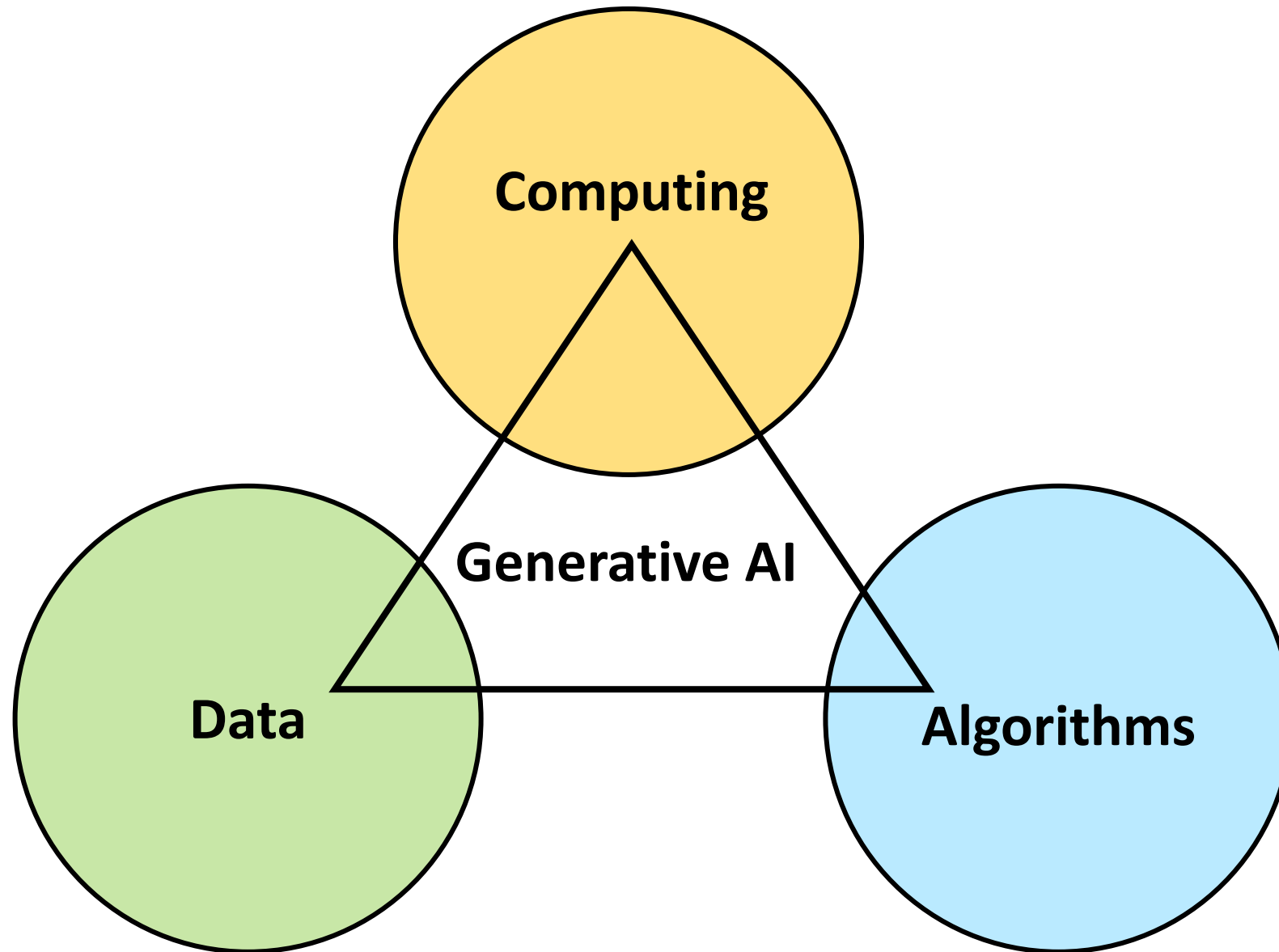

# From Generative AI to Agentic AI

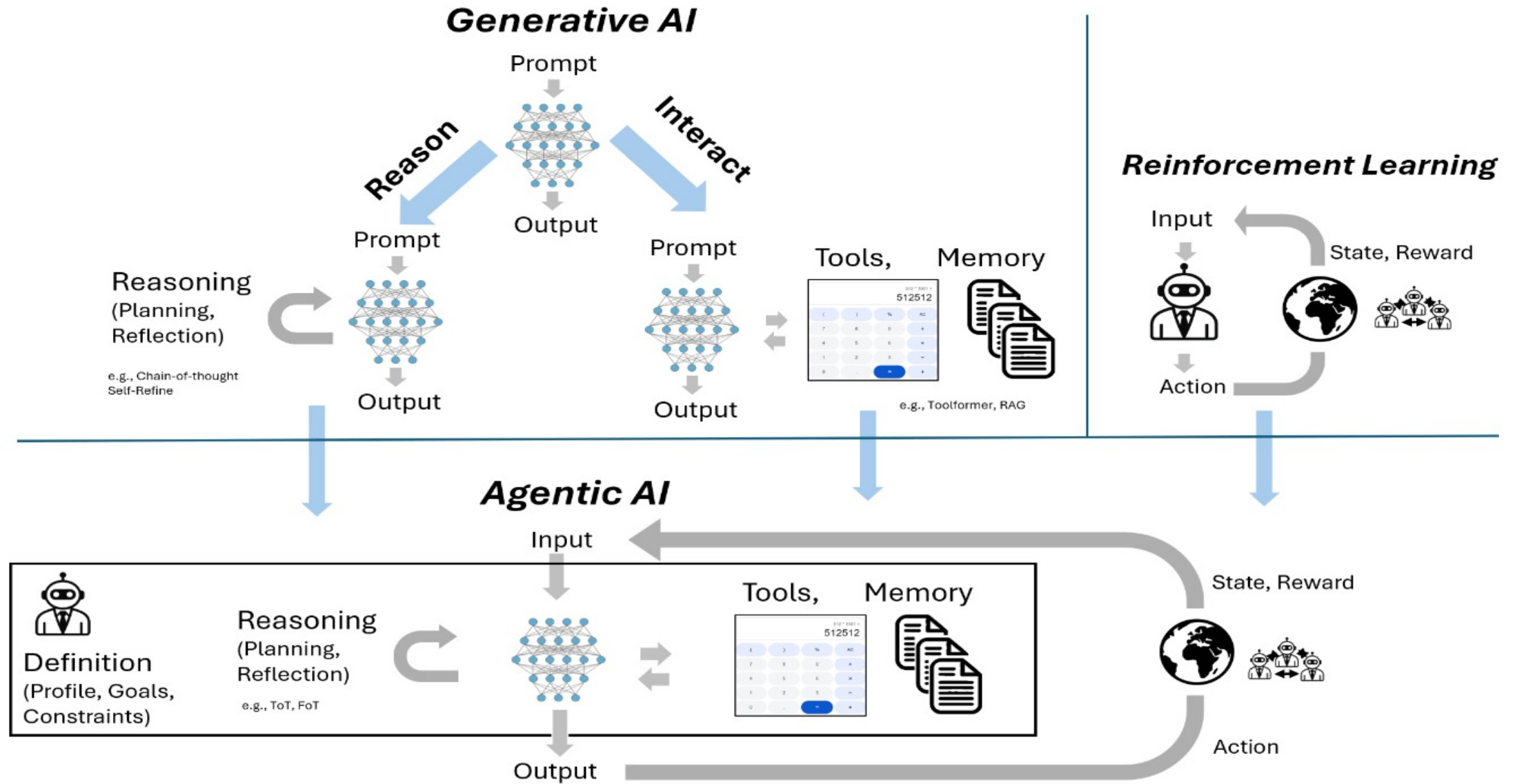

# Agentic AI and World Model for Edge General Intelligence

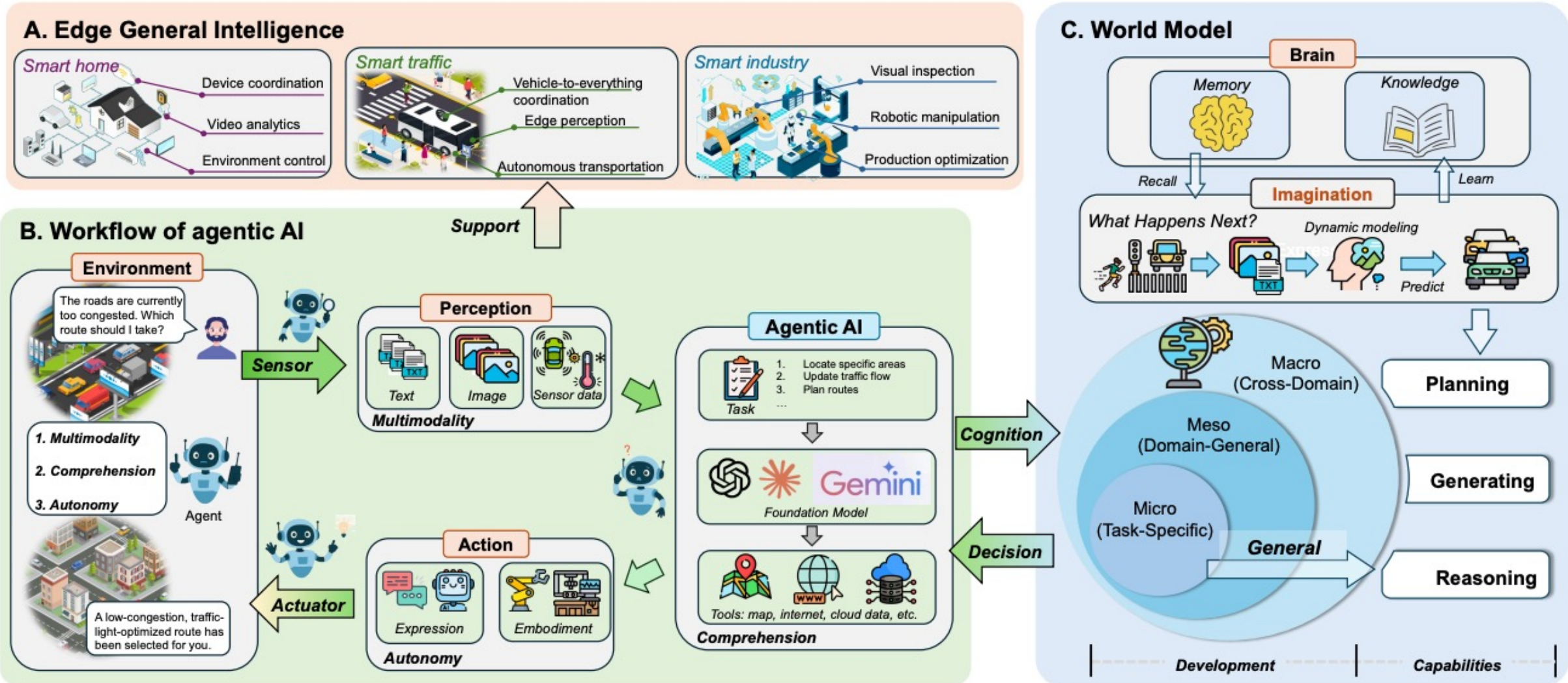

# AI Innovations for Net-Zero Transformation

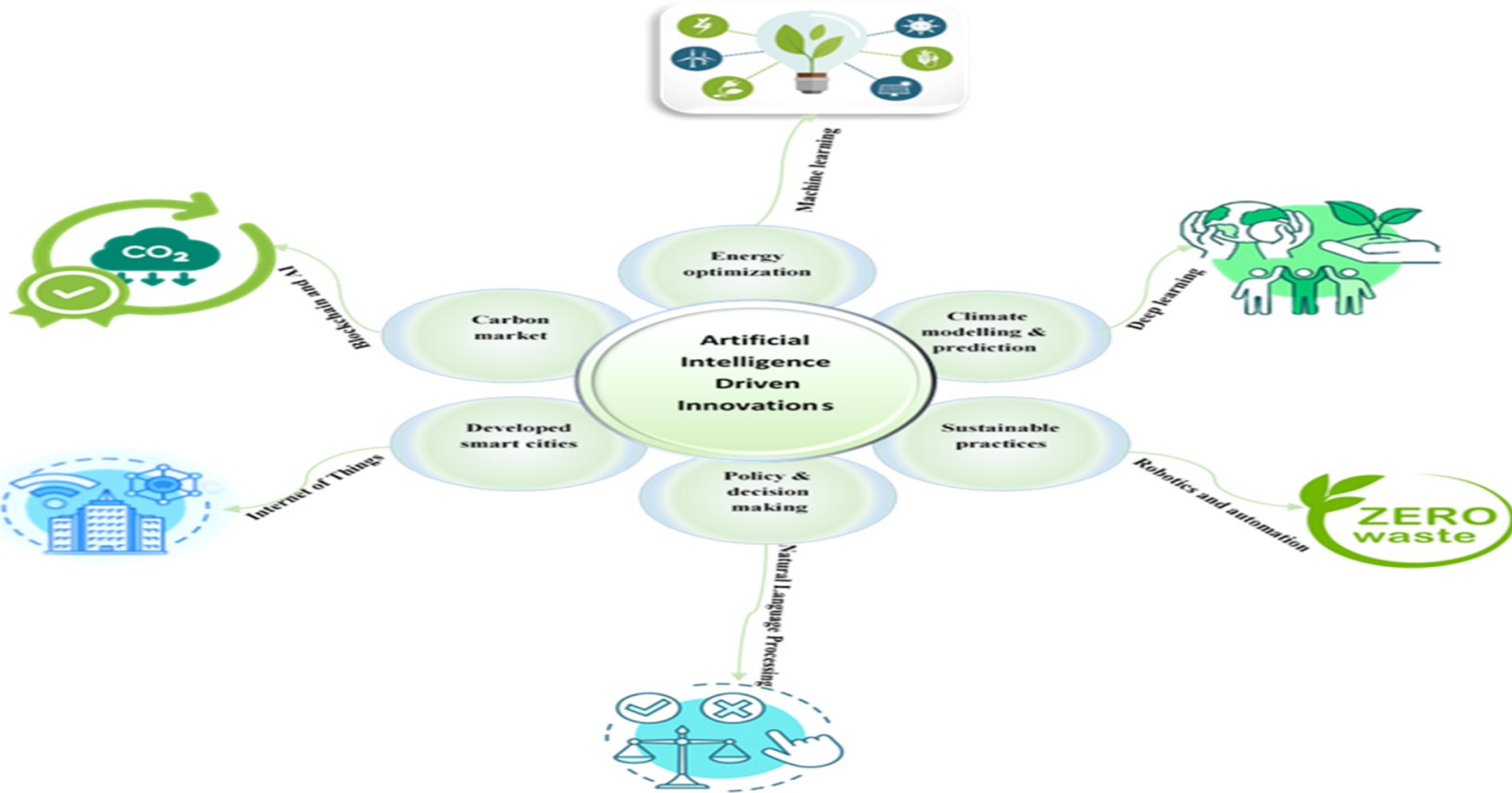

Source: Olawade, D. B., Wada, O. Z., David-Olawade, A. C., Fapohunda, O., Ige, A. O., & Ling, J. (2024). Artificial intelligence potential for net zero sustainability: Current evidence and prospects. Next Sustainability, 4, 100041.

# AI Technology for Net-Zero Energy Transition

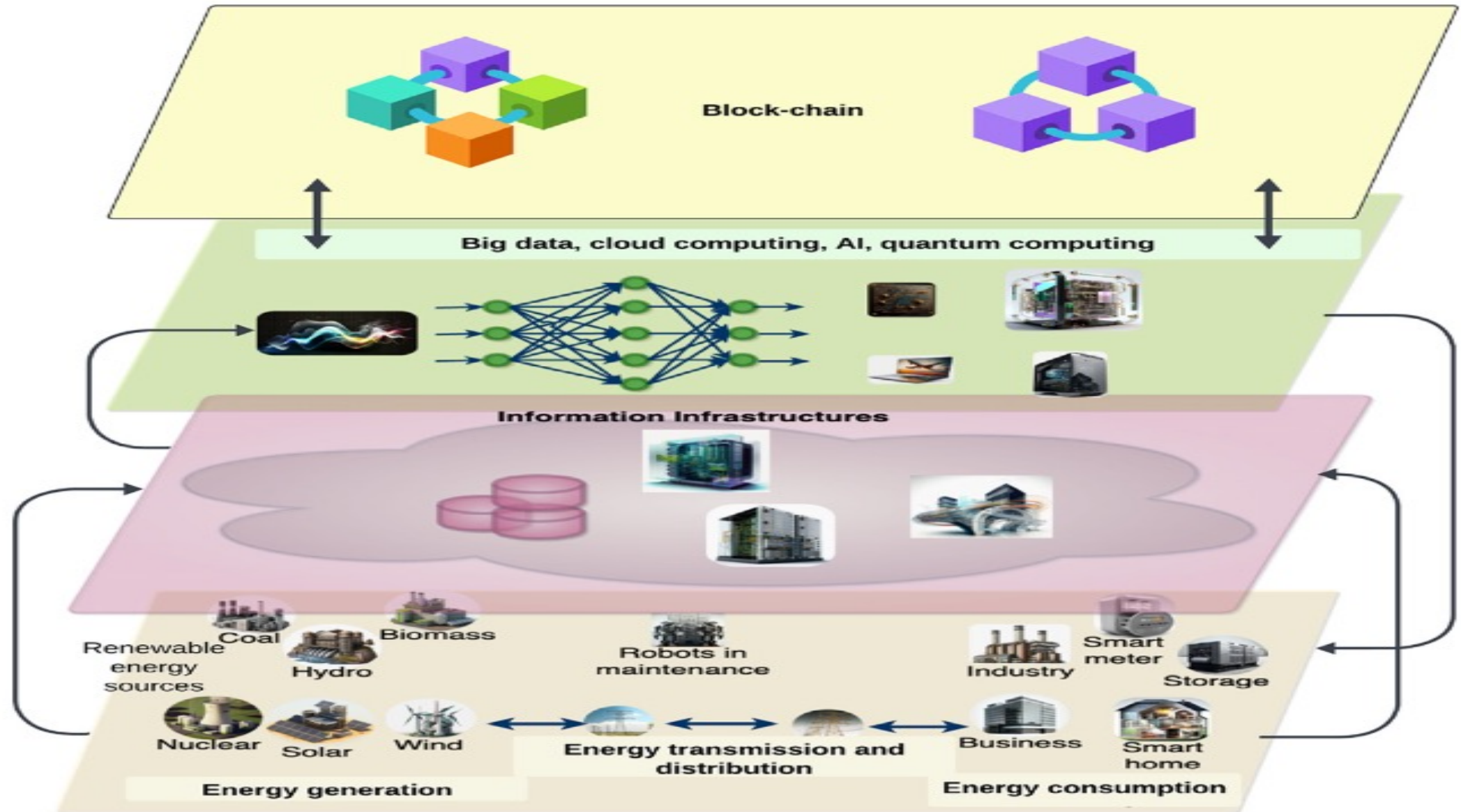

# Net-Zero Transformation

- **Ambition**

- Aligned to achieving global net zero by no later than 2050 & to limit warming to 1.5° C

- **Governance**

- Accountability driven from the top

- **Strategy**

- Embedded and aligned net zero into company strategy

- **Enterprise**

- Key operating model changes in support of transformation

- **Supply chains**

- Transformed net zero supply chains

- **Innovation**

- Developed innovation and technologies to deliver net zero

- **Finance**

- Financing the net zero transformation

- **Transparency**

- Communicating action

- **Engagement**

- Enhancing the pace and scale of net zero action

# Sustainable Productivity: Finance ESG

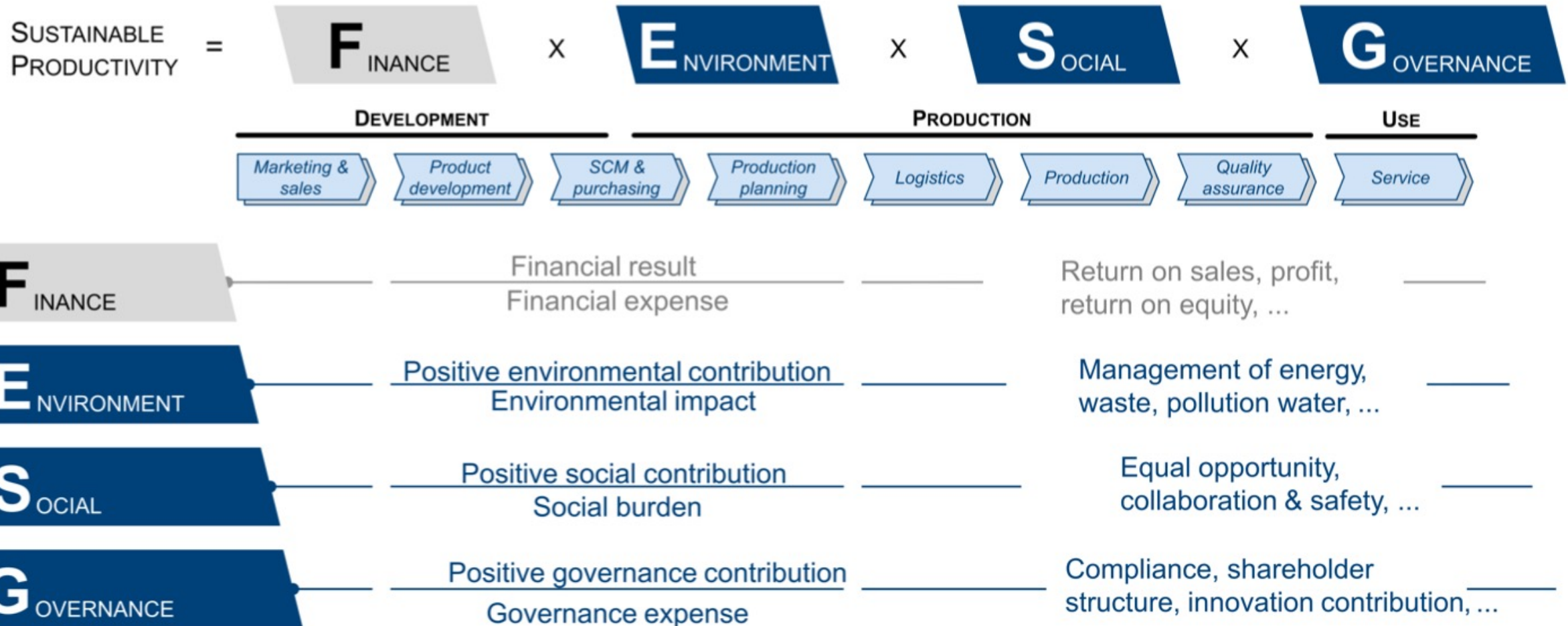

# Sustainable Resilient Manufacturing

## ESG

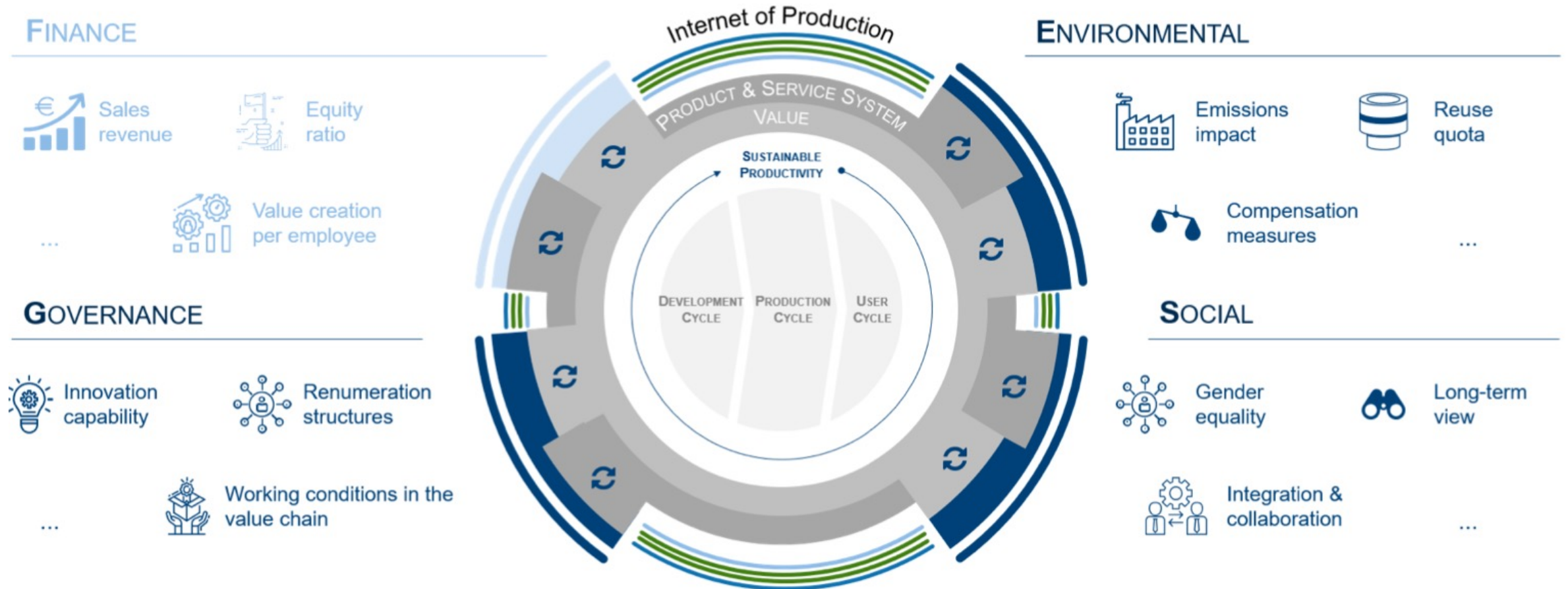

# ESG Indexes

- **MSCI ESG Index**
- **Dow Jones Sustainability Indices (DJSI)**
- **FTSE ESG Index**

# MSCI ESG Rating Framework

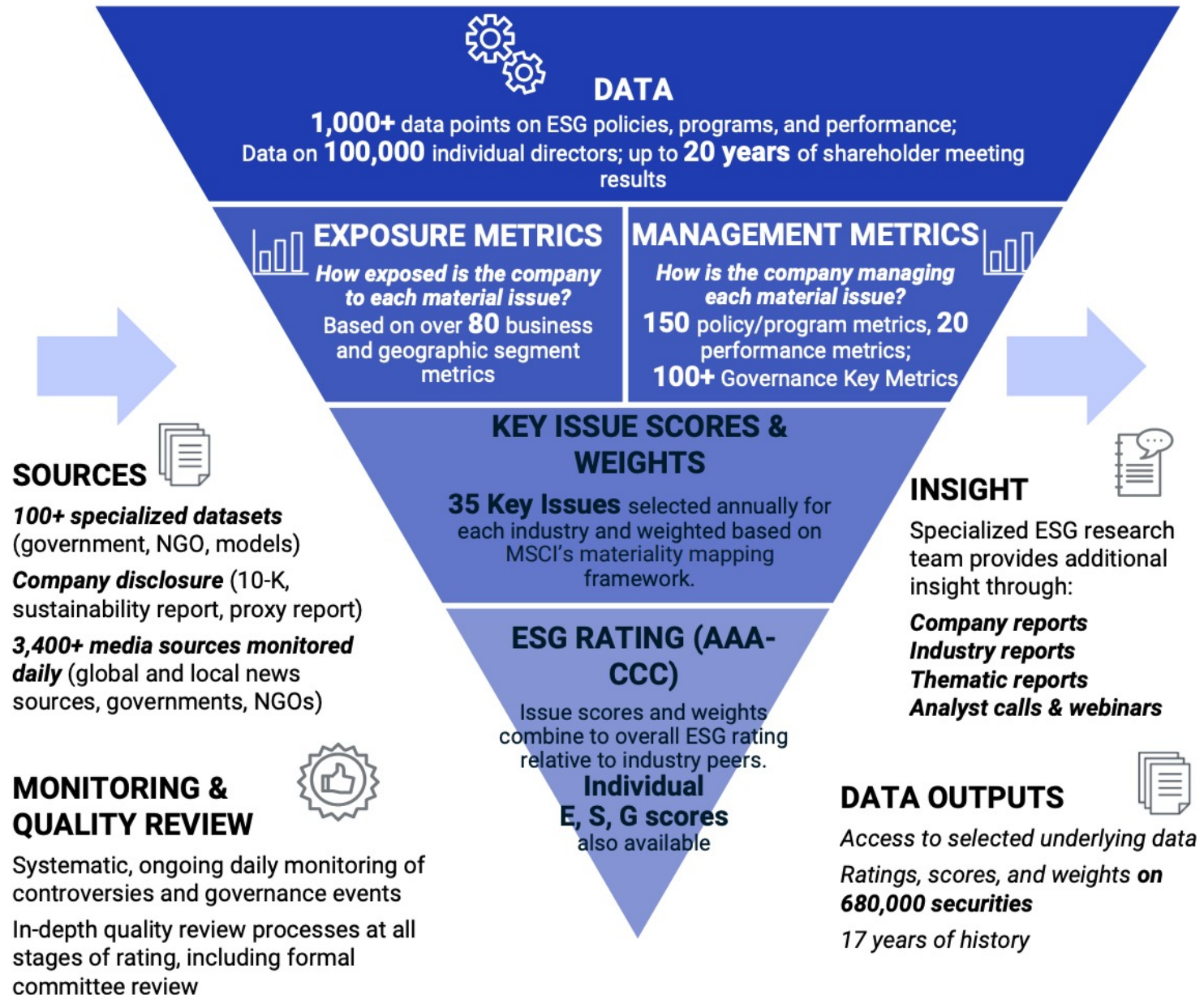

# MSCI ESG Key Issue Hierarchy

3 Pillars	10 Themes	35 ESG Key Issues	
<b>Environment</b>	<b>Climate Change</b>	Carbon Emissions Product Carbon Footprint	Financing Environmental Impact Climate Change Vulnerability
	<b>Natural Capital</b>	Water Stress Biodiversity & Land Use	Raw Material Sourcing
	<b>Pollution &amp; Waste</b>	Toxic Emissions & Waste Packaging Material & Waste	Electronic Waste
	<b>Environmental Opportunities</b>	Opportunities in Clean Tech Opportunities in Green Building	Opportunities in Renewable Energy
<b>Social</b>	<b>Human Capital</b>	Labor Management Health & Safety	Human Capital Development Supply Chain Labor Standards
	<b>Product Liability</b>	Product Safety & Quality Chemical Safety Consumer Financial Protection	Privacy & Data Security Responsible Investment Health & Demographic Risk
	<b>Stakeholder Opposition</b>	Controversial Sourcing Community Relations	
	<b>Social Opportunities</b>	Access to Communications Access to Finance	Access to Health Care Opportunities in Nutrition & Health
<b>Governance</b>	<b>Corporate Governance</b>	Ownership & Control Board	Pay Accounting
	<b>Corporate Behavior</b>	Business Ethics Tax Transparency	

# MSCI Governance Model Structure

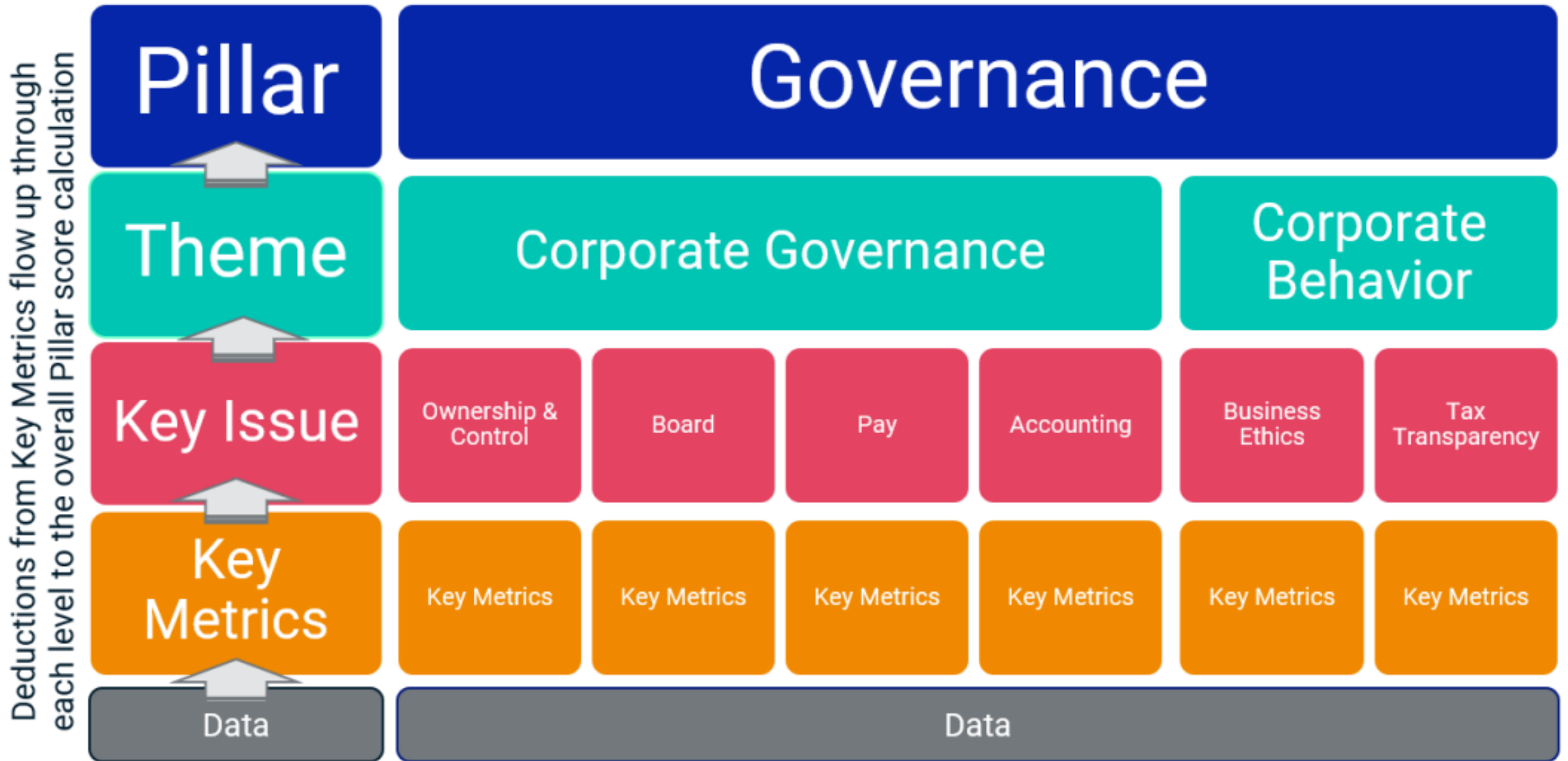

# MSCI Hierarchy of ESG Scores

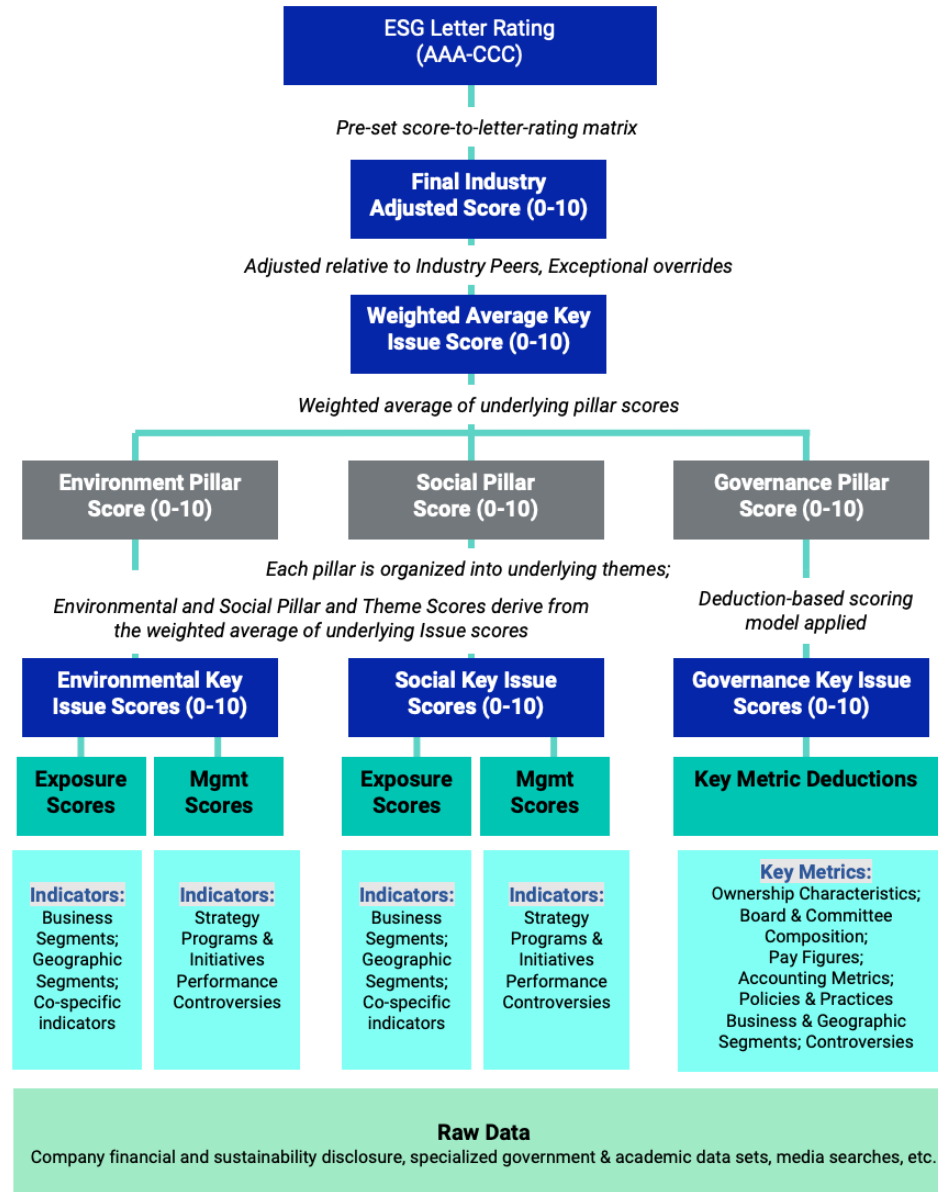

# DJSI S&P Global ESG Score

**8,000**  
Companies

**90%**  
Global market capitalization

**340,000+**  
Current Research Universe and Active Securities

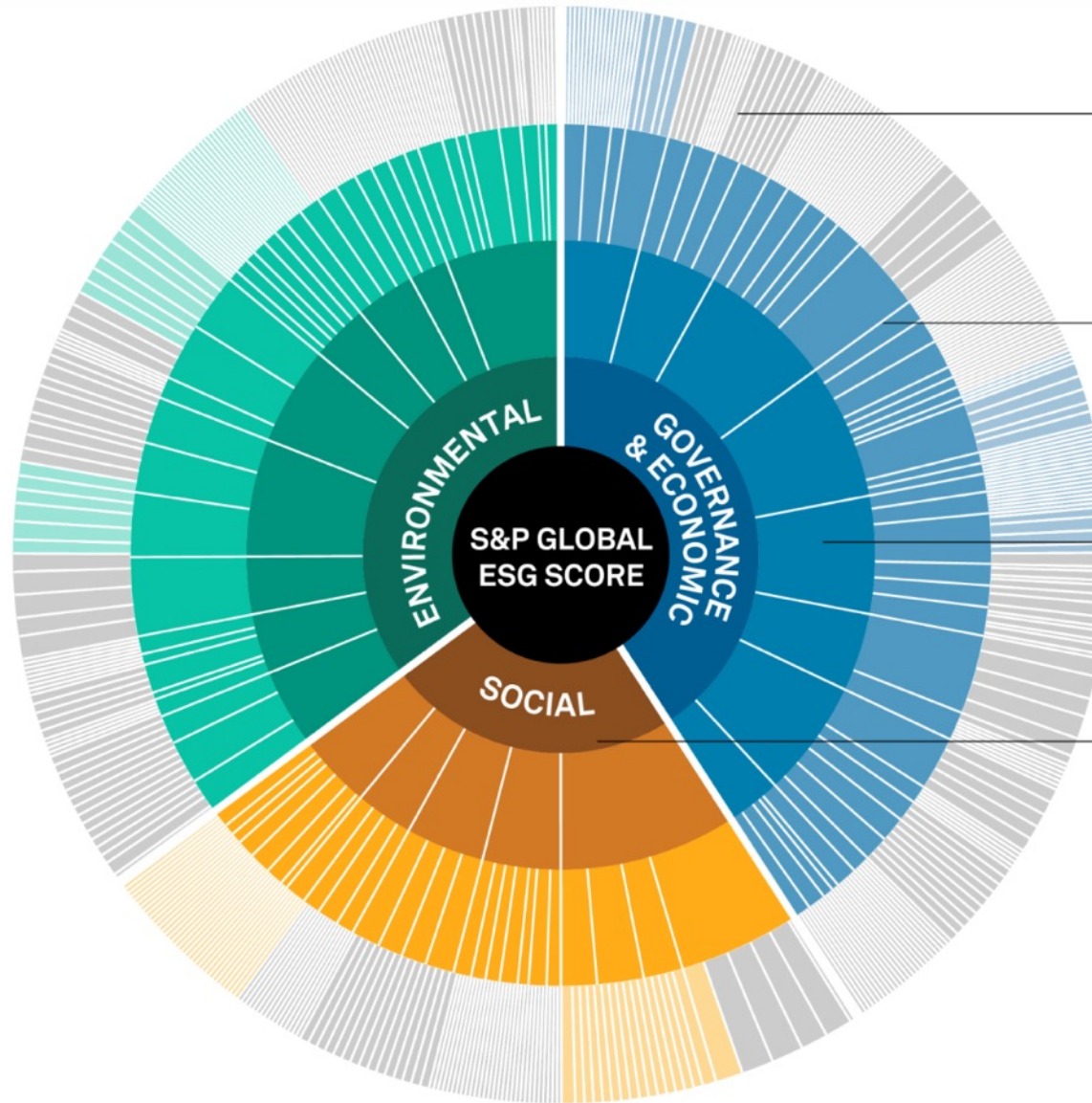

Approx.  
**1,000**  
Datapoints

**Assessed values, text, checkboxes, documents**  
Sources: Web-based questionnaire and company documents

**130+**  
Questions

**Weighted data point scores**  
Up to 50% industry-specific

Ave.  
**30+**  
Criteria scores

**Weighted question scores**  
61 industry specific approaches, with tailored questions, criteria and related weightings

**3**  
Dimension scores

**Weighted criteria scores**  
Adjusted for corporate ESG controversies where applicable

**1**

**S&P Global ESG Score**

**Sum of weighted dimension scores**

# FTSE Russell ESG Ratings



# Sustainalytics

## ESG Risk Ratings

Analyst-based  
approach

Sustainalytics' ESG Risk Ratings measure a company's exposure to industry-specific material ESG risks and how well a company is managing those risks.

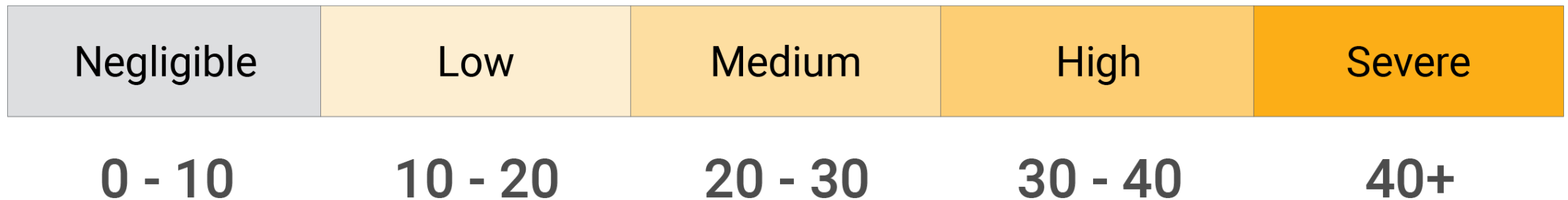

# Truvalue ESG Ranks

Machine-based  
approach

- **Truvalue Labs** applies **AI** to analyze over **100,000 sources** and uncover **ESG risks** and opportunities hidden in **unstructured text**.
- The ESG Ranks data service produces an overall company rank based on industry percentile leveraging the **26 ESG categories** defined by the **Sustainability Accounting Standards Board (SASB)**.
- The data feed covers **20,000+** companies with more than **13 years** of history.

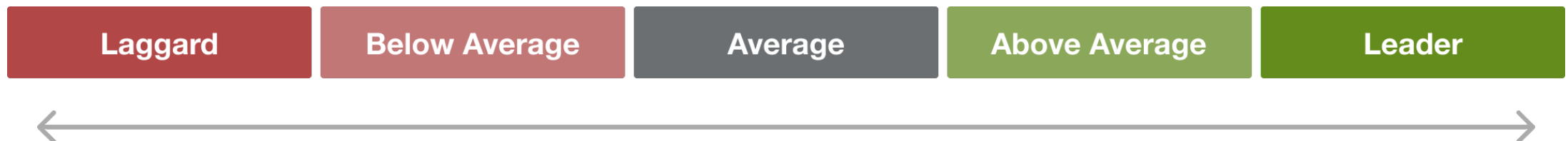

# Analyst-driven vs. AI-driven ESG

## Analyst-driven ESG research

Derives ratings in a structured data model

## Sustainalytics



*Analyst role at the end of the process allows subjectivity to color results*

## AI-driven ESG research

Derives signals from unstructured data

## Truvalue Labs



*Analyst expertise at the beginning of the process produces consistent results*

# Analyst based ESG Research

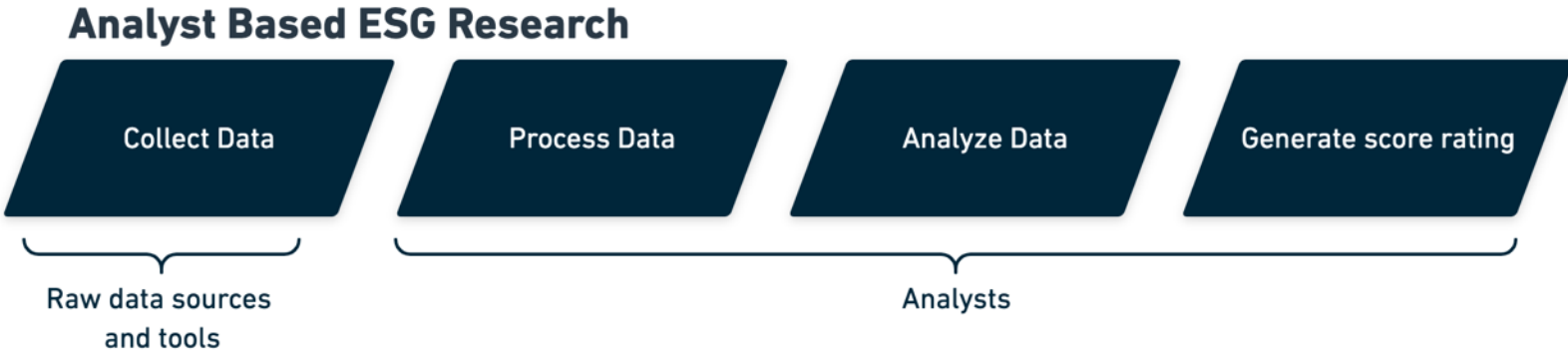

# AI based ESG Research

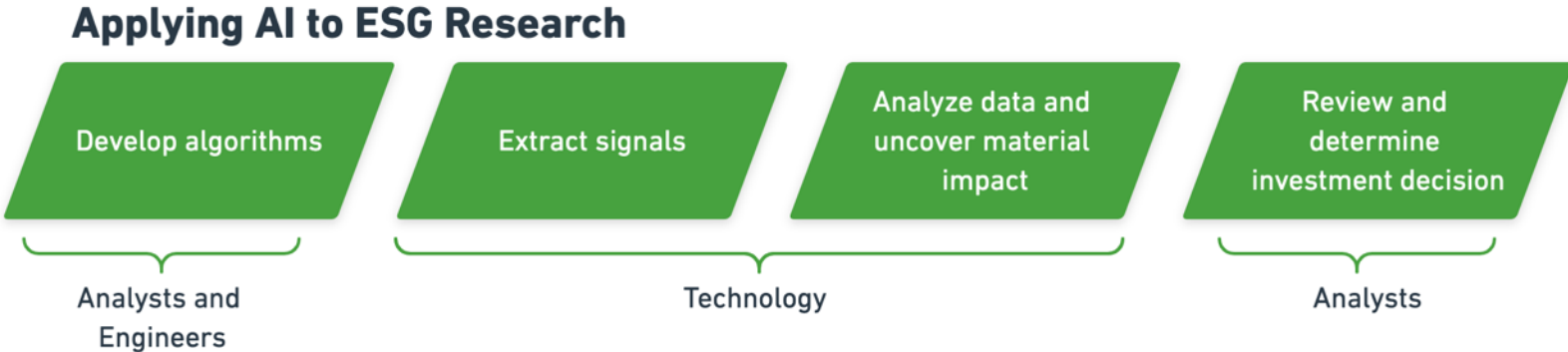

**It would take an analyst over 5 years to do what our AI can in 1 week**  
Combining analysts with AI creates gives you the full picture

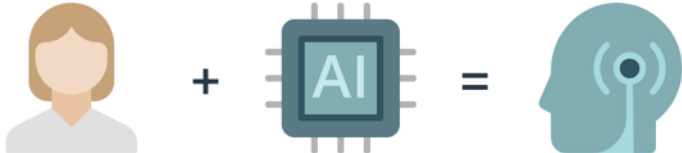

**ESG ANALYTICS**  
Invest where it matters.

# ESG Analytics: NLP Taxonomy

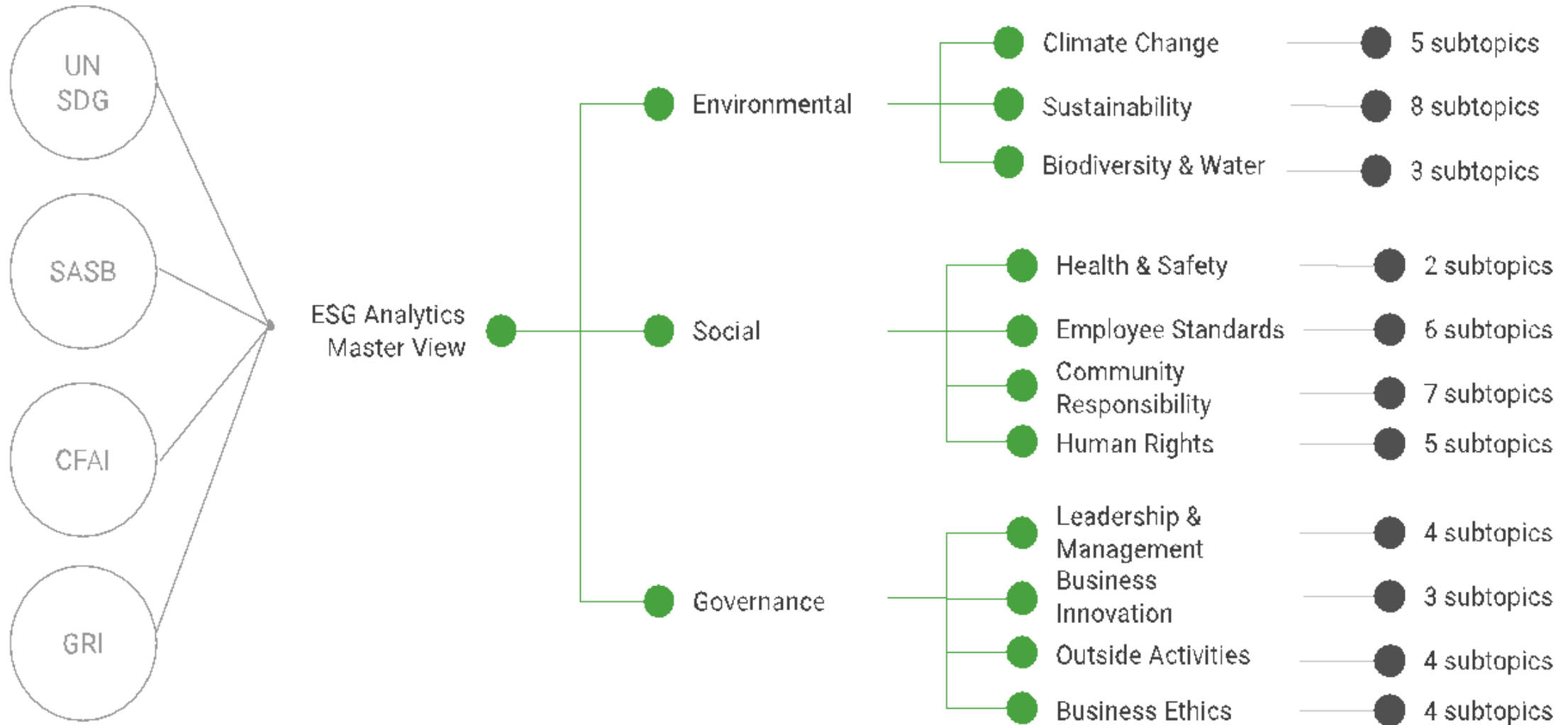



# Four Paradigms in NLP (LM)

Paradigm	Engineering	Task Relation
a. Fully Supervised Learning (Non-Neural Network)	Feature (e.g. word identity, part-of-speech, sentence length)	
b. Fully Supervised Learning (Neural Network)	Architecture (e.g. convolutional, recurrent, self-attentional)	
<b>Transfer Learning: Pre-training, Fine-Tuning (FT)</b>		
c. Pre-train, Fine-tune	Objective (e.g. masked language modeling, next sentence prediction)	
<b>GAI: Pre-train, Prompt, and Predict (Prompting)</b>		
d. Pre-train, Prompt, Predict	Prompt (e.g. cloze, prefix)	

# Comparison of Generative AI and Traditional AI

<b>Feature</b>	<b>Generative AI</b>	<b>Traditional AI</b>
Output type	New content	Classification/Prediction
Creativity	High	Low
Interactivity	Usually more natural	Limited

# Multimodal Large Language Models (MLLM)

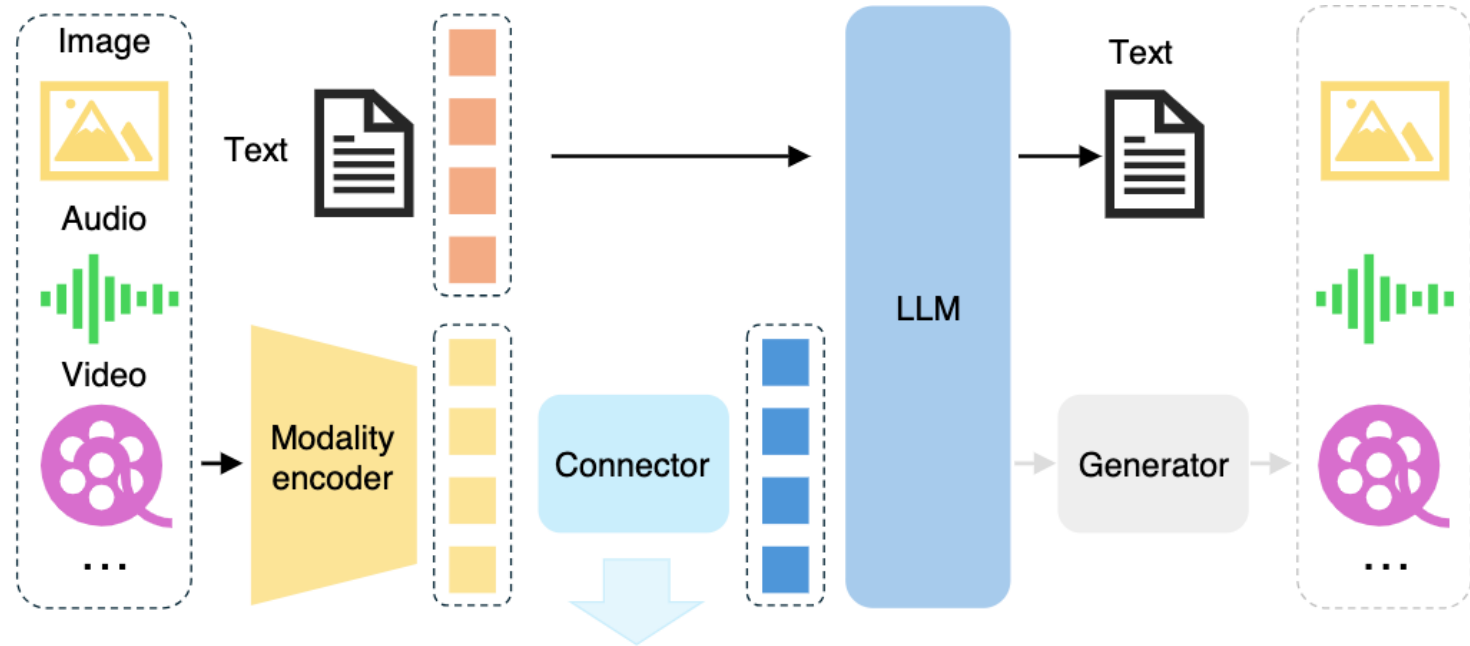

## Multimodal LLM

Three types of connectors:

1. projection-based
2. query-based
3. fusion-based connectors

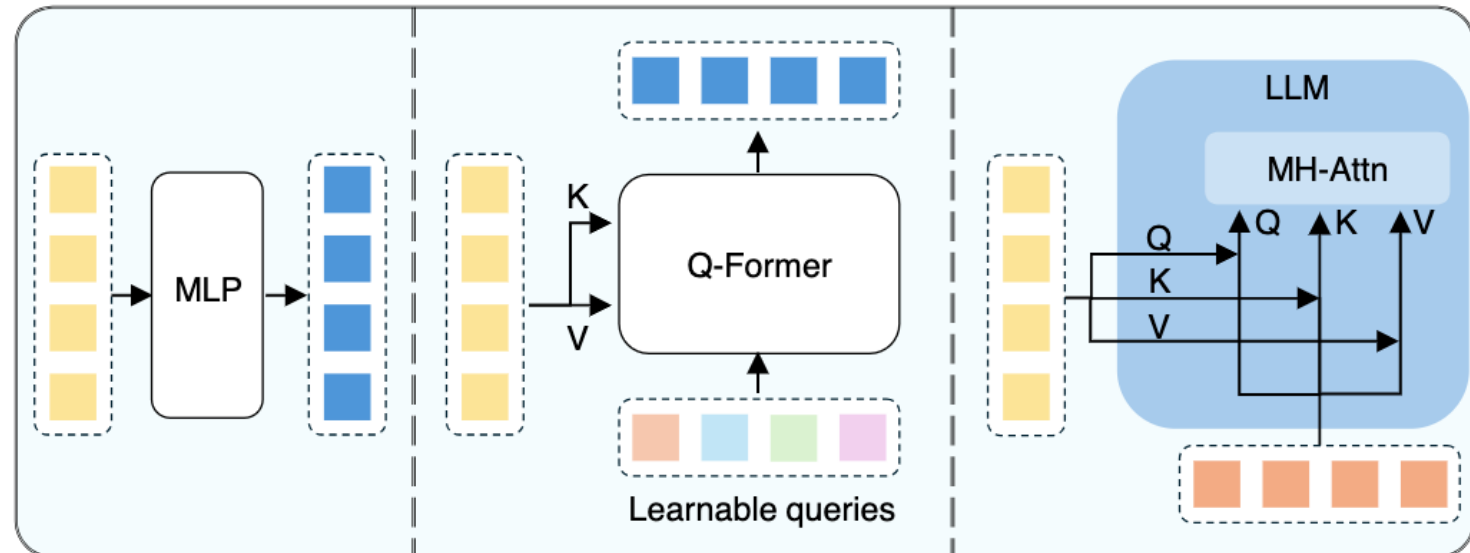

# Multimodal Large Language Model (MLLM) for Vision Question Answering

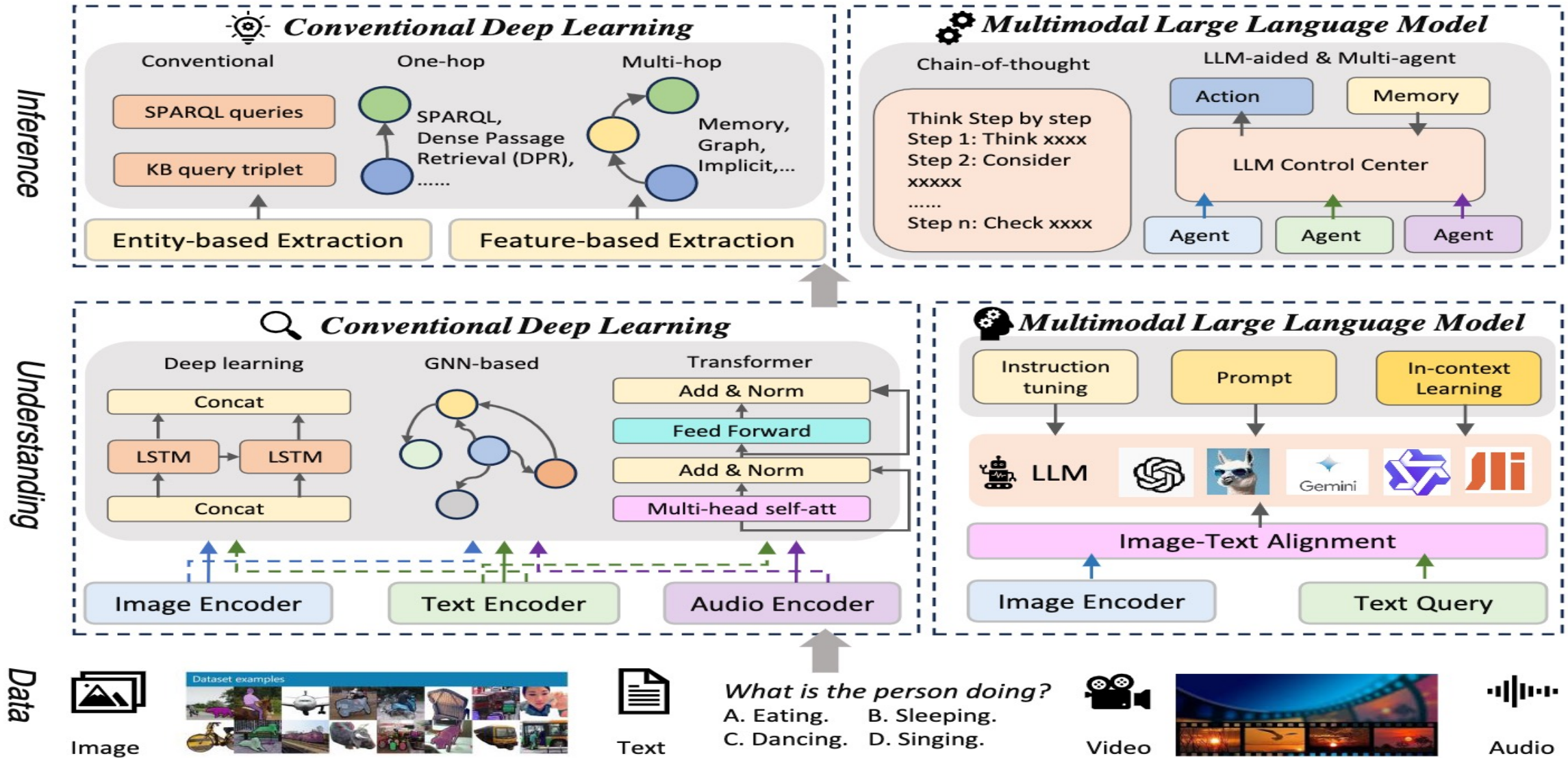





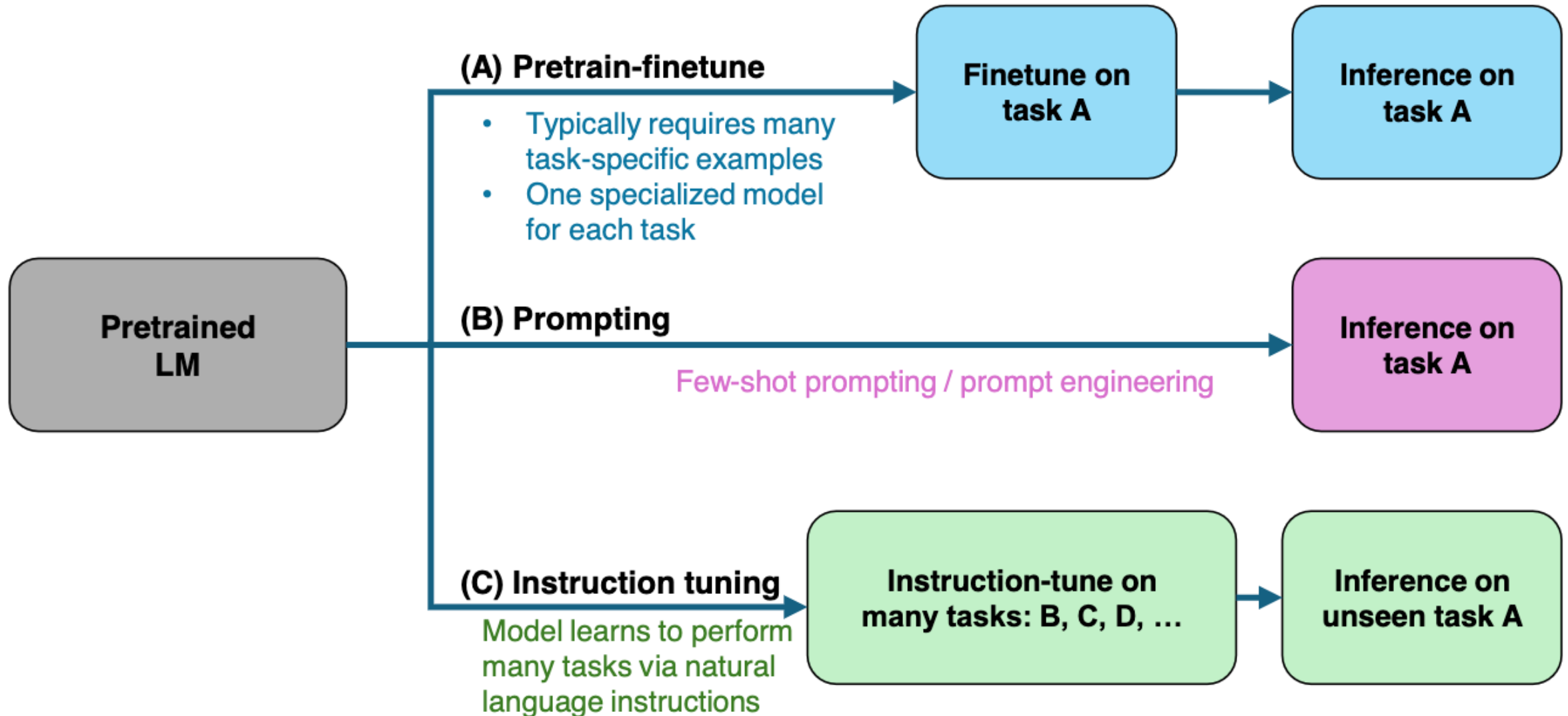





# Large Language Models (LLM)

## Three typical learning paradigms



# LMarena Leaderboard

Rank (UB) ↑	Model ↑↓	Score ↑↓	95% CI (±) ↑↓	Votes ↑↓	Organization ↑↓	License ↑↓
1	 gemini-2.5-pro	1455	±5	41,731	Google	Proprietary
1	 claude-opus-4-1-20250805-thinking-16k	1451	±6	11,750	Anthropic	Proprietary
2	 o3-2025-04-16	1444	±4	43,898	OpenAI	Proprietary
2	 gpt-5-high	1442	±6	15,076	OpenAI	Proprietary
2	 chatgpt-4o-latest-20250326	1441	±4	36,426	OpenAI	Proprietary
3	 gpt-4.5-preview-2025-02-27	1439	±6	15,271	OpenAI	Proprietary
3	 claude-opus-4-1-20250805	1438	±6	18,341	Anthropic	Proprietary
5	 gpt-5-chat	1430	±6	11,808	OpenAI	Proprietary
6	 qwen3-max-preview	1428	±7	8,781	Alibaba	Proprietary
8	 grok-4-0709	1422	±5	21,446	xAI	Proprietary

<https://lmarena.ai/>

# LMarena Leaderboard

Model	Overall	Hard Prompts	Coding	Math	Creative Writing	Instruction Following	Longer Query	Multi-Turn
claude-opus-4-1-...	1	1	1	1	1	1	1	1
gemini-2.5-pro	1	2	3	1	1	1	1	1
chatgpt-4o-lates...	2	4	3	13	2	5	4	1
gpt-5-high	2	2	3	1	7	5	11	6
o3-2025-04-16	2	4	3	1	8	6	13	7
claude-opus-4-1-...	3	2	1	1	1	1	1	1
gpt-4.5-preview-...	3	5	4	8	1	4	3	1
gpt-5-chat	5	3	3	8	3	5	3	1
qwen3-max-preview	6	4	2	1	7	4	4	3
claude-opus-4-20...	8	4	3	6	2	2	2	7
deepseek-r1-0528	8	8	4	10	8	15	13	14
deepseek-v3.1	8	6	4	1	7	6	5	9
deepseek-v3.1-th...	8	4	3	1	2	4	1	7
grok-4-0709	8	10	12	1	4	6	8	7
kimi-k2-0711-pre...	8	10	7	13	16	24	22	7
kimi-k2-0905-pre...	8	5	3	-	6	16	12	7
qwen3-235b-a22b-...	8	4	3	2	9	6	4	7
glm-4.5	10	7	4	7	14	7	8	10

# Artificial Analysis Intelligence Index

## Intelligence, Speed, Price

### INTELLIGENCE

Artificial Analysis Intelligence Index; Higher is better

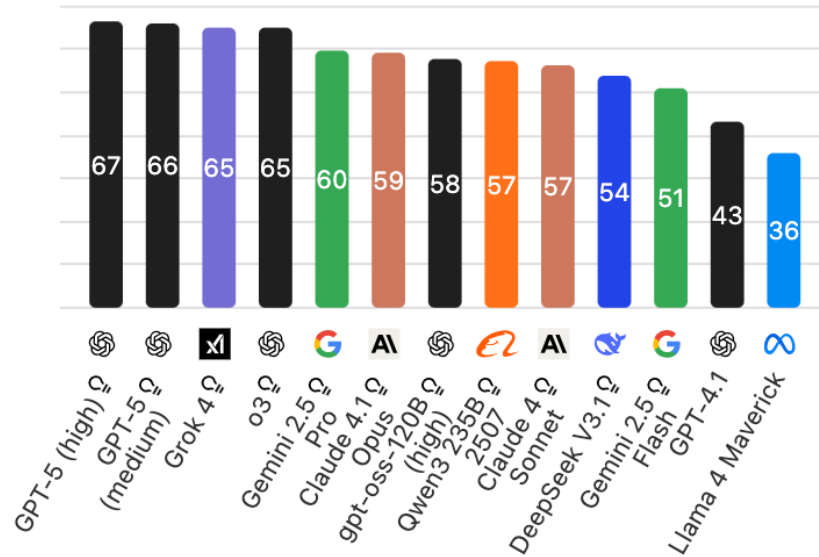

### SPEED

Output Tokens per Second; Higher is better

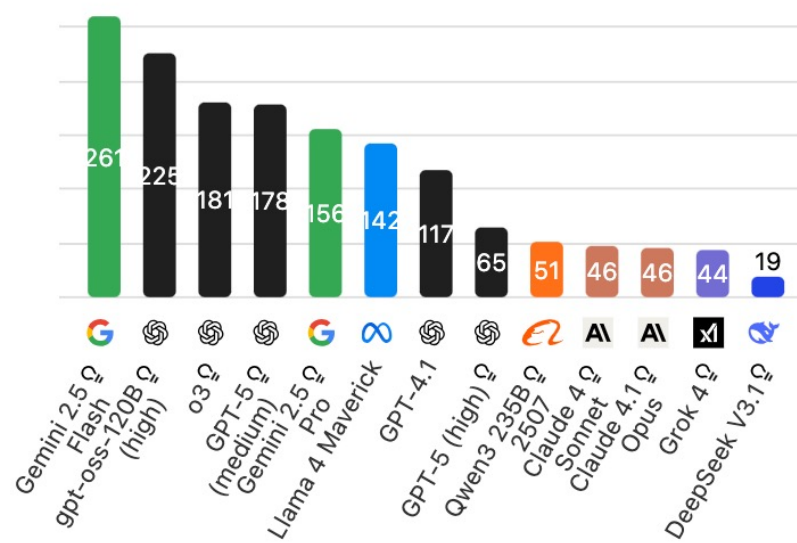

### PRICE

USD per 1M Tokens; Lower is better

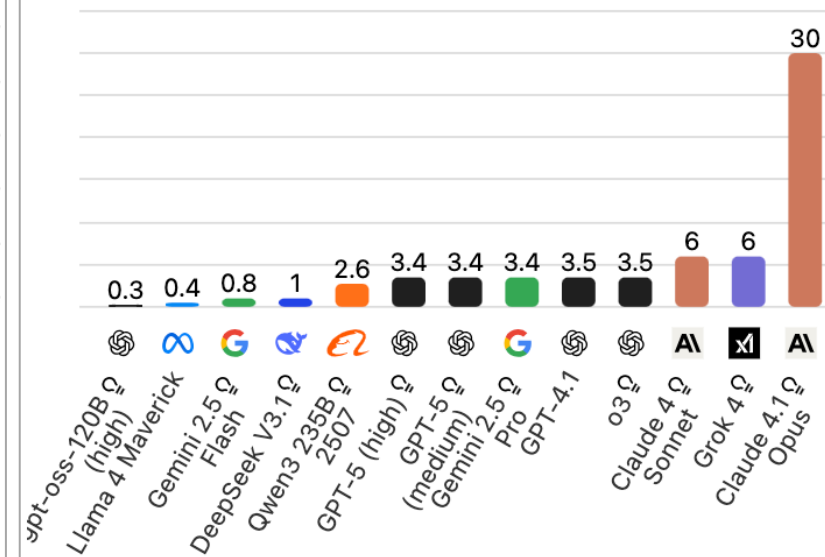

# Artificial Analysis Intelligence Index 2022-2025

## Frontier Language Model Intelligence, Over Time

Artificial Analysis Intelligence Index v3.0 incorporates 10 evaluations: MMLU-Pro, GPQA Diamond, Humanity's Last Exam, LiveCodeBench, SciCode, AIME 2025, IFBench, AA-  
LCR, Terminal-Bench Hard,  $\tau^2$ -Bench Telecom

Alibaba Anthropic DeepSeek Google LG AI Research Meta Mistral Moonshot AI OpenAI Upstage xAI Z AI

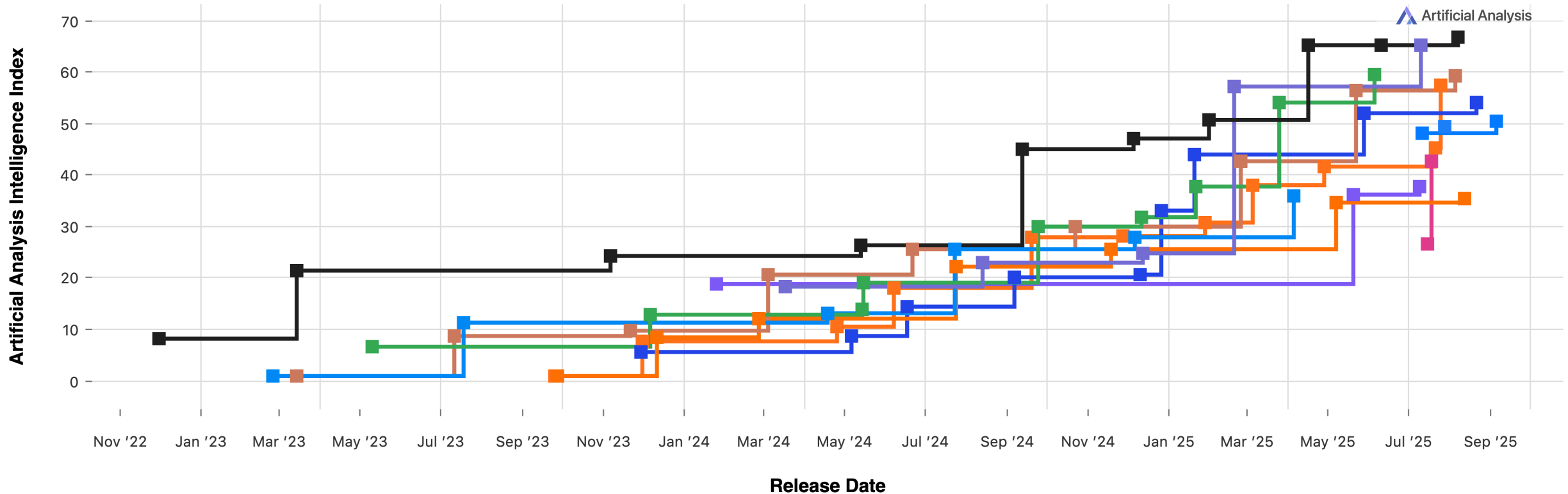

# Google Gemma 3 27B

The most capable model you can run on a single GPU or TPU

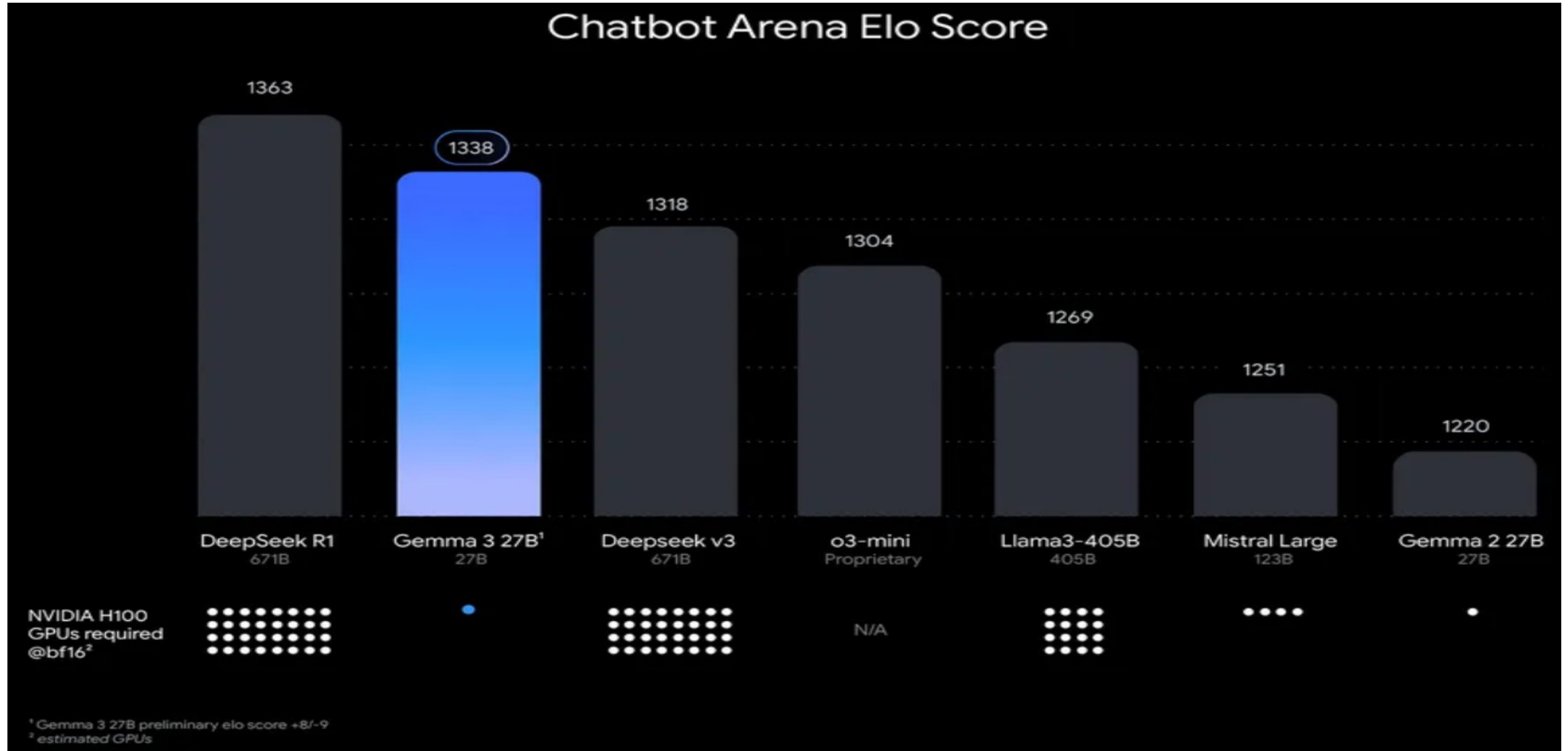

Source: <https://blog.google/technology/developers/gemma-3/>

# Google Gemma 3 Multimodality (vision-language input and text outputs)

MODEL	SIZE (in billion parameter)	CONTEXT LENGTH	LANGUAGES	INPUT MODALITIES
Gemma 3 1B (IT)	1B	32k	English	Input: Text Output: Text
Gemma 3 4B (IT)	4B	128k	+140 Languages	Input: Text, Image Output: Text
Gemma 3 12B (IT)	12B	128k	+140 Languages	Input: Text, Image Output: Text
Gemma 3 27B (IT)	27B	128k	+140 Languages	Input: Text, Image Output: Text
Shield Gemma 2	4B	8k	+140 Languages	Input: Text, Image Output: Text

# Google Gemma 3: Pre-training and Post-training (distillation, reinforcement learning, and model merging)

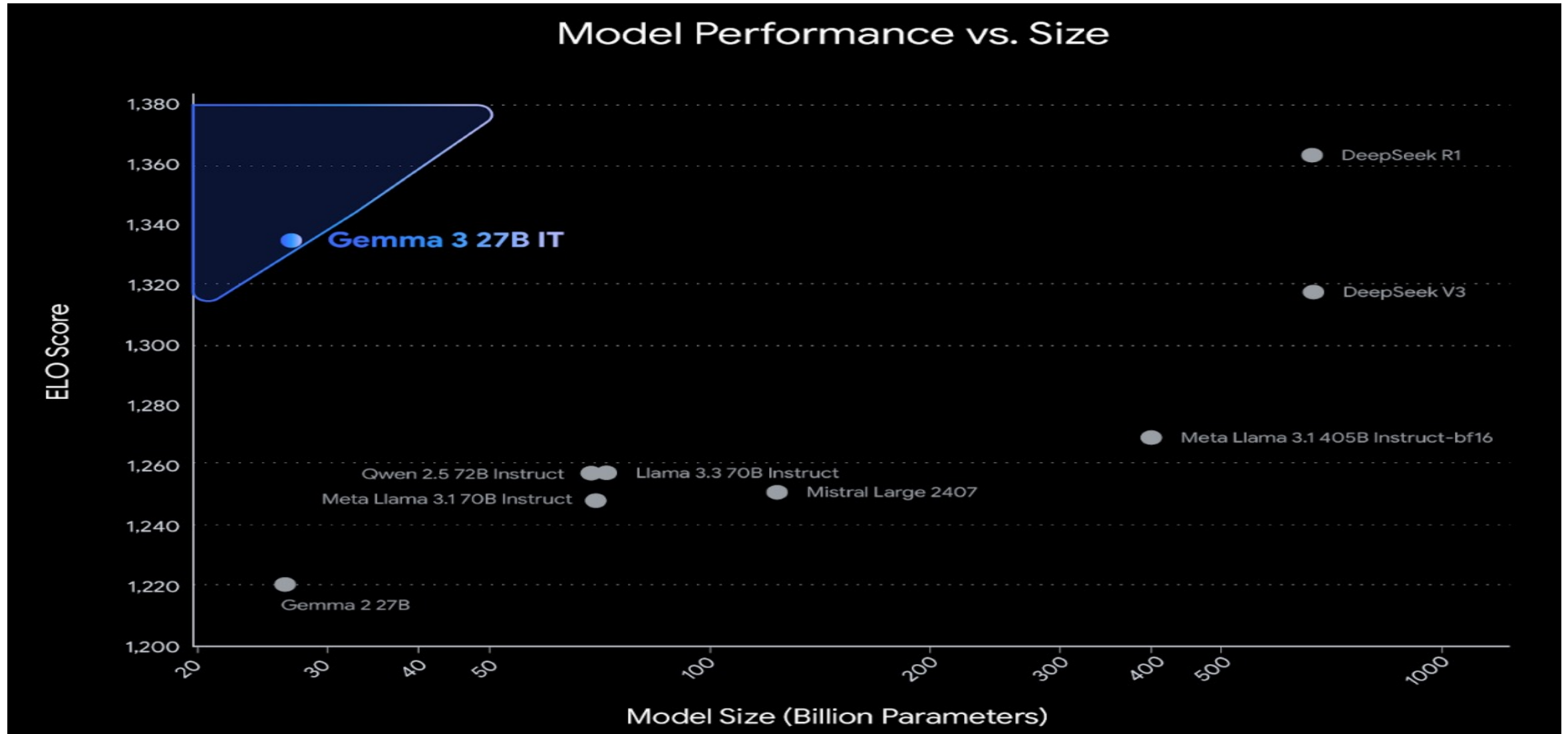

Source: <https://developers.googleblog.com/en/introducing-gemma3/>

# Google AI Studio (Gemma 3 27B)

The screenshot displays the Google AI Studio interface. At the top, the title bar reads "Generative AI: A Comprehensive Over..." with various utility icons like "Enable Autosave", "Compare", "Open in Kaggle", and "Open in Vertex AI". The left sidebar contains navigation options such as "Get API key", "Create Prompt", "Stream Realtime", "Starter Apps", "Tune a Model", "Library", "Enable chat history", "Prompt Gallery", "Developer documentation", "Developer forum", and "Changelog". The main content area features a text input field with a "Generative AI" button. Below the input, the title "Generative AI: A Deep Dive" is followed by an introductory paragraph and a section titled "1. What is Generative AI?". This section defines generative AI as a machine learning category that creates new content and lists key characteristics: learning patterns, generating novel content, being probabilistic, and requiring large datasets. The right sidebar shows "Run settings" for the "Gemma 3 27B" model, including a token count of 1,760 / 131,072, a temperature slider set to 1, and an "Advanced settings" section with "Safety settings" and "Add stop sequence" options. The bottom of the interface includes a "Type something" input field and a "Run" button.

Google AI Studio

Generative AI: A Comprehensive Over... Enable Autosave Compare Open in Kaggle Open in Vertex AI

Get API key

Create Prompt

Stream Realtime

Starter Apps

Tune a Model

Library

Enable chat history

Prompt Gallery

Developer documentation

Developer forum

Changelog **NEW**

Gemma models may make mistakes, so double-check its response. Gemma is provided under and subject to the Gemma Terms of Use.

Settings

Generative AI

## Generative AI: A Deep Dive

Generative AI is one of the most exciting and rapidly evolving fields in artificial intelligence right now. Here's a comprehensive overview, covering what it is, how it works, its types, applications, limitations, and future trends:

### 1. What is Generative AI?

Generative AI refers to a category of machine learning models that can **create new content** – text, images, audio, video, code, and more – that resembles the data they were trained on. Unlike traditional AI which *analyzes* or *acts* on existing data, generative AI *produces* new data. Think of it as AI that can "imagine" and then manifest those imaginations.

**Key Characteristics:**

- **Learns Patterns:** Generative AI models learn the underlying patterns and structures within a dataset.
- **Generates Novel Content:** They use this learned knowledge to create new, original content that wasn't explicitly present in the training data.
- **Probabilistic:** Generation isn't deterministic. The models predict probabilities, leading to variations in output even with the same input.
- **Requires Large Datasets:** Effective generative AI typically needs massive amounts of data for training.

2. How Does it Work? (The Core Technology)

Type something

Run

### Run settings

Get code

Model

Gemma 3 27B

Token count

1,760 / 131,072

Temperature

1

Advanced settings

Safety settings

Edit safety settings

Add stop sequence

Add stop...

Output length

8192

# Grok 3 Deep Search

The screenshot displays the Grok 3 Deep Search interface. At the top left is the Grok logo. On the top right, there are icons for editing, sharing, and a search filter set to 'Generative AI'. A vertical progress bar on the left shows the search stages: Completed (49s · 71 Sources), Thinking, Exploring user intent (current), Researching recent developments, and Investigating healthcare applications. The main content area shows the 'Exploring user intent' step, where the system analyzes the request 'Generative AI' and searches for a 'definition of generative AI'. It lists 10 results found, including links to Wikipedia, NVIDIA, IBM Research, AWS, and MIT News. A 'Browsing results' section is also visible, showing the current step of looking for a definition from the search results. At the bottom, there is a text input field with the placeholder 'How can Grok help?' and buttons for 'DeepSearch' and 'Think'. The Grok 3 logo and an upward arrow are also present.

# Perplexity.ai Deep Research

The screenshot displays the Perplexity.ai interface. On the left is a sidebar with the Perplexity logo and navigation options: Home, Discover, Spaces, and Library. The main content area shows a 'Deep Research' thread titled 'Generative AI'. At the top of the thread, there are filters for 'Deep Research', 'Images', and 'Sources' (39), along with a '54 steps' dropdown. Below the filters are four source cards: 'linkedin' (The Future of Generative AI: Key Trends and Opportunities in...), 'ciklum' (Top 10 GenAI Trends to Watch in Technology 2025 and Beyond), 'research.aimultiple' (Top 100+ Generative AI Applications with Real-Life...), and '+36 sources'. The main text of the thread is titled 'Generative AI: Current State, Applications, and Future Trends in 2025' and begins with 'Generative AI has rapidly evolved into a transformative technology, revolutionizing content creation, business operations, and digital interactions across industries. As of early 2025, this technology has moved beyond experimental phases into mainstream adoption, with McKinsey reporting that 65% of organizations now regularly use generative AI, demonstrating its growing significance in the business landscape 4 .'. Below the text is a section titled 'Understanding Generative AI' with the start of a paragraph: 'Generative AI refers to a sophisticated branch of artificial intelligence that employs machine...'. At the bottom of the thread, there is a 'Ask follow-up' input field with a 'Deep Research' dropdown menu and a send button.

# Token

## Tiktokenizer

gpt-4o

System

You are a helpful assistant



User

Content



Add message

```
<|im_start|>system<|im_sep|>You are a helpful  
assistant<|im_end|><|im_start|>user<|im_sep|><|im_end|>  
<|im_start|>assistant<|im_sep|>
```

Token count  
16

```
<|im_start|>system<|im_sep|>You are a helpful assistan  
t<|im_end|><|im_start|>user<|im_sep|><|im_end|><|im_st  
art|>assistant<|im_sep|>
```

```
200264, 17360, 200266, 3575, 553, 261, 10297, 29186, 2  
00265, 200264, 1428, 200266, 200265, 200264, 173781, 2  
00266
```

Show whitespace

<https://tiktokenizer.vercel.app/>

# Word Embeddings

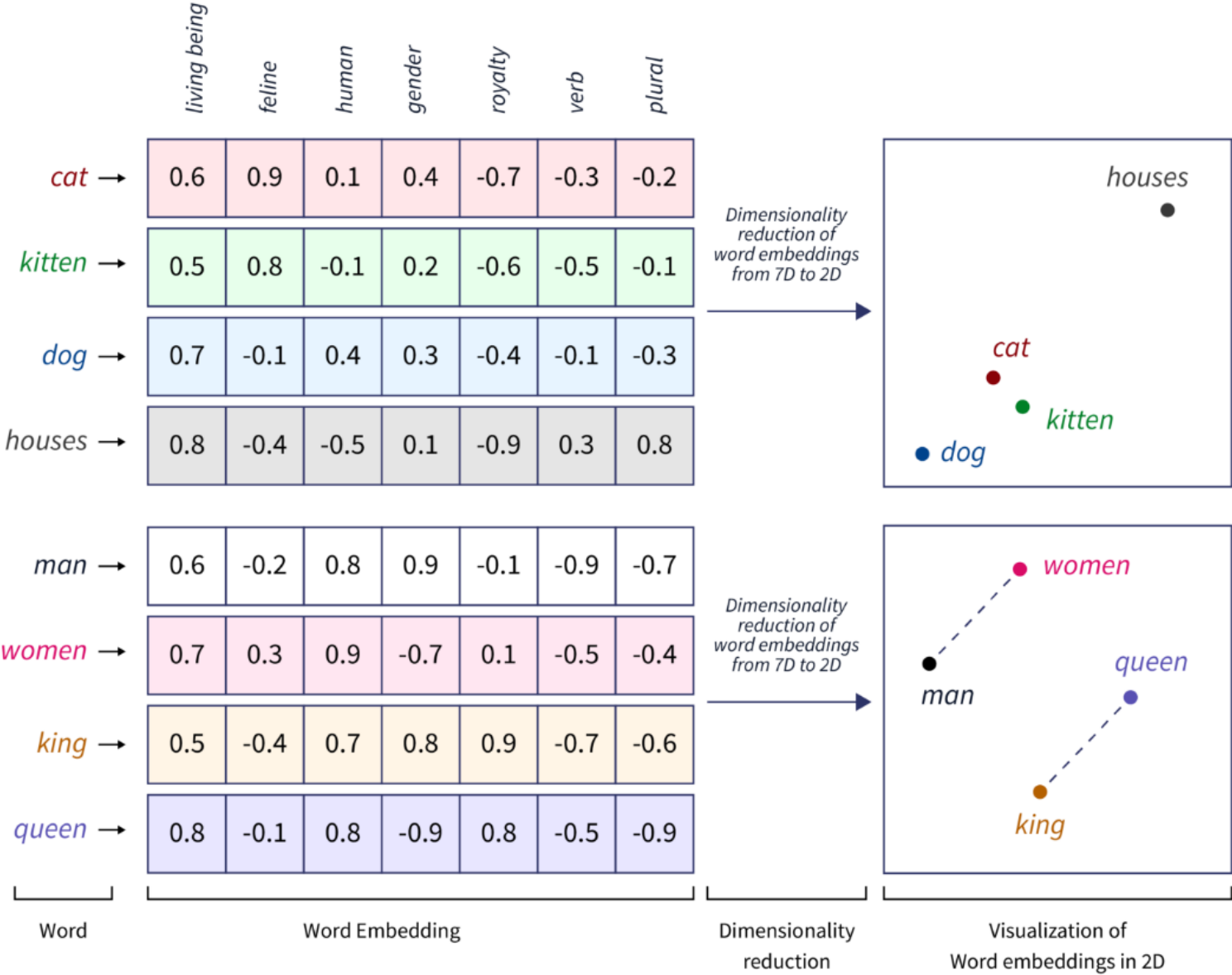

Source: <https://www.scaler.com/topics/tensorflow/tensorflow-word-embeddings/>

# Transformer (Attention is All You Need)

(Vaswani et al., 2017)

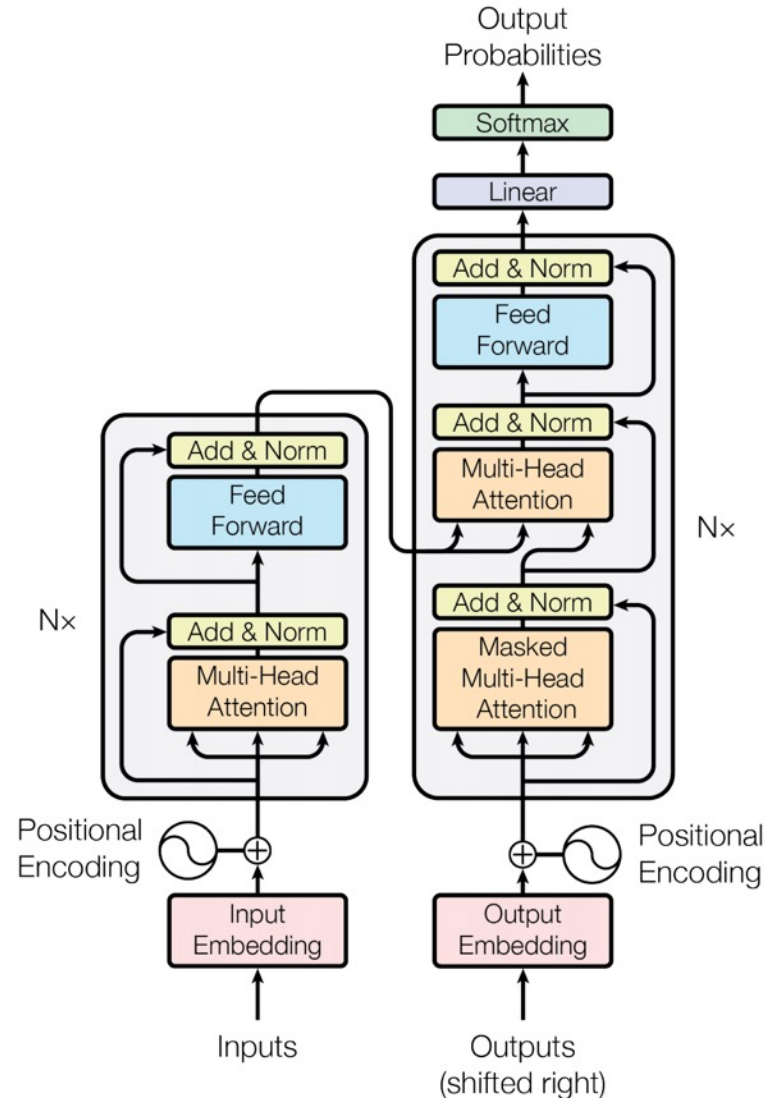

# Estimation Methodologies for Machine Learning Classification Tasks

- **Simple split** (or holdout or test sample estimation)
  - Split the data into 2 mutually exclusive sets training (~70%) and testing (30%)

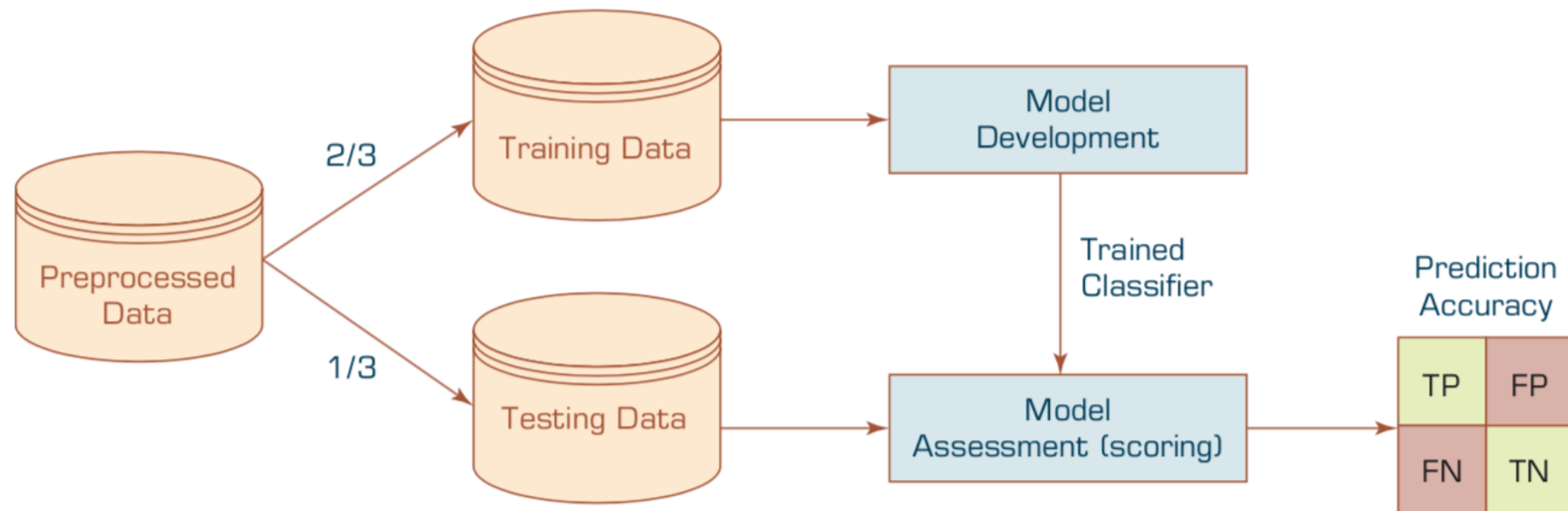

- For ANN, the data is split into three sub-sets (training [~60%], validation [~20%], testing [~20%])

# *k*-Fold Cross-Validation: Machine Learning Data Splitting and Model Assessment

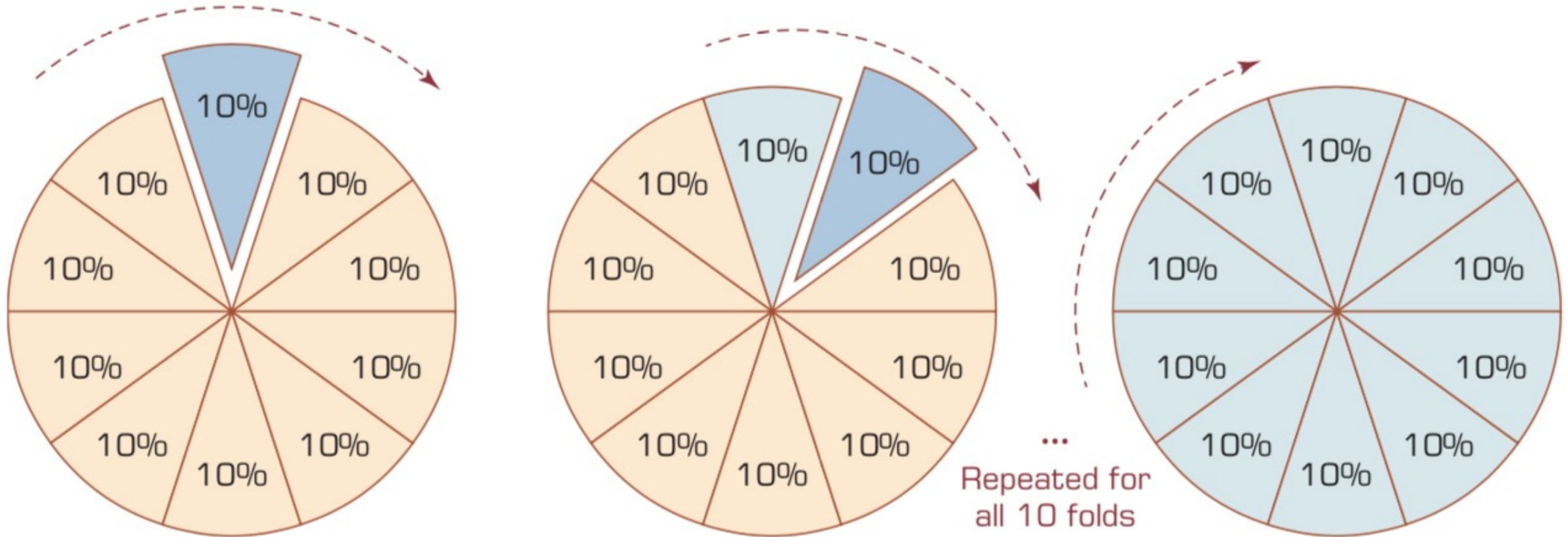

# Framework for Implementing Generative AI Services using RAG Model

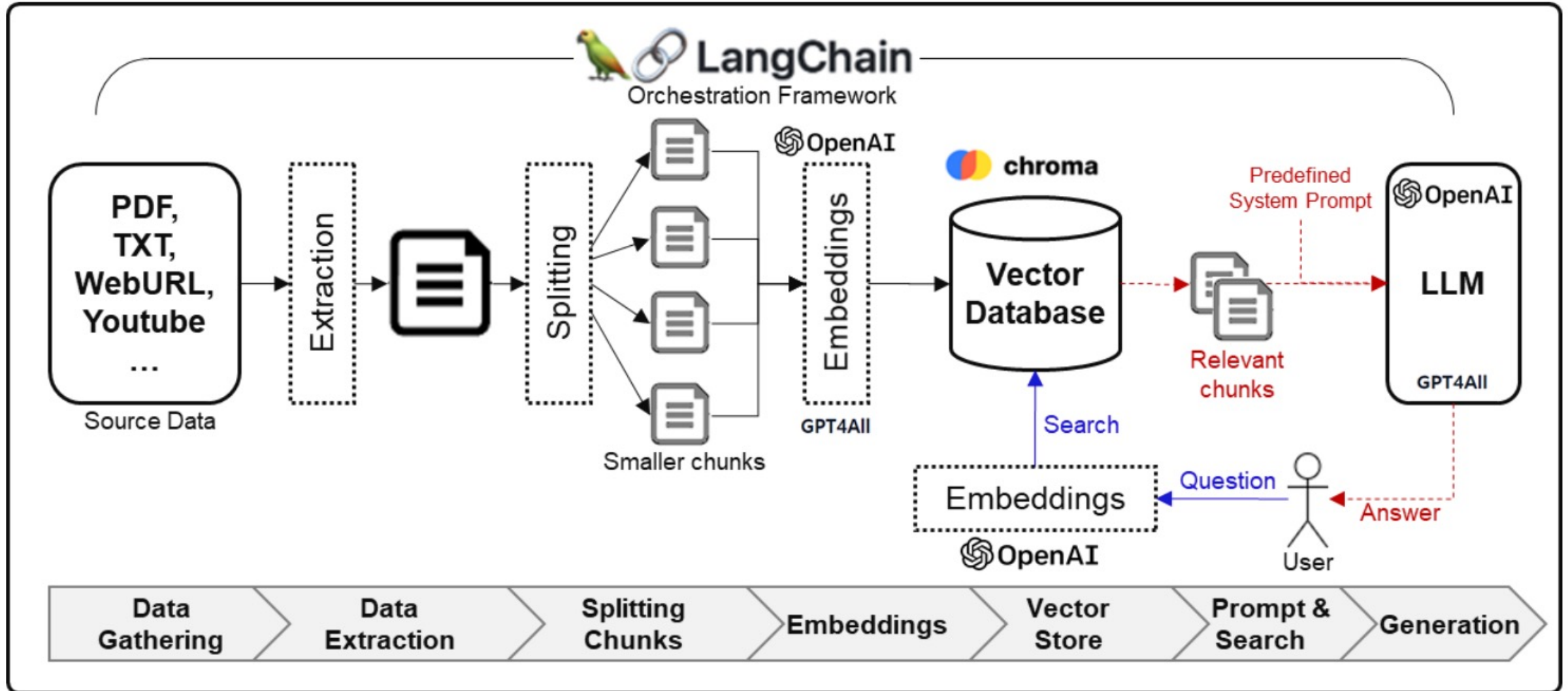

# Large Language Model (LLM) based Agents

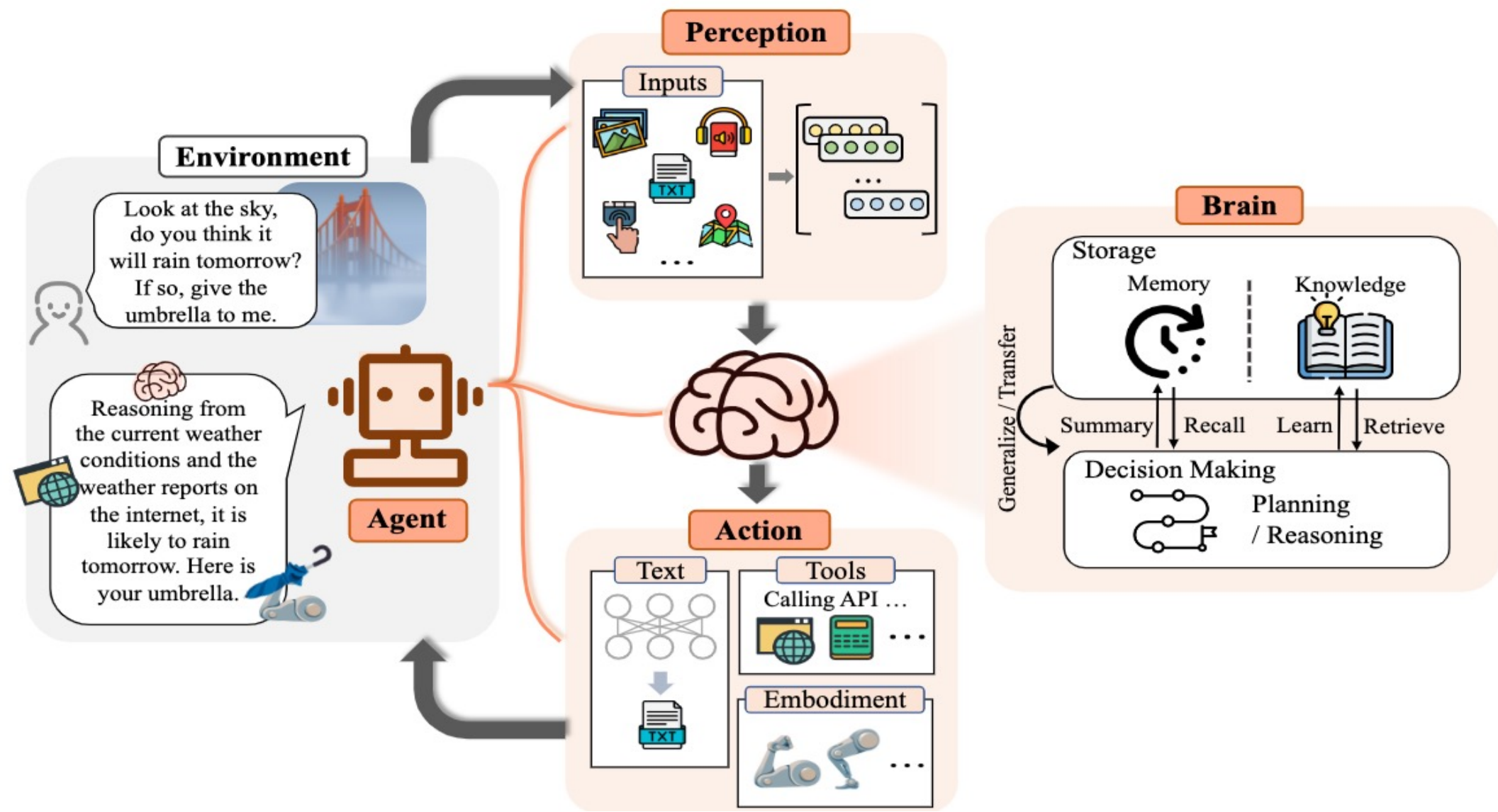

# LLM-based Agents

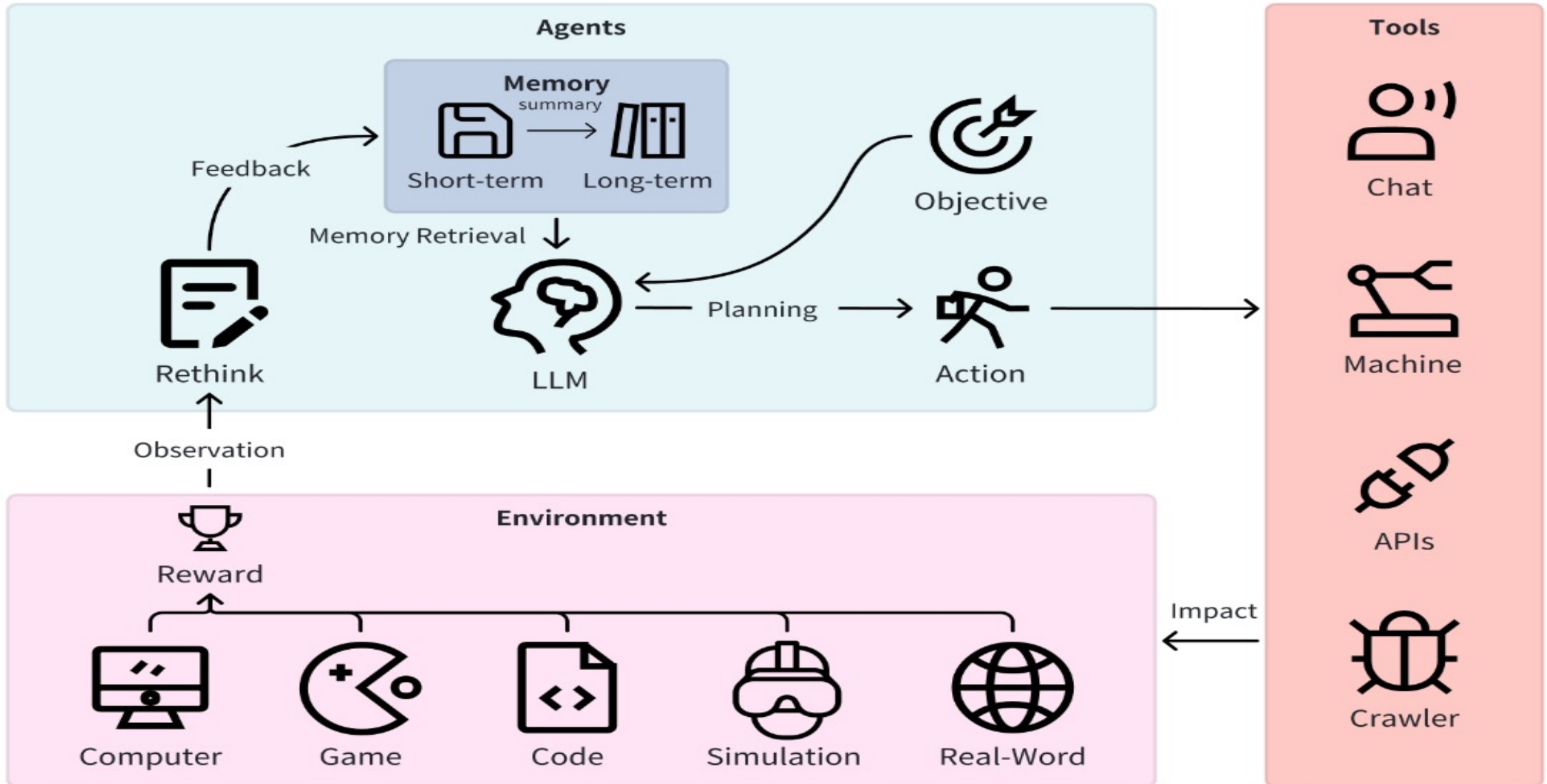

# Large Multimodal Agents (LMA)

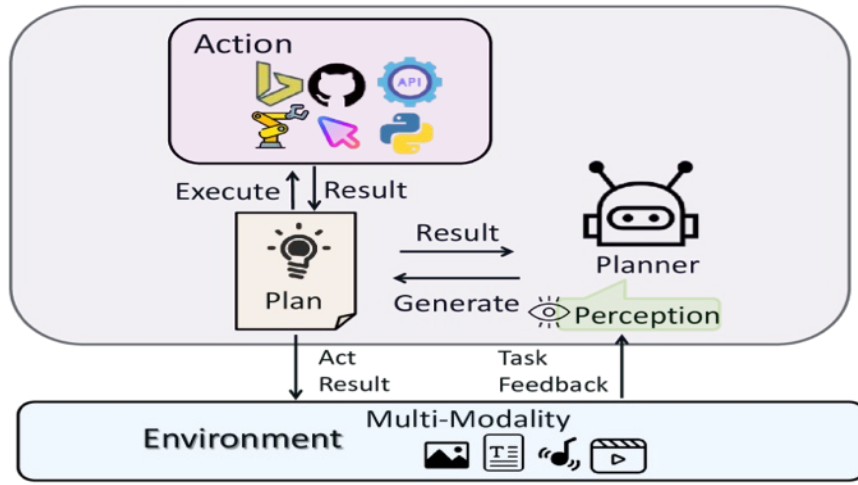

(a)

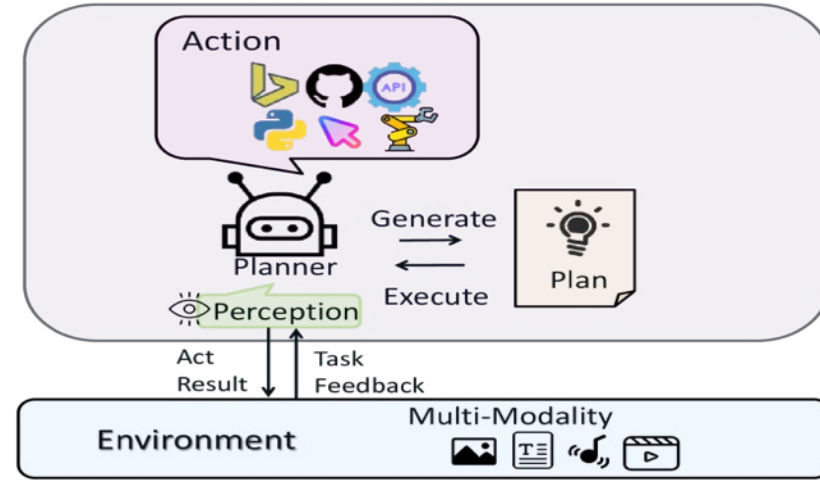

(b)

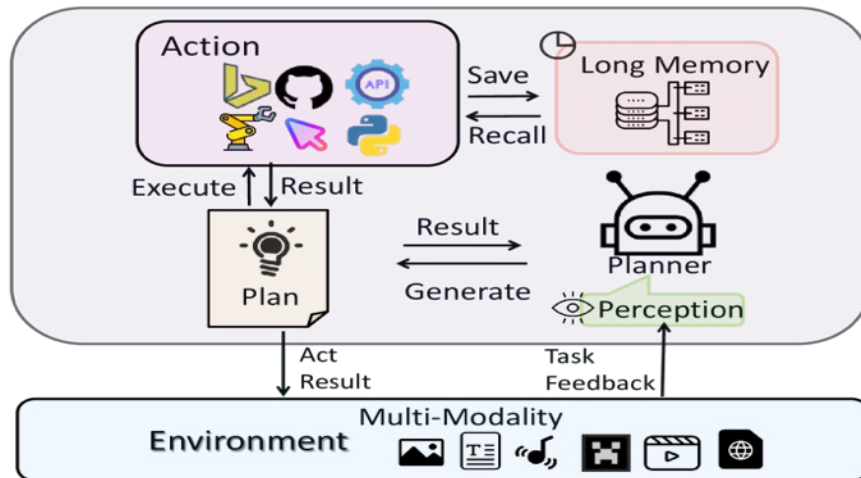

(c)

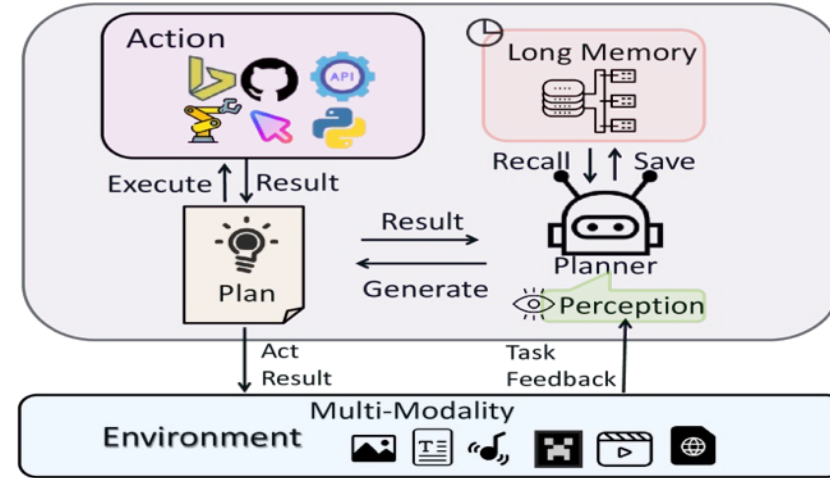

(d)

# Large Multimodal Agents (LMA)

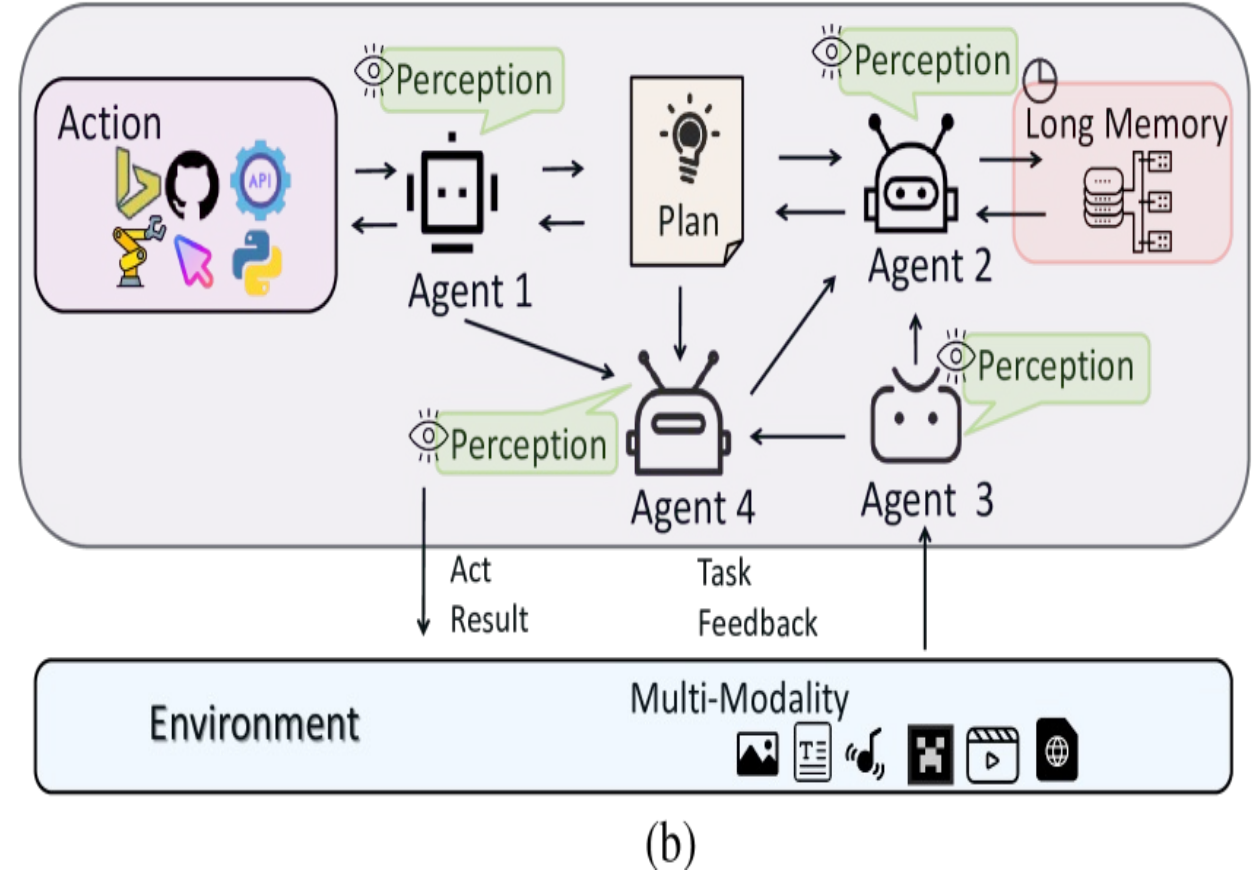
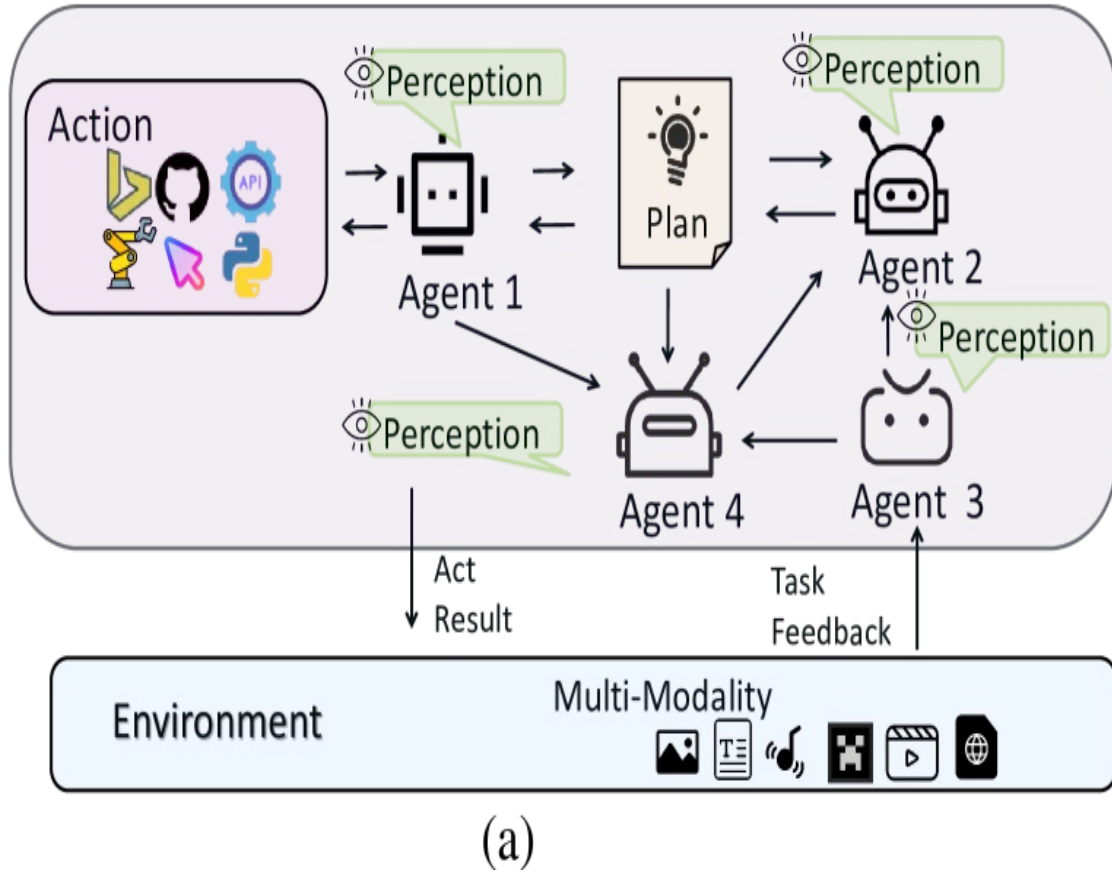

# Generative AI and LLMs for Sustainability and ESG Data Analytics





# Summary

- **Environmental, Social, and Governance (ESG)**
- **Net-Zero Digital Transformation**
  - **Net-Zero Transformation**
  - **Digital Transformation**

# References

- Cino Robin Castelli, Cyril Shmatov (2022), Quantitative Methods for ESG Finance, Wiley
- Simon Thompson (2023), Green and Sustainable Finance: Principles and Practice in Banking, Investment and Insurance, 2nd Edition, Kogan Page.
- Chrissa Pagitsas (2023), Chief Sustainability Officers At Work: How CSOs Build Successful Sustainability and ESG Strategies, Apress.
- Numa Dhamani and Maggie Engler (2024), Introduction to Generative AI, Manning.
- Denis Rothman (2024), Transformers for Natural Language Processing and Computer Vision - Third Edition: Explore Generative AI and Large Language Models with Hugging Face, ChatGPT, GPT-4V, and DALL-E 3, 3rd ed. Edition, Packt Publishing.
- Thomas R. Caldwell (2025), The Agentic AI Bible: The Complete and Up-to-Date Guide to Design, Build, and Scale Goal-Driven, LLM-Powered Agents that Think, Execute and Evolve, Independently published.
- GRI (Global Report Initiative):  
<https://www.globalreporting.org/>
- CDP (Carbon Disclosure Project):  
<https://www.cdp.net/>
- SASB (Sustainability Accounting Standards Board):  
<https://sasb.org/>
- ISSB (International Sustainability Standards Board):  
<https://www.ifrs.org/groups/international-sustainability-standards-board/>
- TCFD (Task Force on Climate-related Financial Disclosures):  
<https://www.fsb-tcf.org/>
- Min-Yuh Day (2025), Python 101, <https://tinyurl.com/aintpuython101>