

人工智慧文本分析 (AI for Text Analytics)

語意分析和命名實體識別 (Semantic Analysis and Named Entity Recognition; NER)

1091AITA09

MBA, IMTKU (M2455) (8418) (Fall 2020)

Thu 3, 4 (10:10-12:00) (B206)

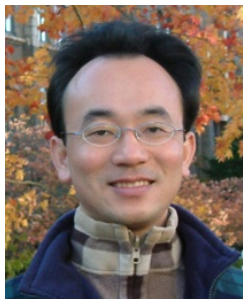

Min-Yuh Day

戴敏育

Associate Professor

副教授

Institute of Information Management, National Taipei University

國立臺北大學 資訊管理研究所

<https://web.ntpu.edu.tw/~myday>

2020-12-03



課程大綱 (Syllabus)

週次 (Week)	日期 (Date)	內容 (Subject/Topics)
1	2020/09/17	人工智慧文本分析課程介紹 (Course Orientation on Artificial Intelligence for Text Analytics)
2	2020/09/24	文本分析的基礎：自然語言處理 (Foundations of Text Analytics: Natural Language Processing; NLP)
3	2020/10/01	中秋節 (Mid-Autumn Festival) 放假一天 (Day off)
4	2020/10/08	Python自然語言處理 (Python for Natural Language Processing)
5	2020/10/15	處理和理解文本 (Processing and Understanding Text)
6	2020/10/22	文本表達特徵工程 (Feature Engineering for Text Representation)

課程大綱 (Syllabus)

週次 (Week)	日期 (Date)	內容 (Subject/Topics)
7	2020/10/29	人工智慧文本分析個案研究 I (Case Study on Artificial Intelligence for Text Analytics I)
8	2020/11/05	文本分類 (Text Classification)
9	2020/11/12	文本摘要和主題模型 (Text Summarization and Topic Models)
10	2020/11/19	期中報告 (Midterm Project Report)
11	2020/11/26	文本相似度和分群 (Text Similarity and Clustering)
12	2020/12/03	語意分析和命名實體識別 (Semantic Analysis and Named Entity Recognition; NER)

課程大綱 (Syllabus)

- | 週次 (Week) | 日期 (Date) | 內容 (Subject/Topics) |
|-----------|------------|--|
| 13 | 2020/12/10 | 情感分析
(Sentiment Analysis) |
| 14 | 2020/12/17 | 人工智慧文本分析個案研究 II
(Case Study on Artificial Intelligence for Text Analytics II) |
| 15 | 2020/12/24 | 深度學習和通用句子嵌入模型
(Deep Learning and Universal Sentence-Embedding Models) |
| 16 | 2020/12/31 | 問答系統與對話系統
(Question Answering and Dialogue Systems) |
| 17 | 2021/01/07 | 期末報告 I (Final Project Presentation I) |
| 18 | 2021/01/14 | 期末報告 II (Final Project Presentation II) |

Semantic Analysis and Named Entity Recognition (NER)

Outline

- Semantic Analysis
 - WordNet
 - Word sense disambiguation
- Named Entity Recognition (NER)

Semantic Analysis

- **Semantics**
 - the study of meaning
- **Linguistic semantics**
 - the study of meaning in natural language.

Semantic Analysis and NER

- WordNet and synsets
 - Analyzing lexical semantic relations
 - Word sense disambiguation
- Named entity recognition
- Analyzing semantic representations

WordNet

A Lexical Database for English

What is WordNet

People

News

Use Wordnet Online 

Download

Citing WordNet

License and Commercial Use

Related Projects

Documentation

Publications

Frequently Asked

What is WordNet?

Any opinions, findings, and conclusions or recommendations expressed in this material are those of the creators of WordNet and do not necessarily reflect the views of any funding agency or Princeton University.

When writing a paper or producing a software application, tool, or interface based on WordNet, it is necessary to properly **cite the source**. Citation figures are critical to WordNet funding.

About WordNet

WordNet® is a large lexical database of English. Nouns, verbs, adjectives and adverbs are grouped into sets of cognitive synonyms (synsets), each expressing a distinct concept. Synsets are interlinked by means of conceptual-semantic and lexical relations. The resulting network of meaningfully related words and concepts can be navigated with the **browser** . WordNet is also freely and publicly available for **download**. WordNet's structure makes it a useful tool for computational linguistics and natural language processing.

WordNet superficially resembles a thesaurus, in that it groups words together based on their

Note

Due to funding and staffing issues, we are no longer able to accept comment and suggestions.

We get numerous questions regarding topics that are addressed on our **FAQ** page. If you have a problem or question regarding something you downloaded from the "**Related projects**" page, you must contact the developer directly.

Please note that any changes

NLP

Classical NLP

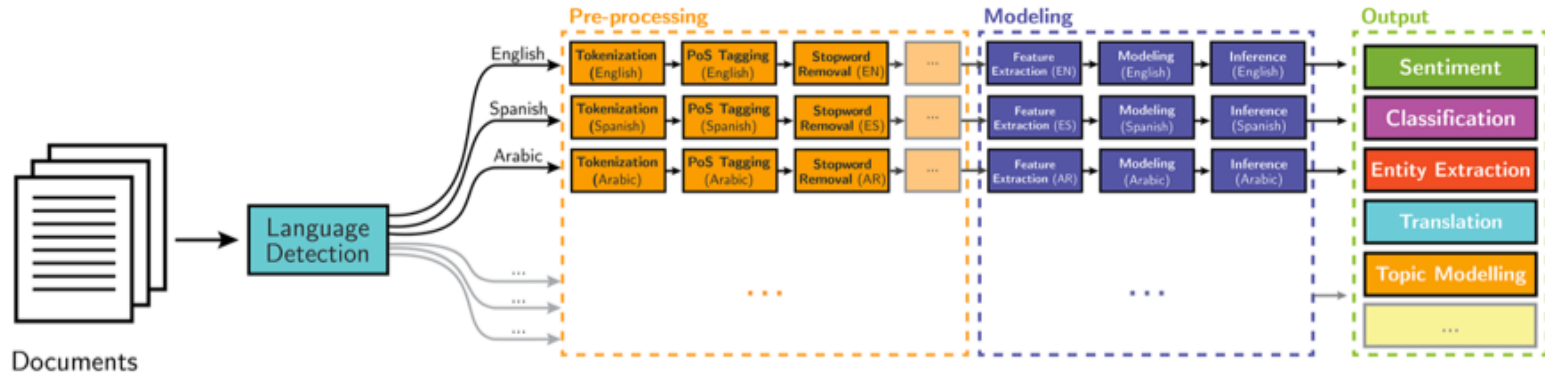

Deep Learning-based NLP

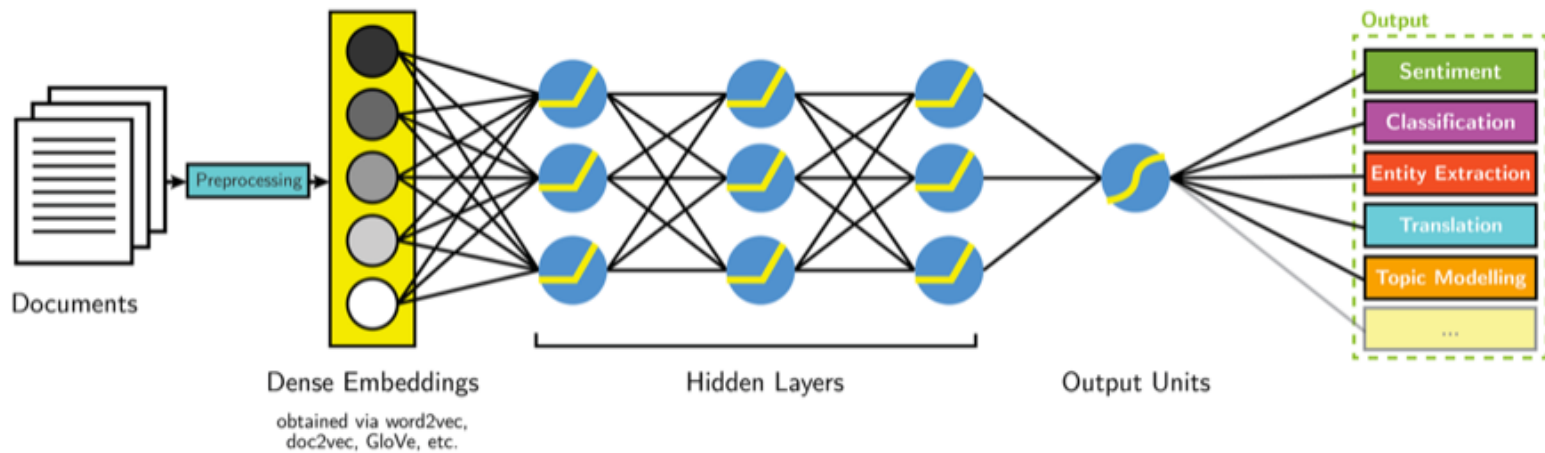

Modern NLP Pipeline

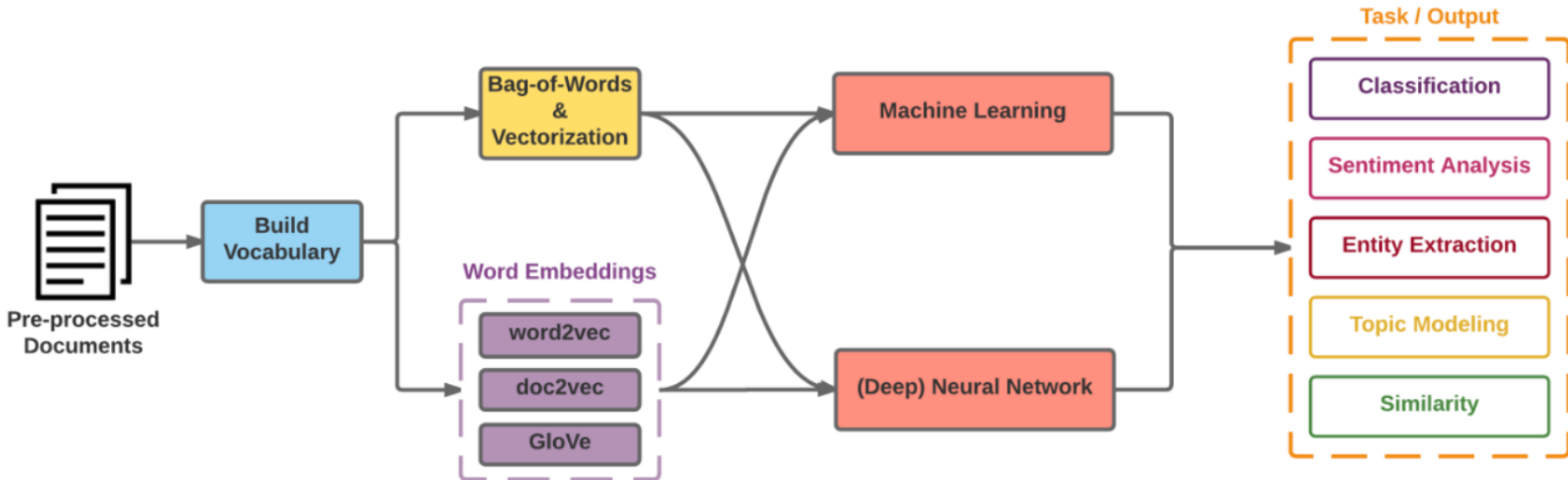
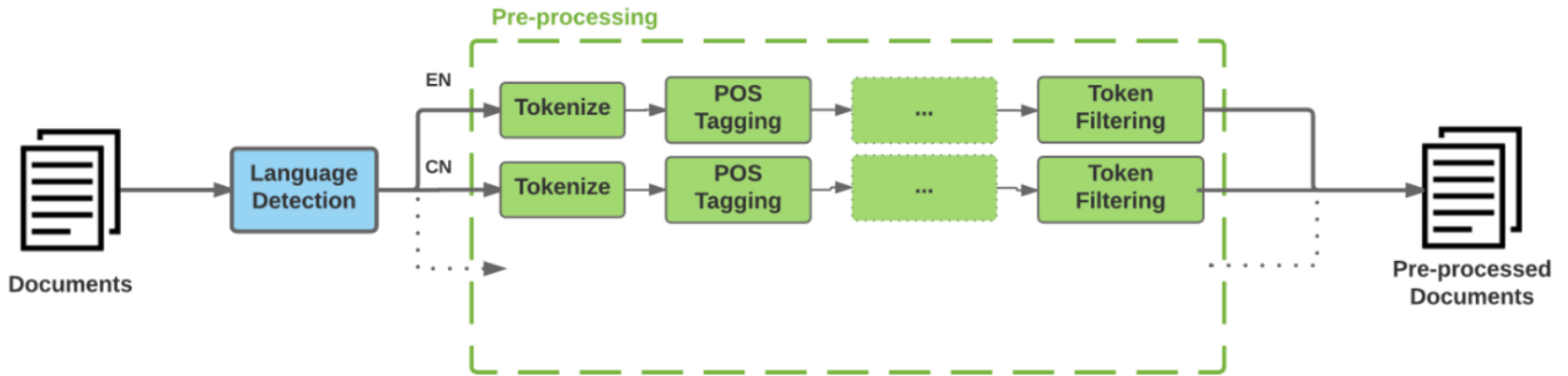

Modern NLP Pipeline

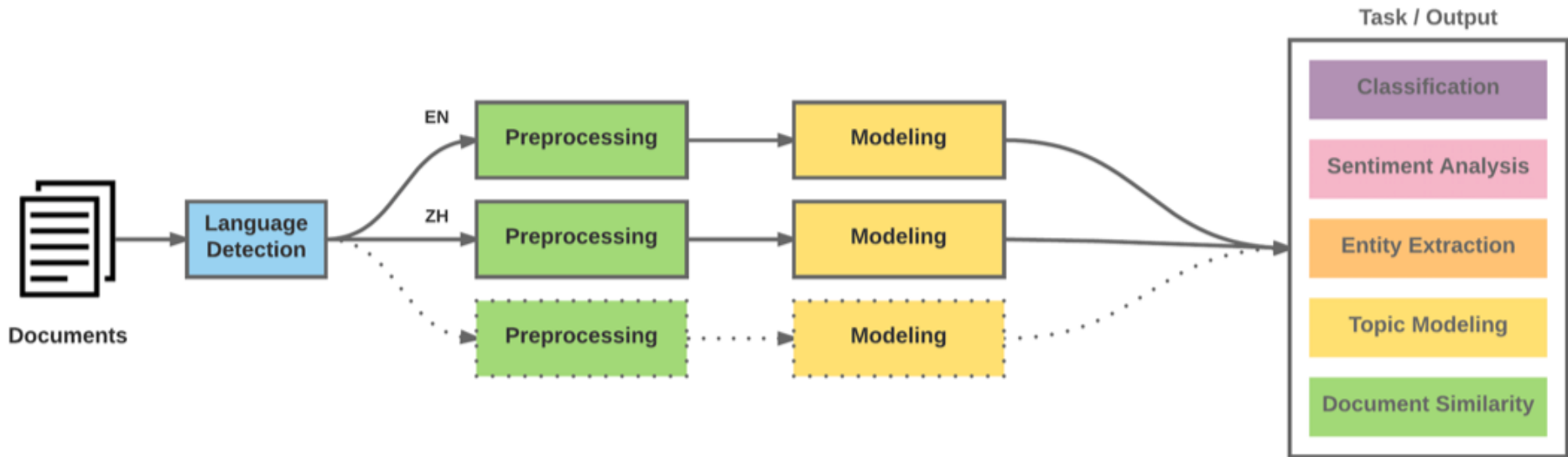

Deep Learning NLP

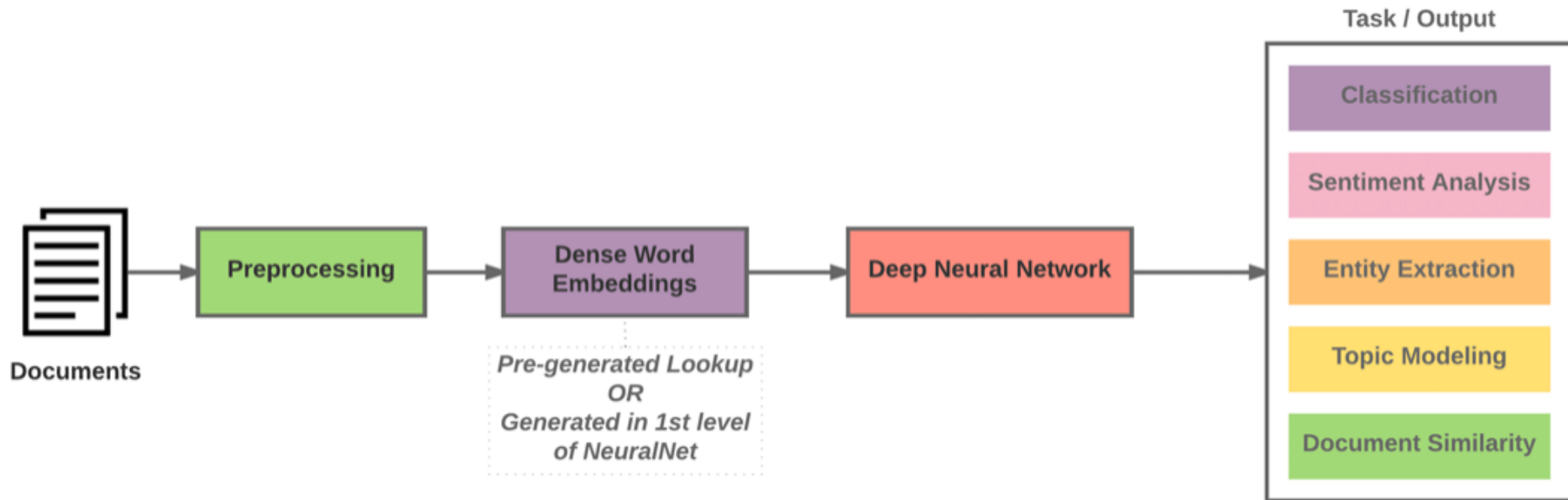

Natural Language Processing (NLP) and Text Mining

Raw text

Sentence Segmentation

Tokenization

Part-of-Speech (POS)

Stop word removal

Stemming / Lemmatization

Dependency Parser

String Metrics & Matching

word's stem

am → am

having → hav

word's lemma

am → be

having → have

Analyzing Lexical Semantic Relationships

- Entailments
- Homonyms and Homographs
- Synonyms and Antonyms
- Hyponyms and Hypernyms
- Holonyms and Meronyms
- Semantic Relationships and Similarity

Word Sense Disambiguation

- Lesk algorithm (Lesk, 1986)
 - leverage dictionary or **vocabulary definitions** for a word we want to disambiguate in a body of text and compare the words in these **definitions** with a section of text surrounding our word of interest.
 - The main objective is to return the **synset** with the maximum number of overlapping words or terms between the context sentence and the **different definitions from each synset** for the word we target for **disambiguation**.

Named Entity Recognition (NER)

- **Named entities**
 - represent real-world objects
 - people, places, organizations
 - proper names
- **Named entity recognition**
 - Entity chunking
 - Entity extraction

NER: OntoNotes 5 Named Entities

SID	TYPE	DESCRIPTION
1	PERSON	People, including fictional.
2	NORP	Nationalities or religious or political groups.
3	FAC	Buildings, airports, highways, bridges, etc.
4	ORG	Companies, agencies, institutions, etc.
5	GPE	Countries, cities, states.
6	LOC	Non-GPE locations, mountain ranges, bodies of water.
7	PRODUCT	Objects, vehicles, foods, etc. (Not services.)
8	EVENT	Named hurricanes, battles, wars, sports events, etc.
9	WORK_OF_ART	Titles of books, songs, etc.
10	LAW	Named documents made into laws.
11	LANGUAGE	Any named language.
12	DATE	Absolute or relative dates or periods.
13	TIME	Times smaller than a day.
14	PERCENT	Percentage, including "%".
15	MONEY	Monetary values, including unit.
16	QUANTITY	Measurements, as of weight or distance.
17	ORDINAL	"first", "second", etc.
18	CARDINAL	Numerals that do not fall under another type.

Source: <https://spacy.io/api/annotation#named-entities>

NER: Wikipedia Named Entities

SID	TYPE	DESCRIPTION
1	PER	Named person or family.
2	LOC	Name of politically or geographically defined location (cities, provinces, countries, international regions, bodies of water, mountains).
3	ORG	Named corporate, governmental, or other organizational entity.
4	MISC	Miscellaneous entities, e.g. events, nationalities, products or works of art.

NER IOB Scheme

TAG	ID	DESCRIPTION
"I"	1	Token is inside an entity.
"O"	2	Token is outside an entity.
"B"	3	Token begins an entity.
""	0	No entity tag is set (missing value).

NER **BILUO** Scheme

TAG	DESCRIPTION
BEGIN	The first token of a multi-token entity.
IN	An inner token of a multi-token entity.
LAST	The final token of a multi-token entity.
UNIT	A single-token entity.
OUT	A non-entity token.

BERT Sequence-level tasks

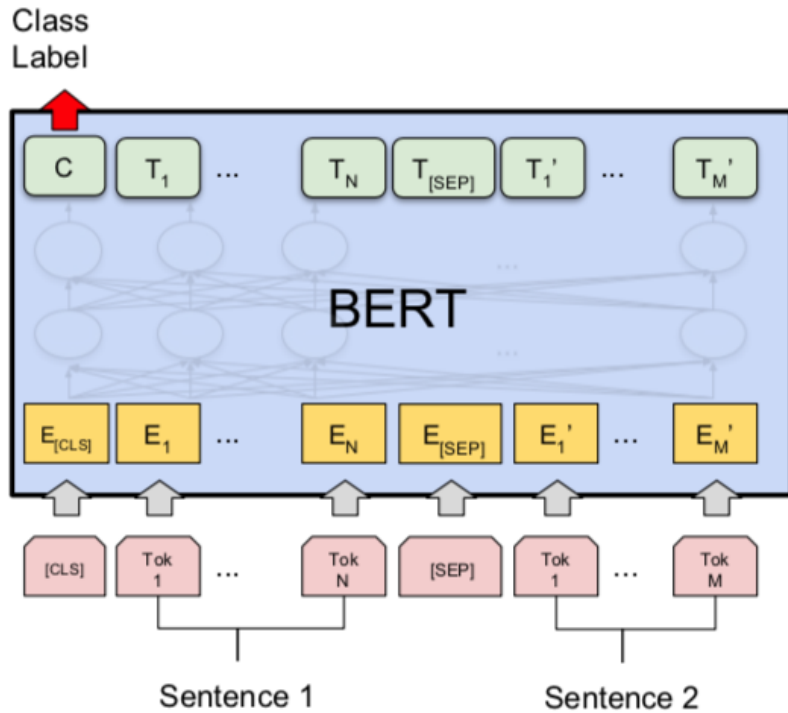

(a) Sentence Pair Classification Tasks:
MNLI, QQP, QNLI, STS-B, MRPC,
RTE, SWAG

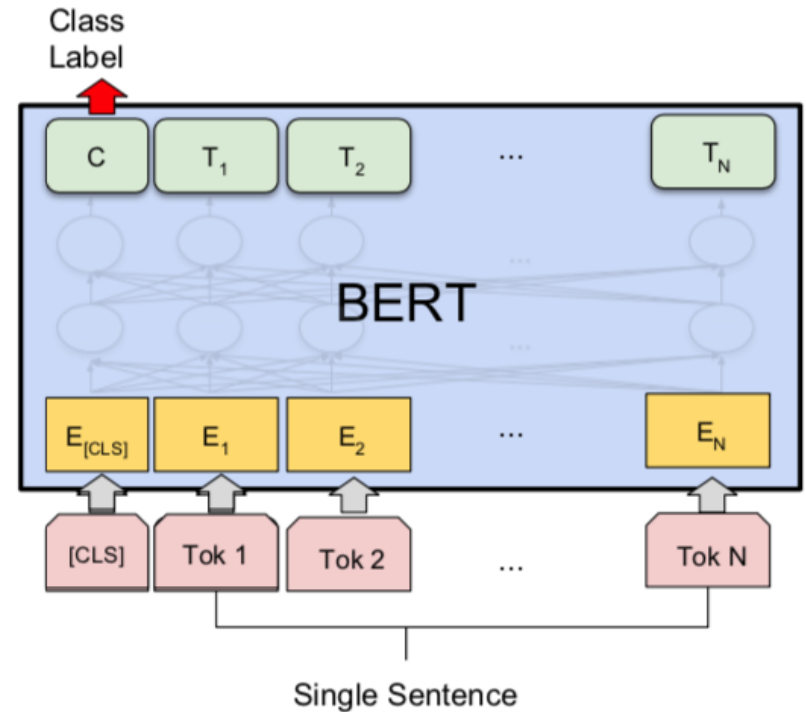

(b) Single Sentence Classification Tasks:
SST-2, CoLA

BERT Token-level tasks

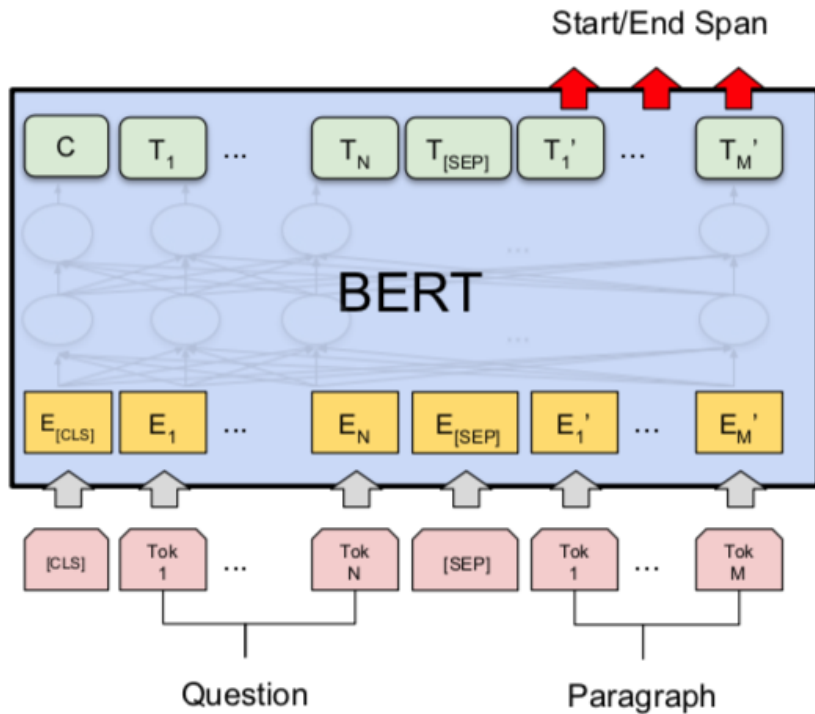

(c) Question Answering Tasks:
SQuAD v1.1

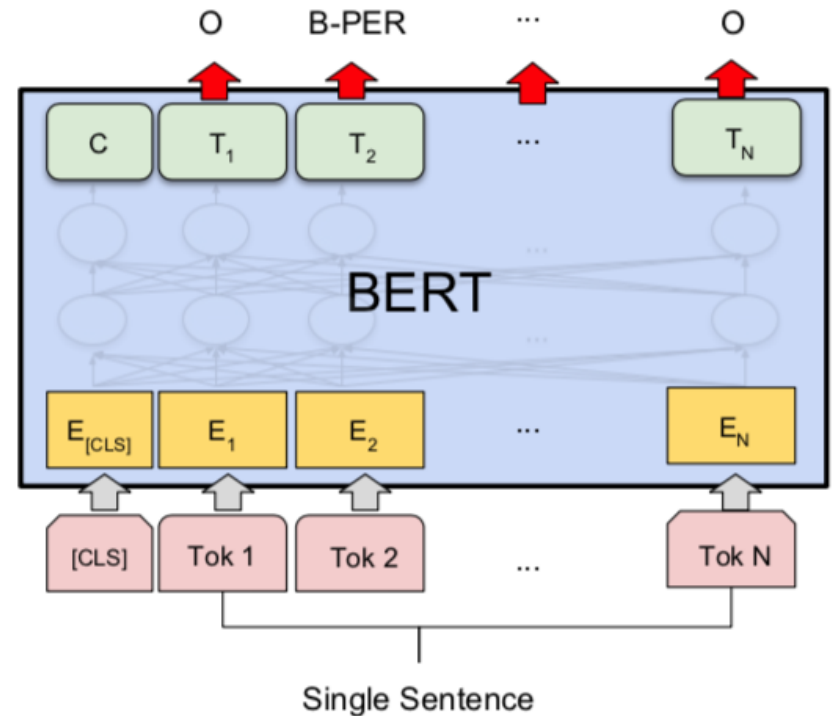

(d) Single Sentence Tagging Tasks:
CoNLL-2003 NER

NER: Single Sentence Tagging

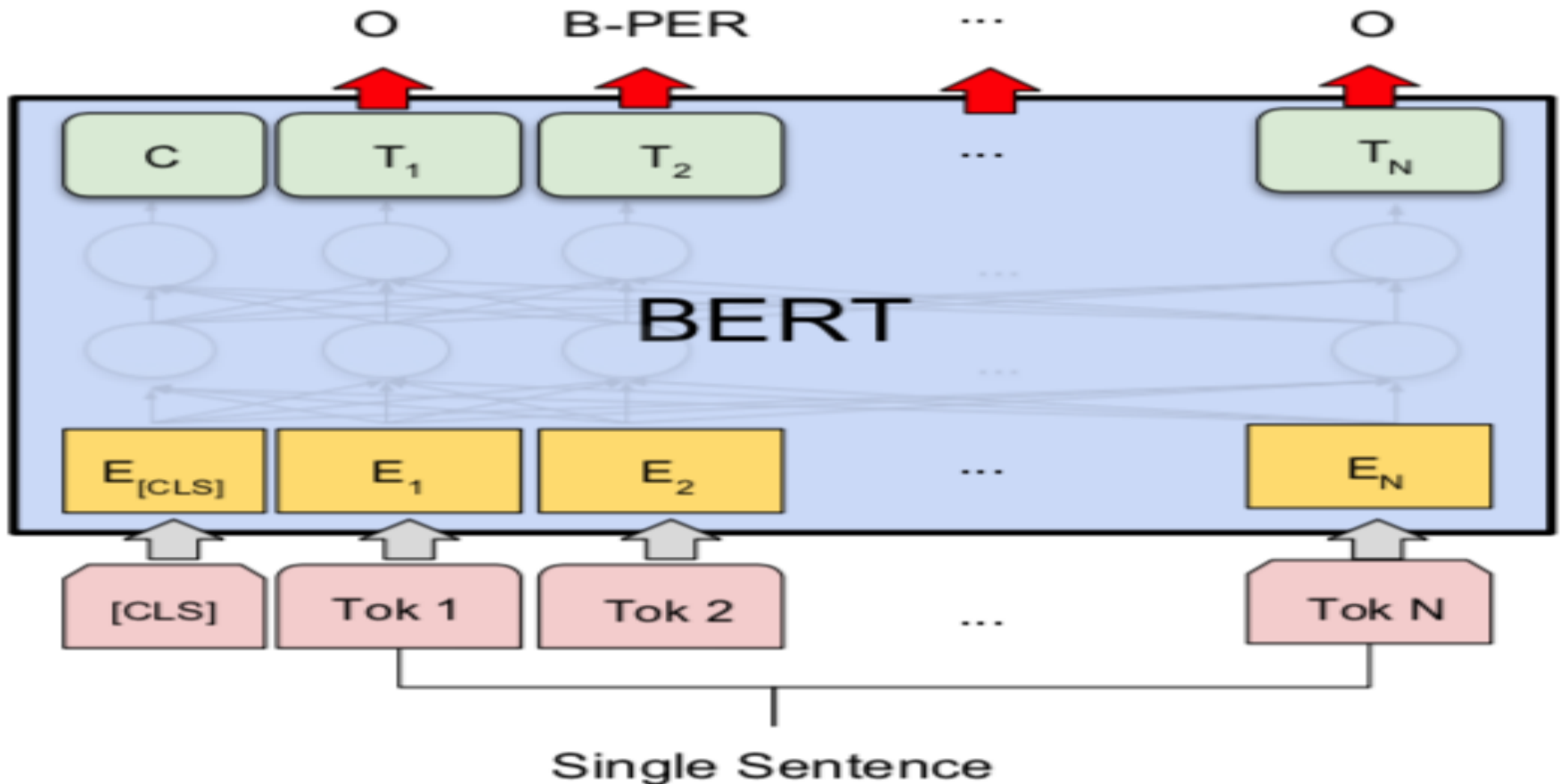

(d) Single Sentence Tagging Tasks:
CoNLL-2003 NER

Source: Devlin, Jacob, Ming-Wei Chang, Kenton Lee, and Kristina Toutanova (2018).

"BERT: Pre-training of Deep Bidirectional Transformers for Language Understanding." arXiv preprint arXiv:1810.04805

NER: Fine-tuning BERT with Bi-LSTM CRF

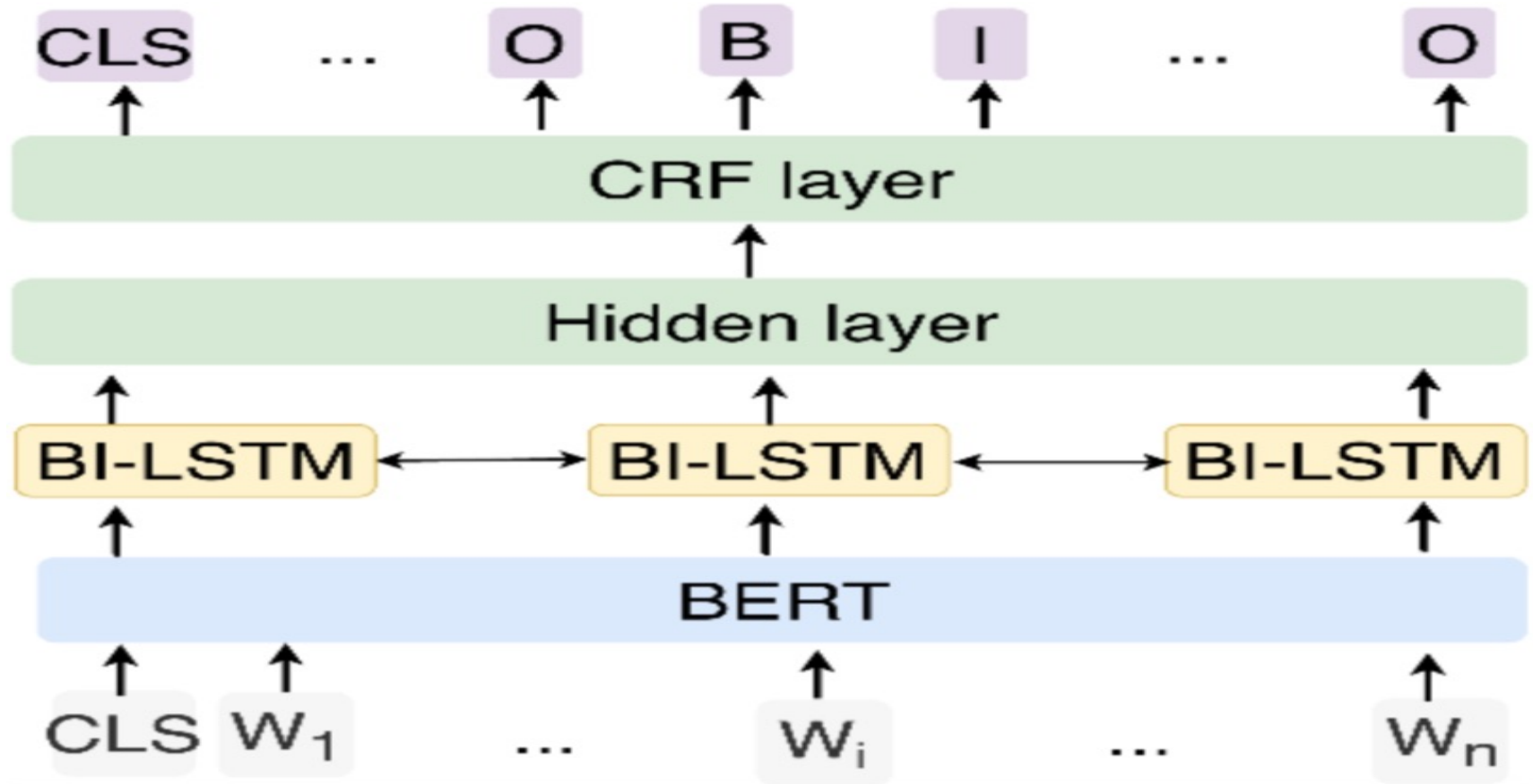

Python in Google Colab (Python101)

<https://colab.research.google.com/drive/1FEG6DnGvwfUbeo4zJ1zTunjMqf2RkCrT>

python101.ipynb ☆

File Edit View Insert Runtime Tools Help All changes saved

Comment Share

RAM Disk Editing

Table of contents

- Text Classification: BBC News Articles
- Text Summarization and Topic Modeling
- Text Summarization
 - Text Summarization with Gensim
 - Text Summarization
- Topic Modeling
 - Topic Modeling with Gensim LSI model
 - Topic Modeling with Gensim LDA model
 - Topic Modeling with Scikit-learn LDA and NMF
 - Topic Modeling Visualization
- Text Similarity and Clustering
 - Text Similarity
 - Text Clustering
- Semantic Analysis and Named Entity Recognition (NER)**
 - Semantic Analysis
 - Named Entity Recognition (NER)

Semantic Analysis and Named Entity Recognition (NER)

- Source: Dipanjan Sarkar (2019), Text Analytics with Python: A Practitioner's Guide to Natural Language Processing, Second Edition. APress. <https://github.com/Apress/text-analytics-w-python-2e>

Semantic Analysis

```
[1] 1 import nltk
    2 from nltk.corpus import wordnet as wn
    3 import pandas as pd
    4 nltk.download('wordnet')
    5 # WordNet Synsets
    6 word = 'fruit'
    7 synsets = wn.synsets(word)
    8 print('Word:', word)
    9 print('Wordnet Synsets:', len(synsets))
   10 df = pd.DataFrame([{'Synset': synset,
   11                    'Part of Speech': synset.lexname(),
   12                    'Definition': synset.definition(),
   13                    'Lemmas': synset.lemma_names(),
   14                    'Examples': synset.examples()}
   15                    for synset in synsets])
   16 df
```

[nltk_data] Downloading package wordnet to /root/nltk_data...
[nltk_data] Unzipping corpora/wordnet.zip.
Word: fruit
Wordnet Synsets: 5

	Synset	Part of Speech	Definition	Lemmas	Examples
0	Synset('fruit.n.01')	noun.plant	the ripened reproductive body of a seed plant	[fruit]	[]
1	Synset('yield.n.03')	noun.artifact	an amount of a product	[yield, fruit]	[]

<https://tinyurl.com/aintpuppython101>

Python in Google Colab (Python101)

<https://colab.research.google.com/drive/1FEG6DnGvwfUbeo4zJ1zTunjMqf2RkCrT>

python101.ipynb ☆

File Edit View Insert Runtime Tools Help [All changes saved](#)

Comment Share

RAM Disk Editing

Table of contents

- Text Classification: BBC News Articles
- Text Summarization and Topic Modeling
 - Text Summarization
 - Text Summarization with Gensim
 - Text Summarization
 - Topic Modeling
 - Topic Modeling with Gensim LSI model
 - Topic Modeling with Gensim LDA model
 - Topic Modeling with Scikit-learn LDA and NMF
 - Topic Modeling Visualization
- Text Similarity and Clustering
 - Text Similarity
 - Text Clustering
- Semantic Analysis and Named Entity Recognition (NER)
 - Semantic Analysis
 - Named Entity Recognition (NER)**

```
November with the intention of hearing from Zuckerberg. Since the Cambridge Analytica scandal broke, the Facebook chief has only appeared in front of two legislatures: the American Senate and House of Representatives, and the European parliament. Facebook has consistently rebuffed attempts from others, including the UK and Canadian parliaments, to hear from Zuckerberg. He added that an article in the New York Times on Thursday, in which the paper alleged a pattern of behaviour from Facebook to "delay, deny and deflect" negative news stories, "raises further questions about how recent data breaches were allegedly dealt with within Facebook."
```

```
re.sub: Three more countries have joined an "international grand committee" of parliaments, adding to calls for Facebook's boss, Mark Zuckerberg.
text_nlp: Three more countries have joined an "international grand committee" of parliaments, adding to calls for Facebook's boss, Mark Zuckerberg.
```

```
[ ] 1 # print named entities in article
    2 ner_tagged = [(word.text, word.ent_type_) for word in text_nlp]
    3 print(ner_tagged)
```

```
[ ] 1 from spacy import displacy
    2 # visualize named entities
    3 displacy.render(text_nlp, style='ent', jupyter=True)
```

Three **CARDINAL** more countries have joined an "international grand committee" of parliaments, adding to calls for Facebook's boss, **Mark Zuckerberg PERSON**, to give evidence on misinformation to the coalition. **Brazil GPE**, **Latvia GPE** and **Singapore GPE** bring the total to **eight CARDINAL** different parliaments across the world, with plans to send representatives to **London GPE** on **27 November DATE** with the intention of hearing from **Zuckerberg GPE**. Since the Cambridge Analytica scandal broke, the **Facebook ORG** chief has only appeared in front of **two CARDINAL** legislatures: **the American Senate ORG** and **House of Representatives ORG**, and the **European NORP** parliament. Facebook has consistently rebuffed attempts from others, including the **UK GPE** and **Canadian NORP** parliaments, to hear from **Zuckerberg GPE**. He added that an article in **the New York Times ORG** on **Thursday DATE**, in which the paper alleged a pattern of behaviour from **Facebook ORG** to "delay, deny and deflect" negative news stories, "raises further questions about how recent data breaches were allegedly dealt with within **Facebook ORG**."

<https://tinyurl.com/aintpuython101>

NLP Benchmark Datasets

Task	Dataset	Link
Machine Translation	WMT 2014 EN-DE WMT 2014 EN-FR	http://www-lium.univ-lemans.fr/~schwenk/csmlm_joint_paper/
Text Summarization	CNN/DM Newsroom DUC Gigaword	https://cs.nyu.edu/~kcho/DMQA/ https://summari.es/ https://www-nlpir.nist.gov/projects/duc/data.html https://catalog.ldc.upenn.edu/LDC2012T21
Reading Comprehension Question Answering Question Generation	ARC CliCR CNN/DM NewsQA RACE SQuAD Story Cloze Test NarrativeQA Quasar SearchQA	http://data.allenai.org/arc/ http://aclweb.org/anthology/N18-1140 https://cs.nyu.edu/~kcho/DMQA/ https://datasets.maluuba.com/NewsQA http://www.qizhexie.com/data/RACE_leaderboard https://rajpurkar.github.io/SQuAD-explorer/ http://aclweb.org/anthology/W17-0906.pdf https://github.com/deepmind/narrativeqa https://github.com/bdhingra/quasar https://github.com/nyu-dl/SearchQA
Semantic Parsing	AMR parsing ATIS (SQL Parsing) WikiSQL (SQL Parsing)	https://amr.isi.edu/index.html https://github.com/jkkummerfeld/text2sql-data/tree/master/data https://github.com/salesforce/WikiSQL
Sentiment Analysis	IMDB Reviews SST Yelp Reviews Subjectivity Dataset	http://ai.stanford.edu/~amaas/data/sentiment/ https://nlp.stanford.edu/sentiment/index.html https://www.yelp.com/dataset/challenge http://www.cs.cornell.edu/people/pabo/movie-review-data/
Text Classification	AG News DBpedia TREC 20 NewsGroup	http://www.di.unipi.it/~gulli/AG_corpus_of_news_articles.html https://wiki.dbpedia.org/Datasets https://trec.nist.gov/data.html http://qwone.com/~jason/20Newsgroups/
Natural Language Inference	SNLI Corpus MultiNLI SciTail	https://nlp.stanford.edu/projects/snli/ https://www.nyu.edu/projects/bowman/multinli/ http://data.allenai.org/scitail/
Semantic Role Labeling	Proposition Bank OneNotes	http://propbank.github.io/ https://catalog.ldc.upenn.edu/LDC2013T19

Summary

- Semantic Analysis
 - WordNet
 - Word sense disambiguation
- Named Entity Recognition (NER)

References

- Dipanjan Sarkar (2019), Text Analytics with Python: A Practitioner's Guide to Natural Language Processing, Second Edition. APress. <https://github.com/Apress/text-analytics-w-python-2e>
- Benjamin Bengfort, Rebecca Bilbro, and Tony Ojeda (2018), Applied Text Analysis with Python, O'Reilly Media. <https://www.oreilly.com/library/view/applied-text-analysis/9781491963036/>
- HuggingFace (2020), Transformers Notebook, <https://huggingface.co/transformers/notebooks.html>
- The Super Duper NLP Repo, <https://notebooks.quantumstat.com/>
- Min-Yuh Day (2020), Python 101, <https://tinyurl.com/aintpuython101>